

FOLDING DOOR: ASSEMBLY INSTRUCTION

SERIES 1200

Version 1.0 (2016-11-30)

3.03.1.c

Assembly  easy medium difficult

Subject to technical changes.

raumplus

CONTENT AND TOOLS

CONTENT:

Content and tools	page	02
Product information	page	03
Accessories	page	05
Exploded drawing	page	06
Cutting dimensions	page	07
Detail drawings	page	08
Assembly instruction	page	10



The working steps described in this instruction are exclusively valid for the folding door »DIN left«. The assembly for the folding door »DIN right« is to be carried out mirror-inverted – with special attention to page 9.

TOOLS:

(without claim of completeness)

- (Percussion) drilling machine
- Steel drill set
- Cordless screwdriver
- Aluminium saw
- Allen key set
- Water level
- Rubber mallet
- Straight edge



Version 1.0:











VERSION INFORMATION:

PRODUCT INFORMATION

GENERAL INFORMATION: Preparation

- This manual is part of the product and describes the safe and proper installation of the system. Please read the instructions carefully before installation
- Please note that the assembly should only be done by qualified and trained staff in strict compliance with all details indicated in this document. Improper installation in variation from manufacturer's specification may cause defects and danger, thus endangering the safe fixing of the product as well as the safety of the prospective user. The liability of the manufacturer shall be excluded in case of defects and consequential damages resulting from incorrect assembly of this product.
- Please check the completeness of the delivered parts and check carefully if any transport damages are visible.
- If any parts are damaged or lost, please immediately contact the responsible supplier.
- It is assumed that you have exactly identified all cutting dimensions according to the measurement instruction for **raumplus** products.

SYMBOLE:

Symbol	Importance	Symbol	Importance
	Risk or danger!		During the installation do not use a striking tool
	Advice and information		No leverage tool for disassembly of fittings
	Additional information / other documents		Be aware of the risk of entrapment.
	Directional data / direction of movement		
	„yes“ and „right“		
	„no“ and „wrong“		
	Follow the order		

SYSTEM:

System Information: System 42 Serie1200

- max. weight of element = **30 kg**
- min./max. door height = **700 mm / 2750 mm**
- min./max. door width = **350 mm / 750 mm**

PRODUCT INFORMATION

GENERAL INFORMATION: **Product safety**

- The System complies with the prior of the art and the authorized safety rules at the time of delivery.

USE:

Intended use

- The prerequisite for the intended use of our products is the professional installation according to our installation instruction. Sufficient fittings must be available and durably installed to all relevant places. The function of the fittings must not be hindered or altered during installation.
- Special solutions are only possible in consultation with **raumplus**.

Incorrect use

- Risk or danger may occur in the following cases:
 - the door system has improperly been installed or maintained
 - the safety and installation instructions have not been followed.
 - after improper installation or inadequate fixing (e.g. to parts of buildings)
 - the maximum weight of the doors has been exceeded.
 - improper shock and case loads or other additional loads on the fittings have occurred
 - the fittings have been used outside.
 - body parts or objects got into the closing edges or door runnings during use of the door wing.
 - the door system is not used as intended.

Structural modifications

- Structural modifications that are not offered as an accessory from **raumplus** may only be attached or installed with permission of **raumplus GmbH!**

ACCESSORIES

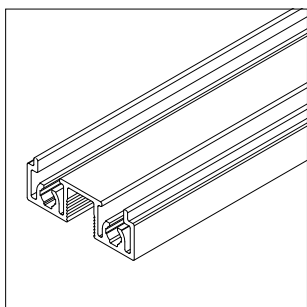

1_ 12.46.0xx

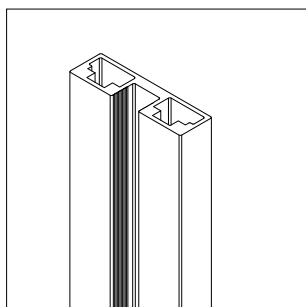

2_ 12.01.0xx

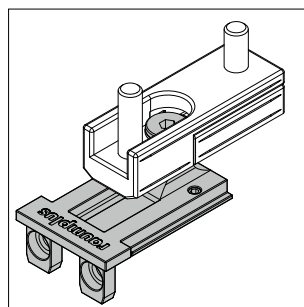

3_ 10.02.420

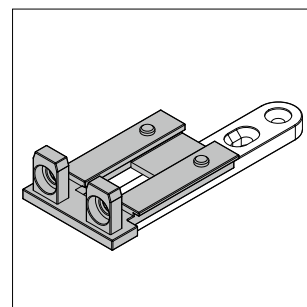

4_ 10.02.450

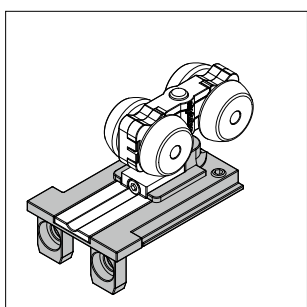

5_ 10.02.410

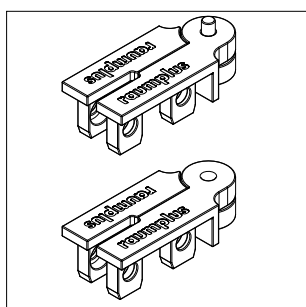

6_ 10.02.430

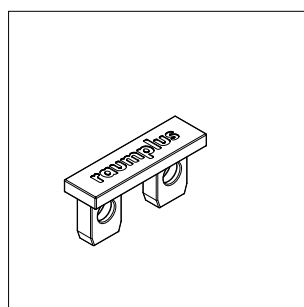

7_ 10.02.460

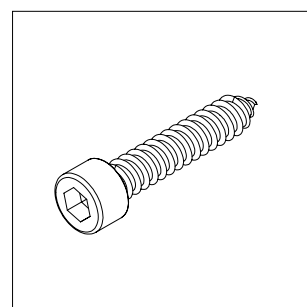

8_ 10.07.012

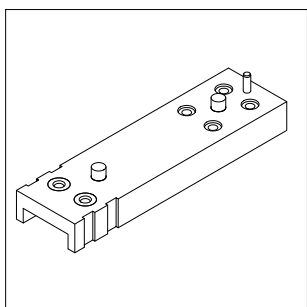

9_ 30.14.018

1_ Rail folding-/hinge door S1200

2_ Stile S1200

3_ Pick up element set for folding-/hinge door S1200

4_ Mounting plate set for folding-/hinge door S1200

5_ Top roller incl. pick up element, folding door S120

6_ Folding door hinge set S1200

7_ Frame connector for folding-/hinge door S1200

8_ Frame screws 6,3 x 32mm stainless steel

white head

black oxidized

silver mat

10.07.212

10.07.213

10.07.214

9_ Drilling template for S1200

without illustration:

10_ Countersink set w. guiding pin S1200

30.14.020

11_ Panel

EXPLODED DRAWING

DIN LEFT

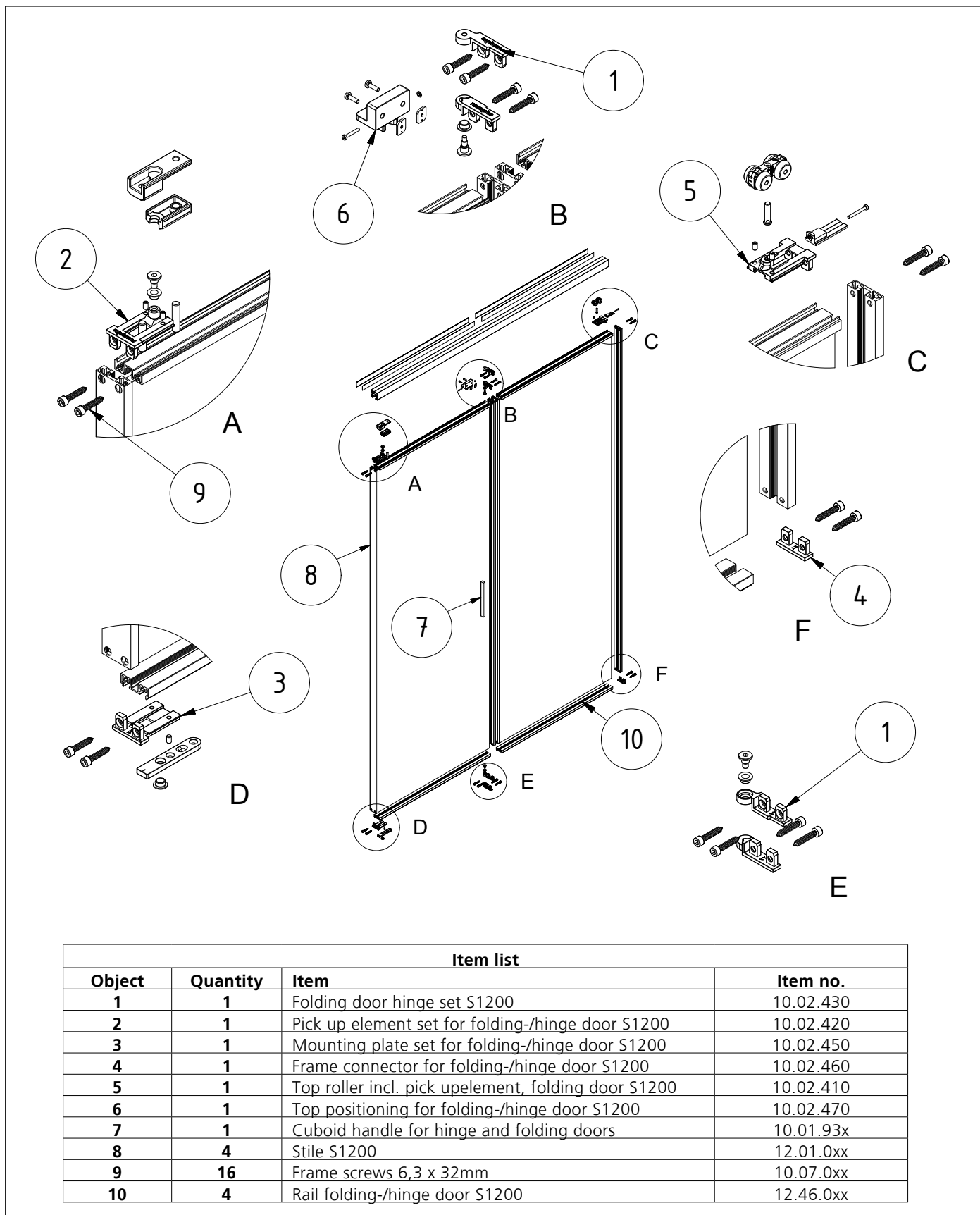

1_ Complete folding door **DIN Left**

DETAIL DRAWING

PREPARING STILES / CUTTING DIMENSIONS

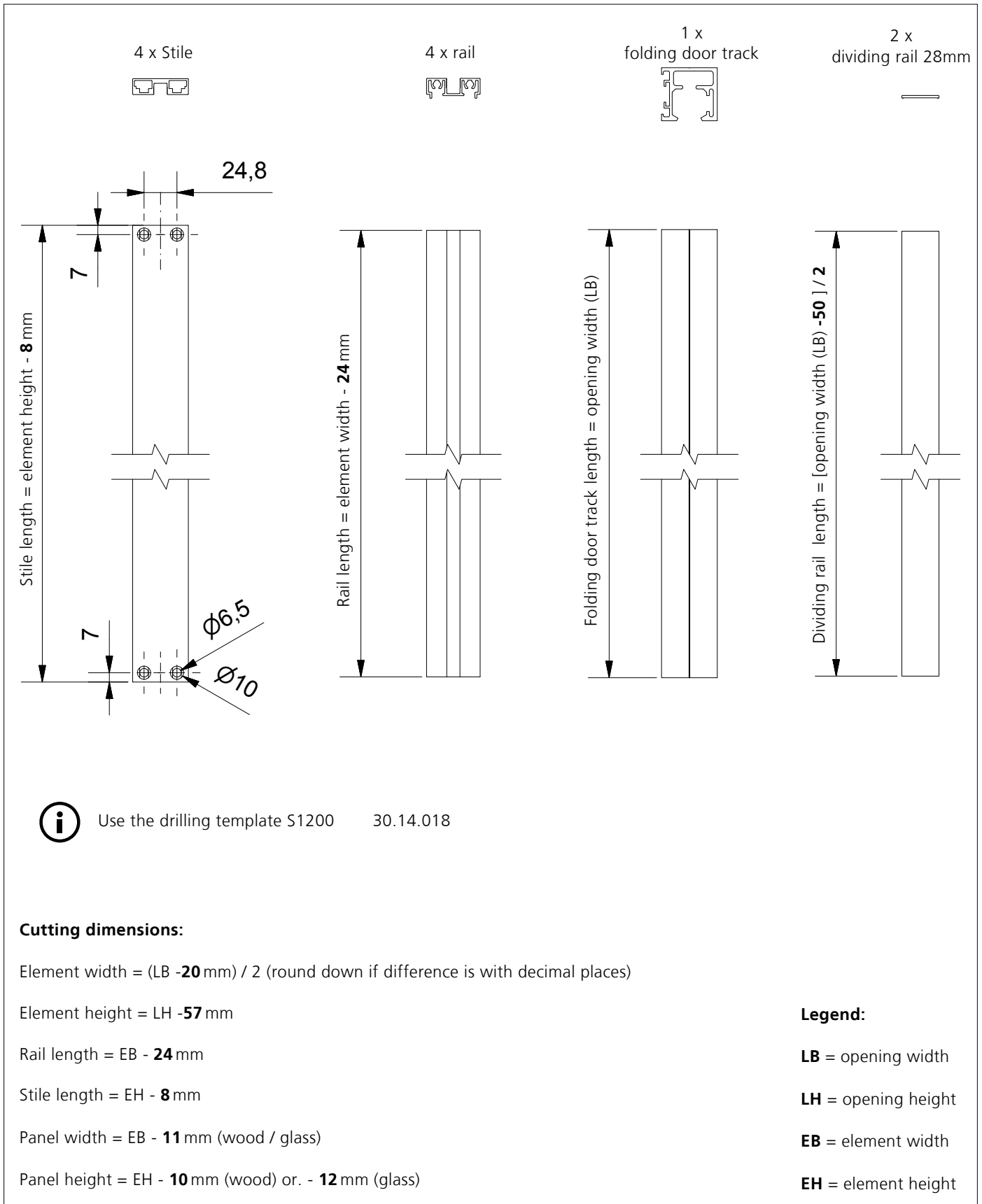

DETAIL DRAWING

DIN LEFT

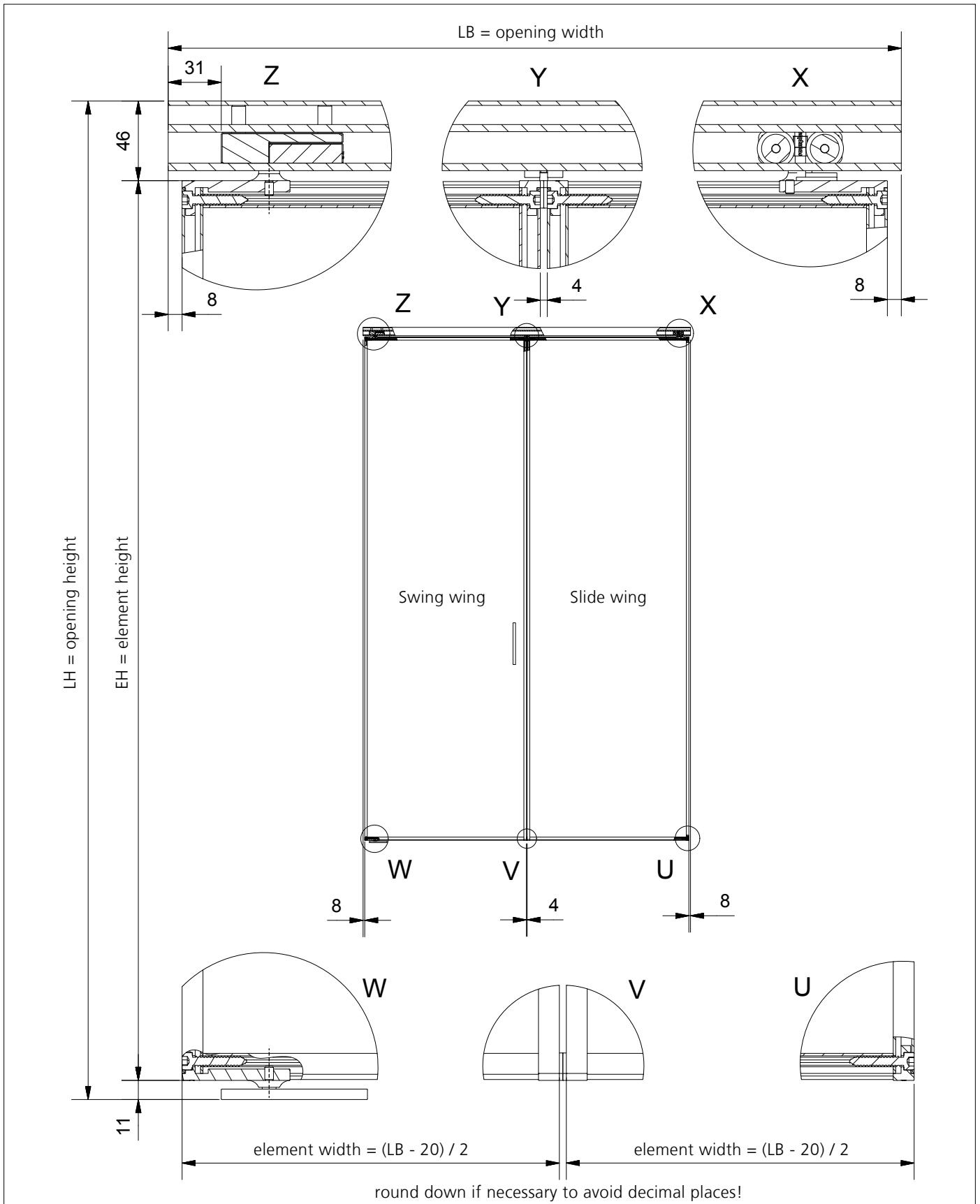

3_

DETAIL DRAWING

HINGE DIN LEFT / DIN RIGHT

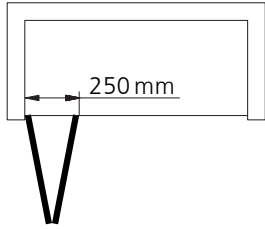

The folding door reduces clear passage to approx **250 mm** (measured from wall to outer edge of folding door). Distance to Interior system **100 mm**, from the top track to outer edge of Interior system.

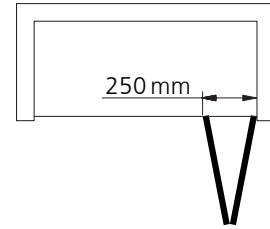

DIN LEFT
top hinge

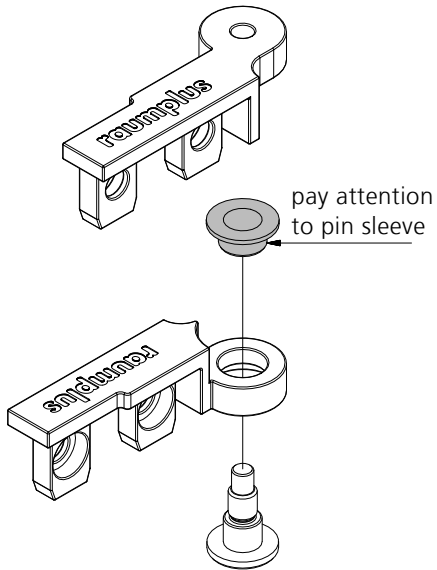

DIN RIGHT
top hinge

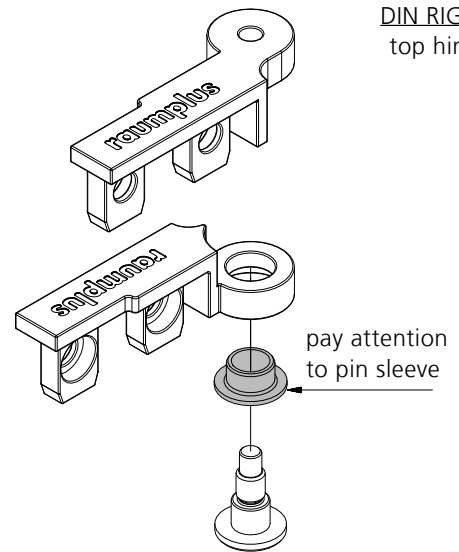

DIN LEFT
bottom hinge

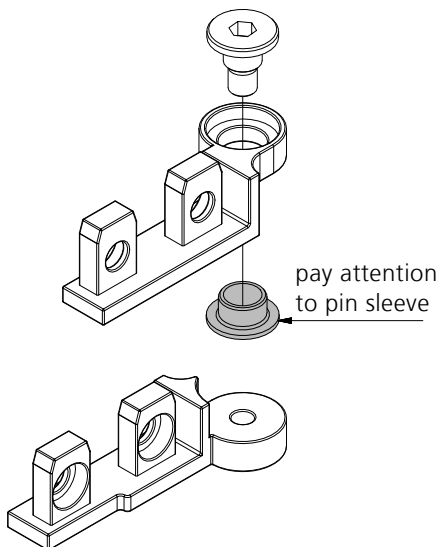

DIN RIGHT
bottom hinge

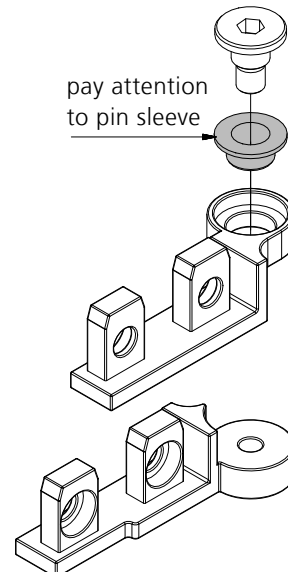

ASSEMBLY INSTRUCTION

DIN LEFT – SLIDE WING AND SWING WING

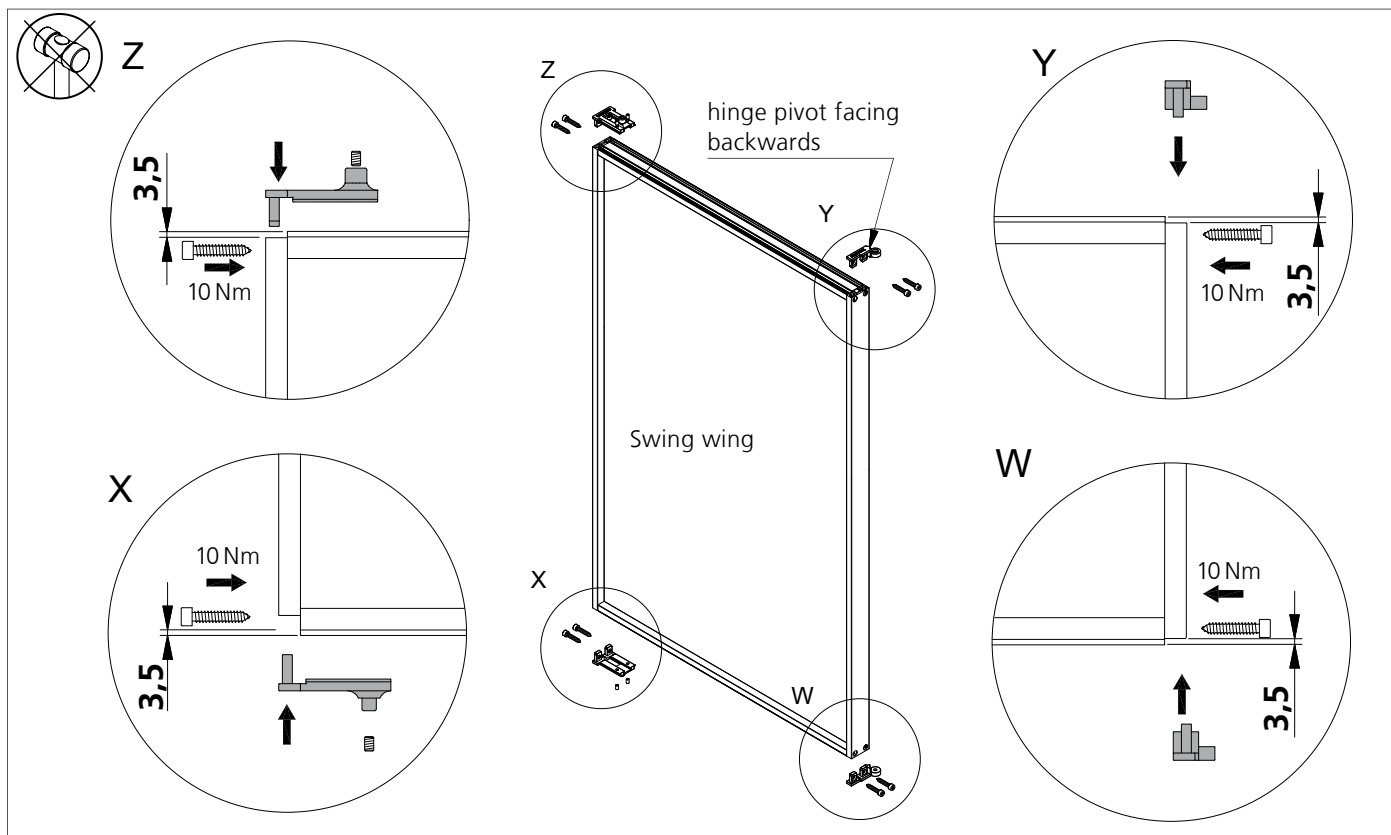

1_ Swing wing (DIN LEFT), do not use a hammer!

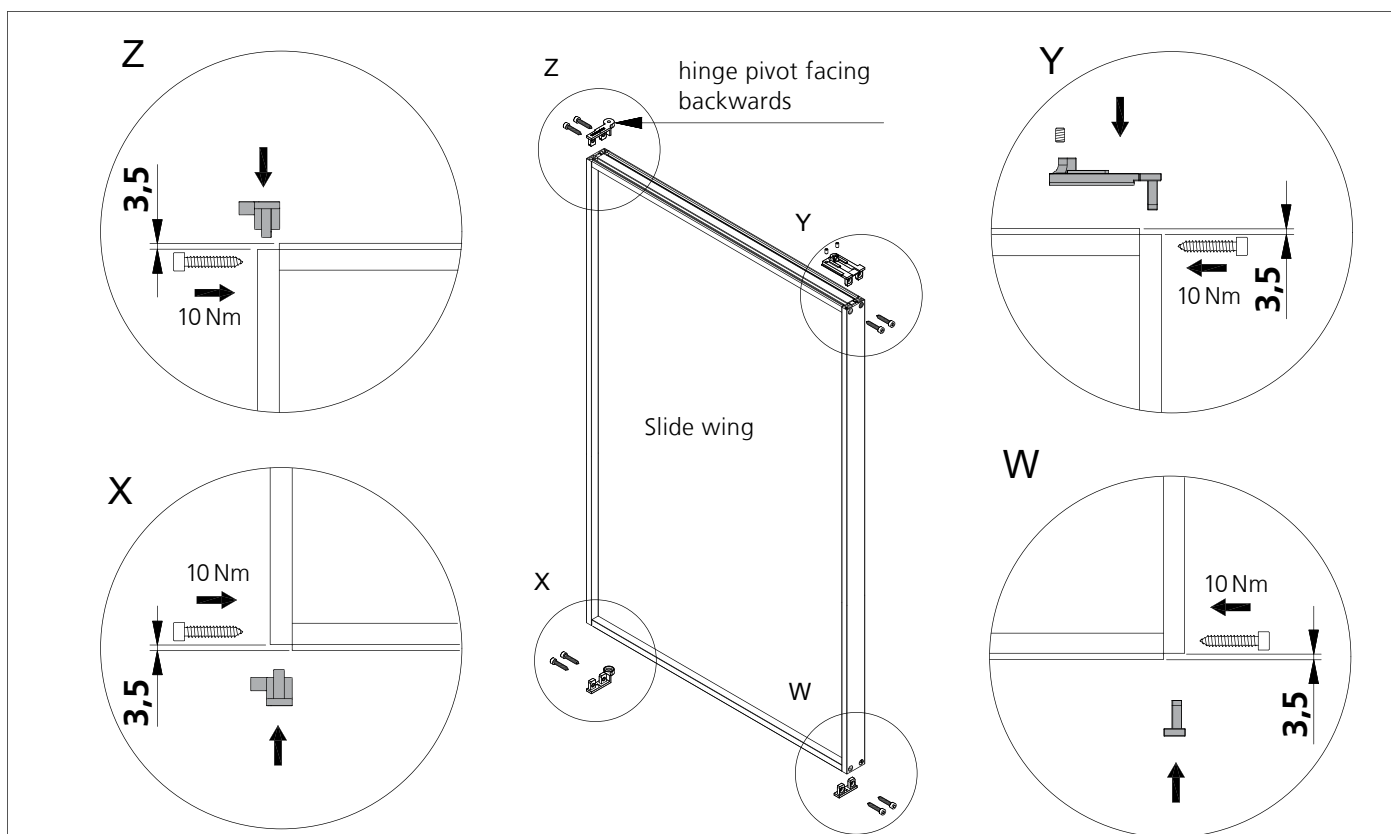

2_ Slide wing (DIN LEFT), do not use a hammer!

ASSEMBLY INSTRUCTION

DIN LEFT

Pay attention to orientation and position of pin sleeve!

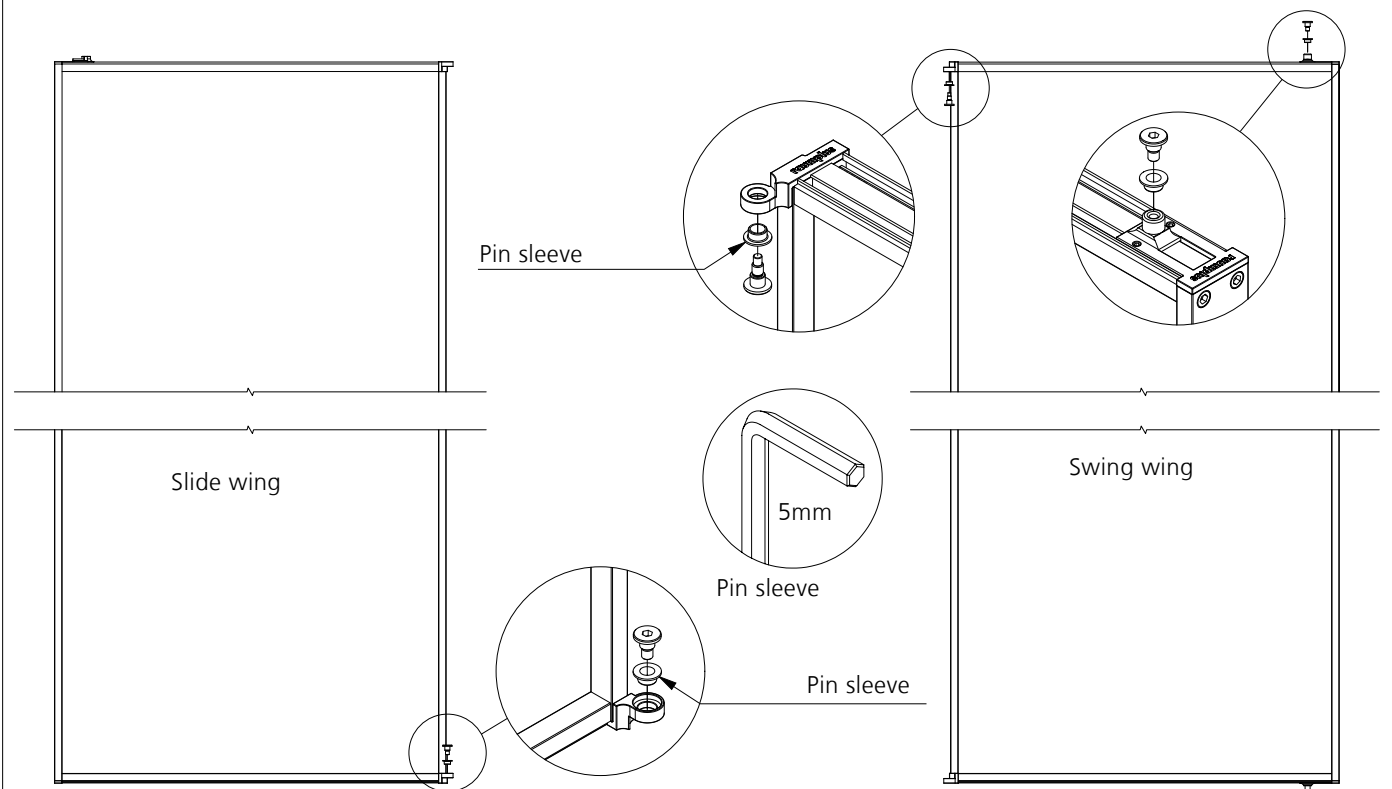

3_ Swing wing and slide wing (fi. back **DIN LEFT**)