

Solitär Creo Einbau

Solitaire Creo Installation

Version 1.1 (2021-08-03)

5.24.2.ab

Technische Änderungen vorbehalten

Subject to technical changes



	Version	
Produktstart	1.0	<i>Product launch</i>
Anzugsdrehmoment hinzugefügt	1.1	<i>tightening torque added</i>

Produktinformation

Bestimmungsgemäße Verwendung

Zur bestimmungsgemäßen Verwendung gehört insbesondere die fachgerechte Montage, gemäß unserer Montageanleitung. Die Beschläge müssen an allen relevanten Stellen ausreichend und dauerhaft befestigt sein. Die Funktion der Beschläge darf durch die Montage nicht beeinträchtigt oder verändert werden. Sonderlösungen sind nur in Absprache mit Ihrem Händler möglich.

Nicht bestimmungsgemäße Verwendung

Gefährdungen können auftreten, wenn z. B.:

- das System unsachgemäß montiert oder gewartet wird.
- die Sicherheits- und Montagehinweise nicht beachtet werden.
- unsachgemäße Montage bzw. nicht ausreichende Befestigung vorliegt.
- das maximale Gewicht der Türen überschritten wird.
- unsachgemäße Stoß- und Fallbelastungen oder sonstige Zusatzlasten an den Beschlägen zur Wirkung kommen.
- die Beschläge im Außenbereich eingesetzt werden.
- Körperteile oder Gegenstände bei der Benutzung des Systems in Schließkanten oder in den Lauf geraten.
- das System nicht bestimmungsgemäß verwendet wird.

Bauliche Veränderungen

Bauliche Veränderungen, die nicht als Zubehör angeboten werden, dürfen nur mit Genehmigung Ihres Händlers angebracht werden.

Produktsicherheit

Das System entspricht dem Stand der Technik und den anerkannten sicherheitstechnischen Regeln zum Zeitpunkt der Auslieferung.

Technische Änderungen vorbehalten.

Haftung

Gemäß der im „Produkthaftungsgesetz“ definierten Haftung des Herstellers (§4 ProdHG) für seine Produkte sind die in diesem Heft angeführten Informationen zu beachten. Die Nichtbeachtung entbindet den Hersteller von seiner Haftungspflicht.

Product information

Designated use

The prerequisite for the intended use of our products is the professional installation according to our installation instruction. Sufficient fittings must be available and durably installed to all relevant places. The function of the fittings must not be hindered or altered during installation. Special solutions are only possible in consultation with your supplier.

Incorrect use

Risk or danger may occur in the following cases:

- *the door system has improperly been installed or maintained*
- *the safety and installation instructions have not been followed.*
- *after improper installation or inadequate fixing (e.g. to parts of buildings)*
- *the maximum weight of the doors has been exceeded.*
- *improper shock and case loads or other additional loads on the fittings have occurred*
- *the fittings have been used outside.*
- *body parts or objects got into the closing edges or door runnings during use of the door wing.*
- *the door system is not used as intended.*

Structural modifications

Structural modifications that are not offered as an accessory may only be attached or installed in consultation with your supplier!

Product safety

The System complies with the prior of the art and the authorized safety rules at the time of delivery.

Subject to technical changes.

Liability

As defined in the „Law of Liability for Products“ (§4 Prod-HG), for the liability of the manufacturer, for his products, the information in this booklet has to be regarded. The disregard of this manual, releases the manufacturer from his liability.

Solitär Creo

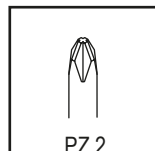
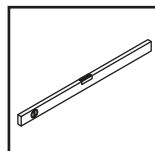
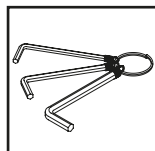
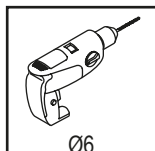
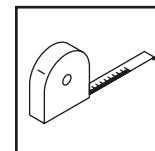
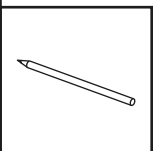
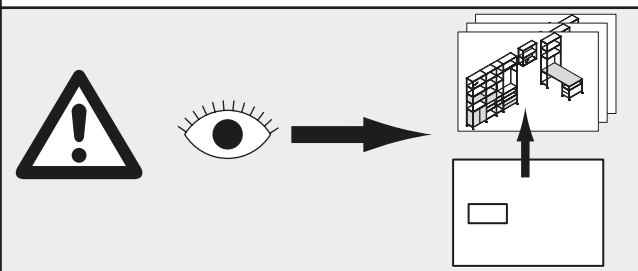
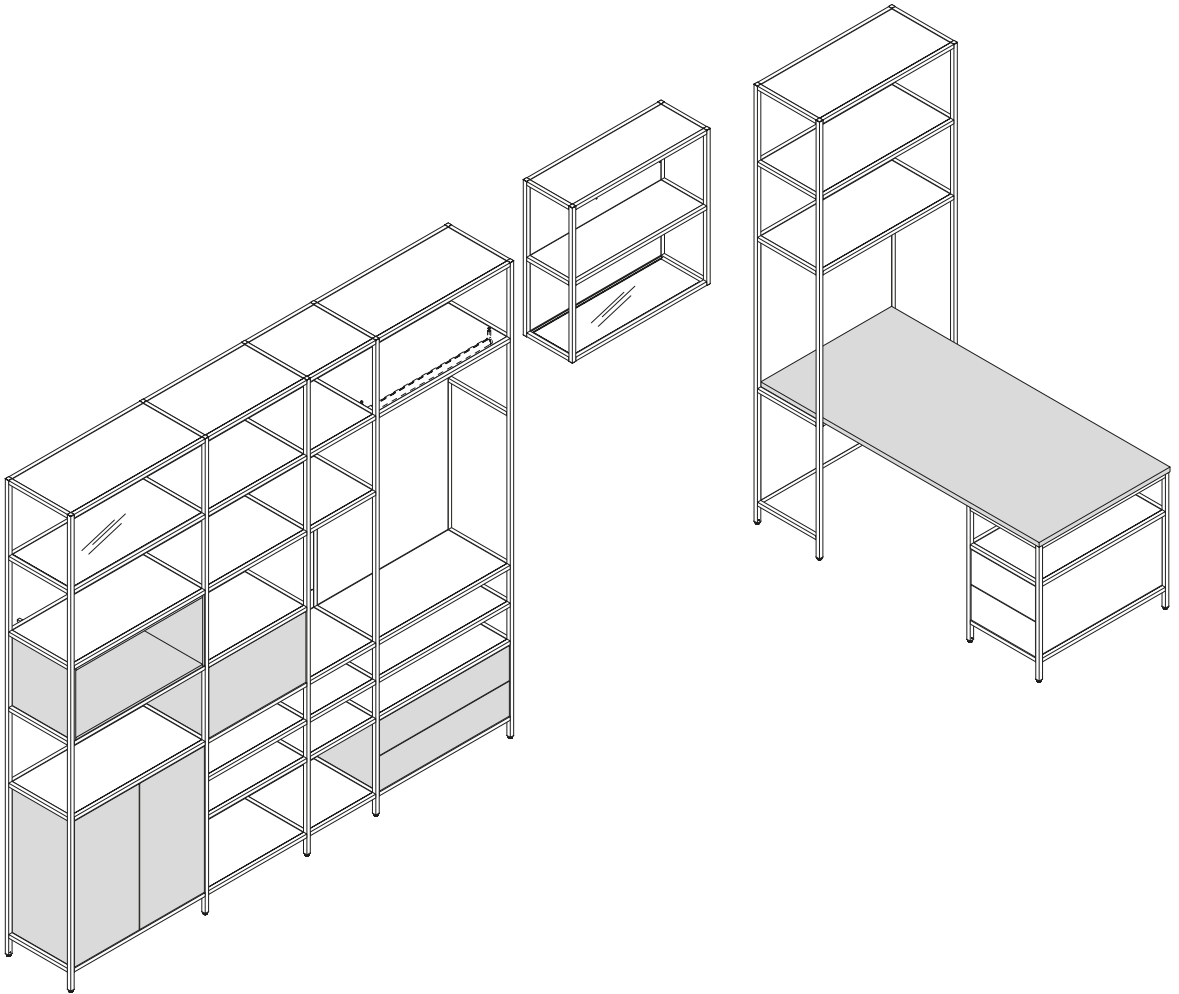
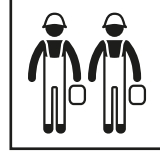
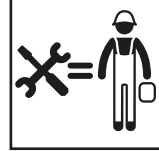
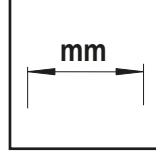

0001 | 03-2021 | Alurahmensystem

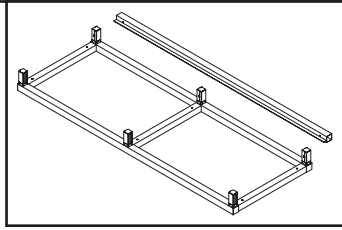

1 - 12

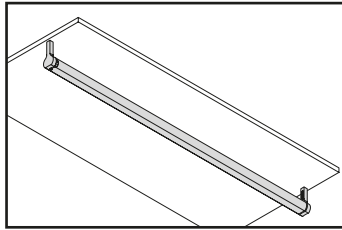

13 - 14

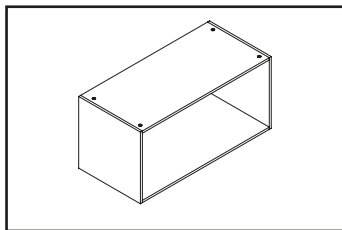

15 - 22

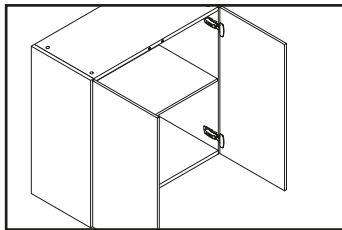

23 - 36

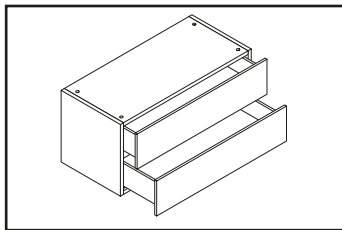

37 - 47

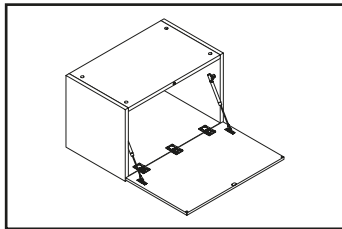

48 - 63

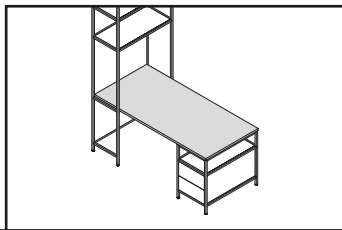

64 - 68

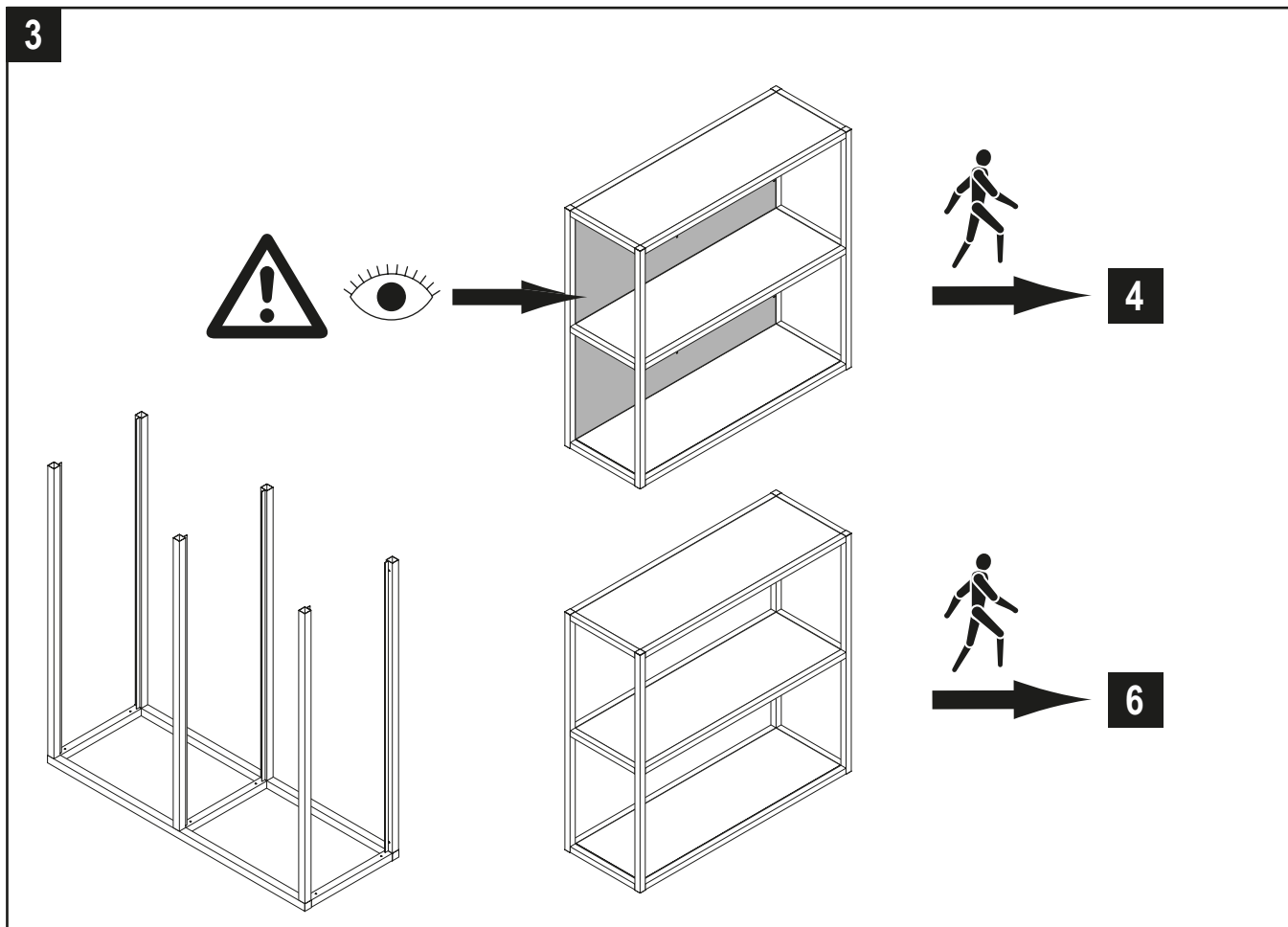
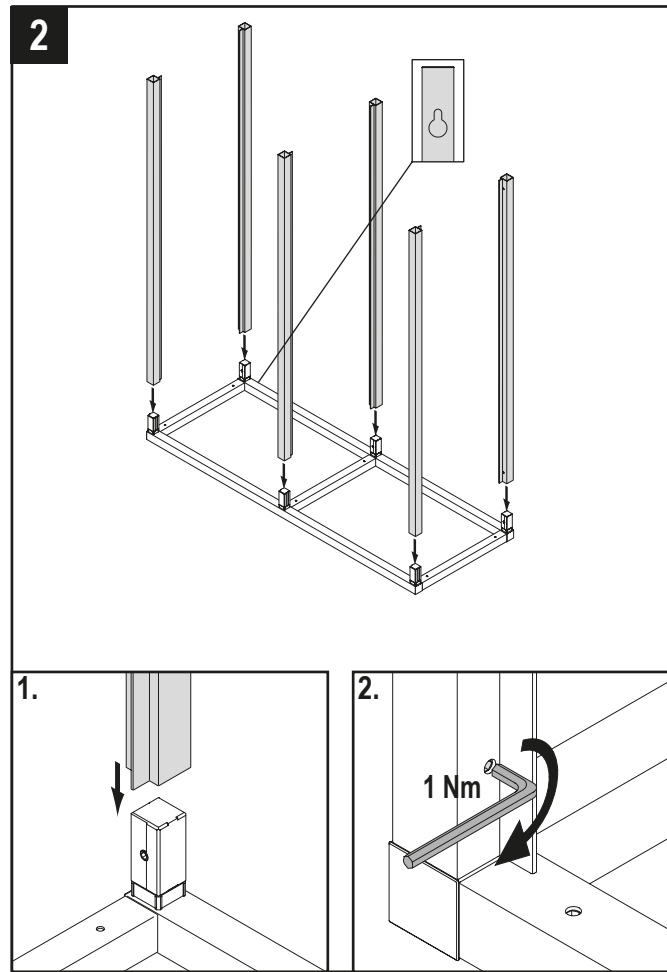
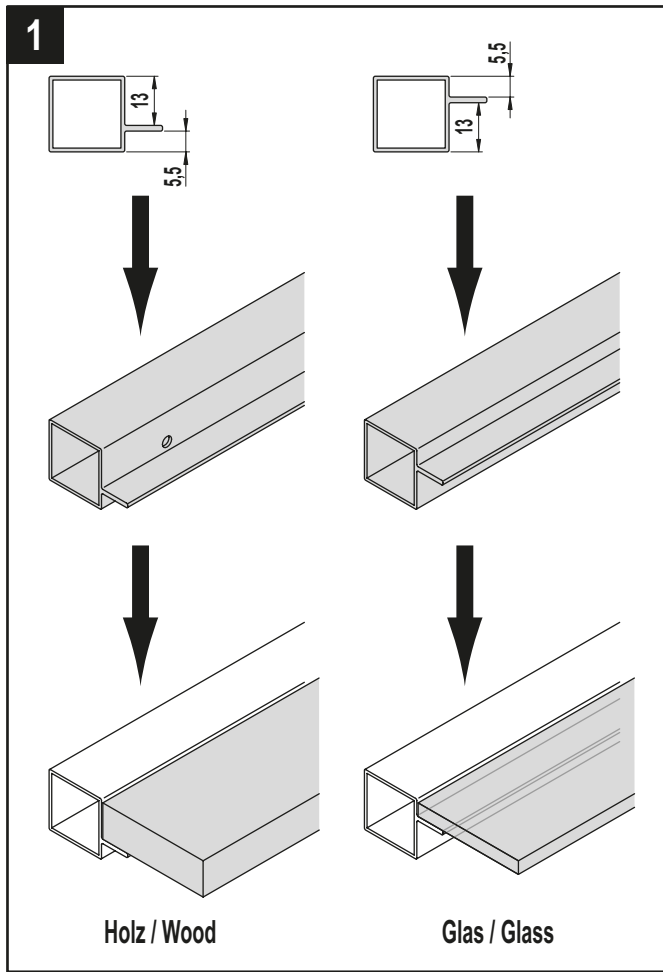

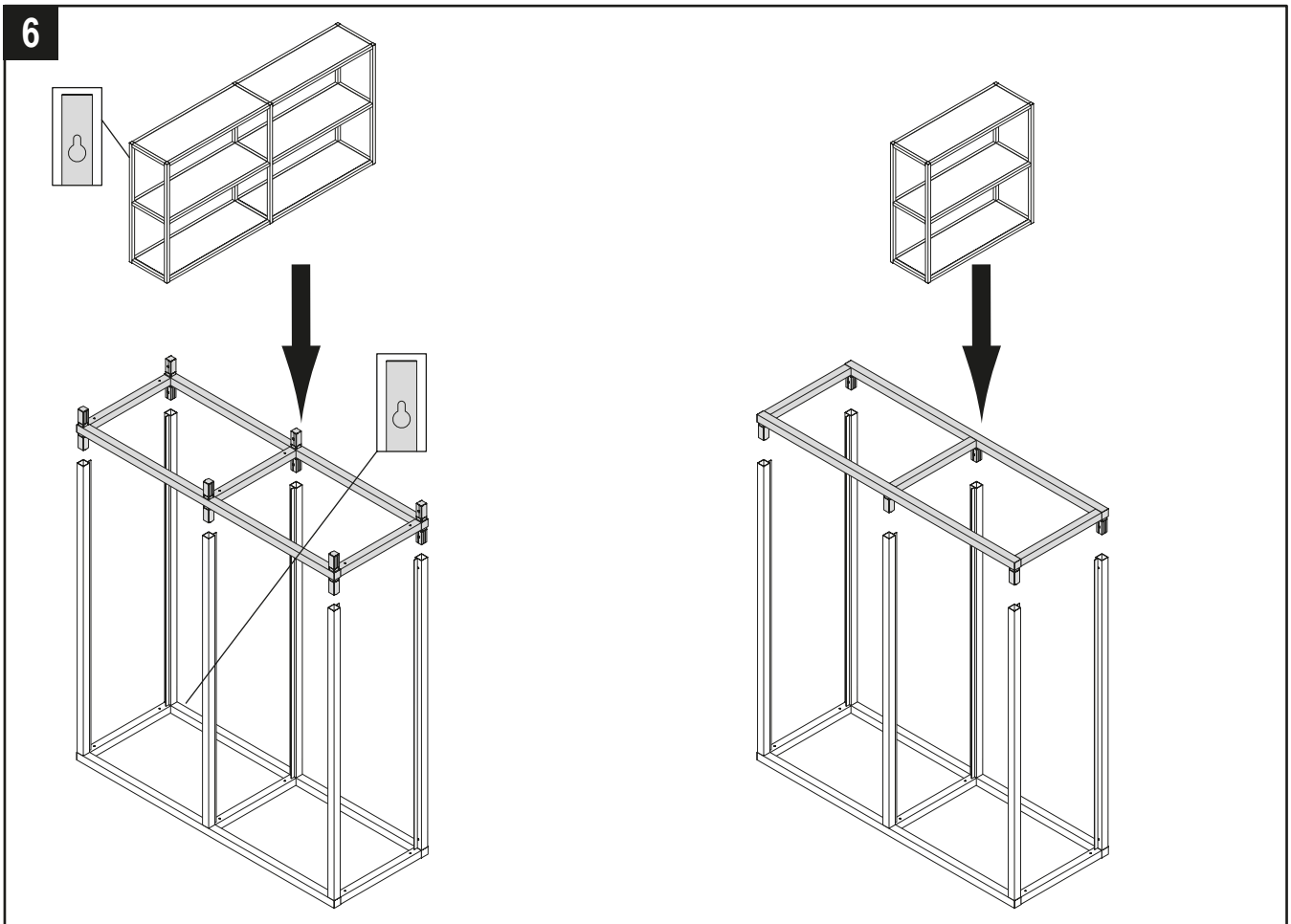
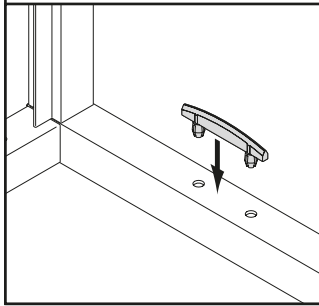
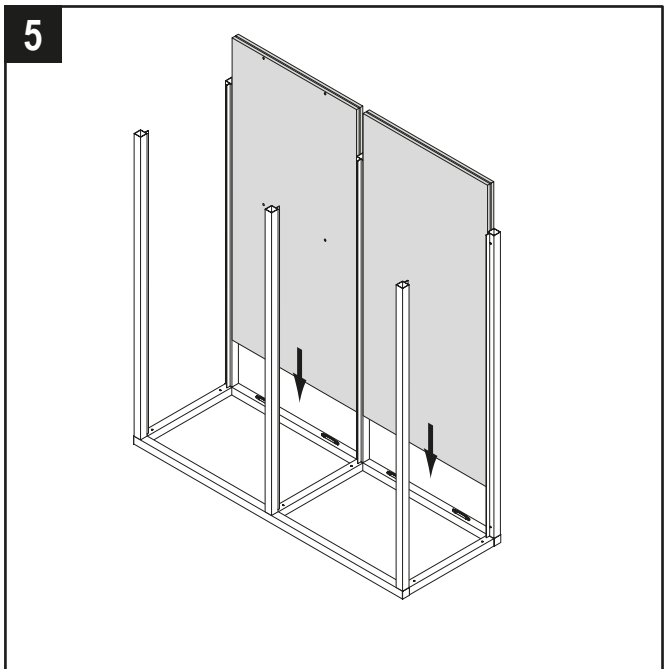
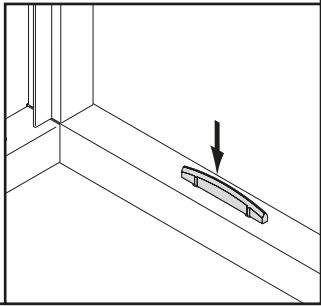
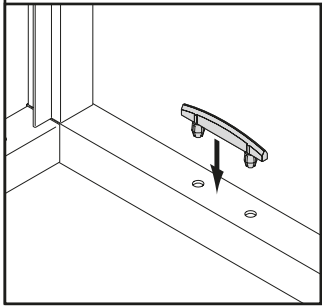
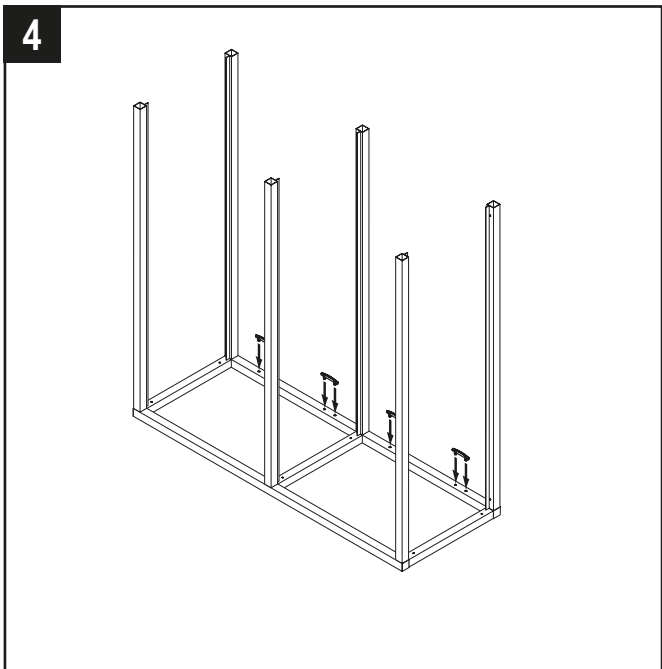

7

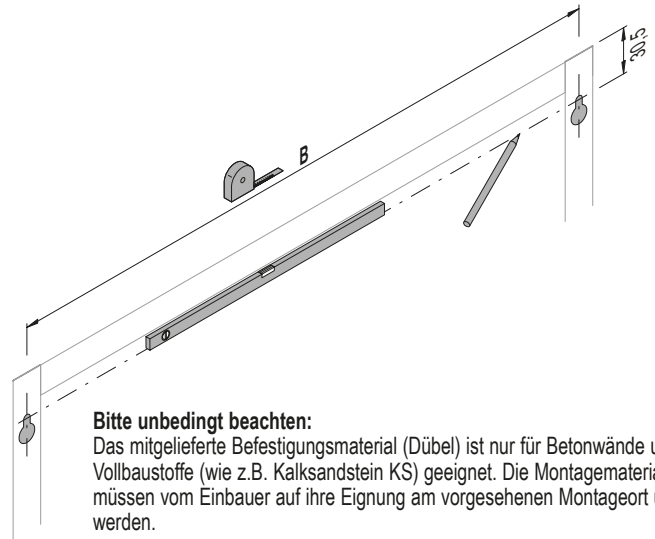
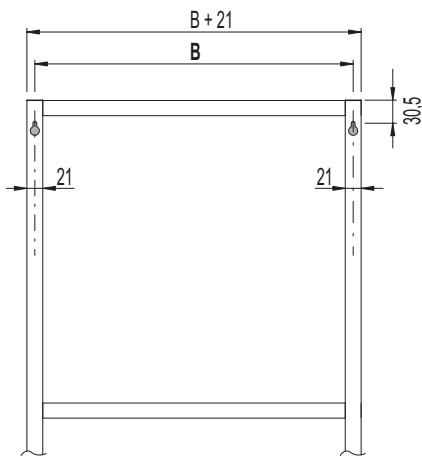
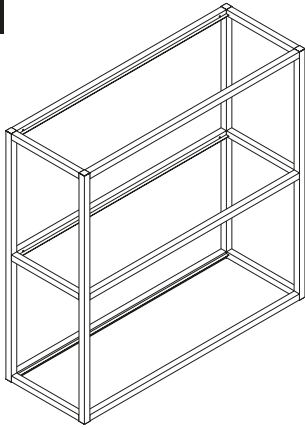

Bitte unbedingt beachten:

Das mitgelieferte Befestigungsmaterial (Dübel) ist nur für Betonwände und Vollbaustoffe (wie z.B. Kalksandstein KS) geeignet. Die Montagematerialien müssen vom Einbauer auf ihre Eignung am vorgesehenen Montageort überprüft werden.

Important:

The fixings supplied (anchors) are only suitable for concrete walls and solid building materials (such as sand-lime brick). The installer must check the suitability of the installation materials for the intended installation location.

1.

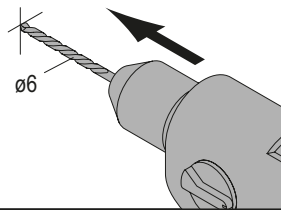

2.

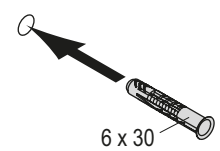

8

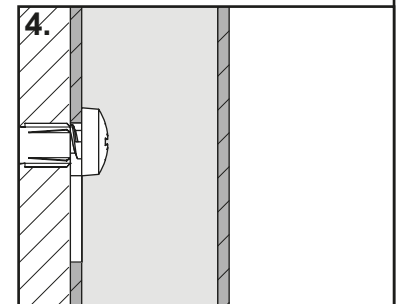
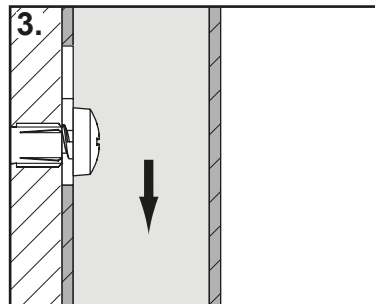
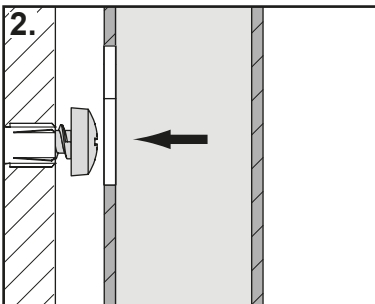
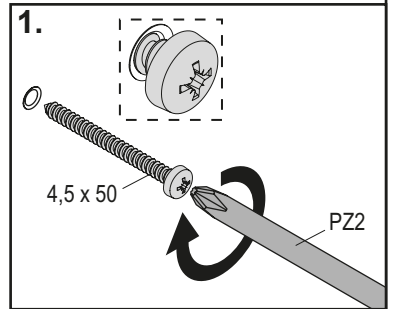
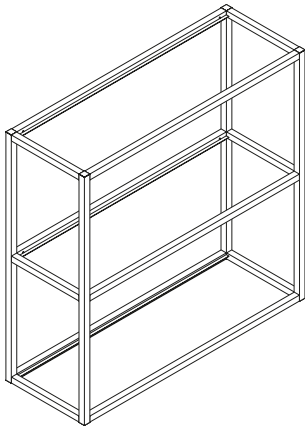

9

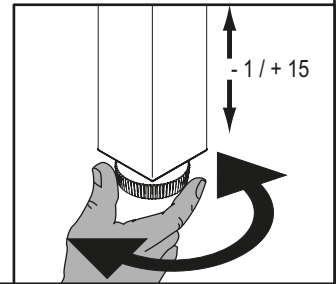
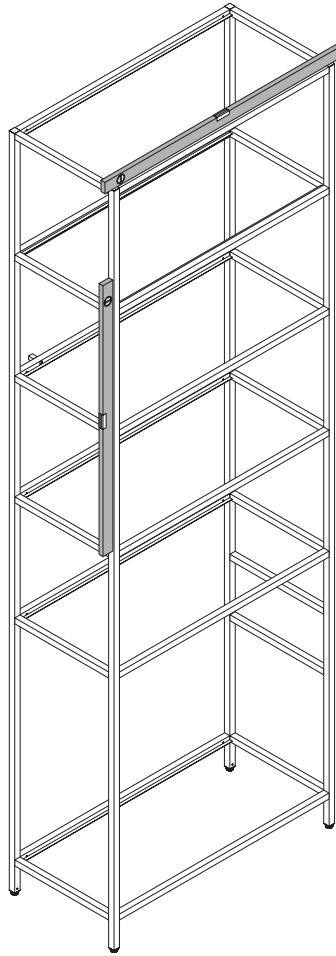

10

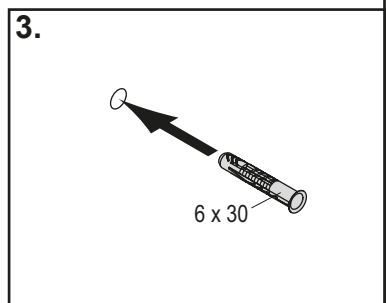
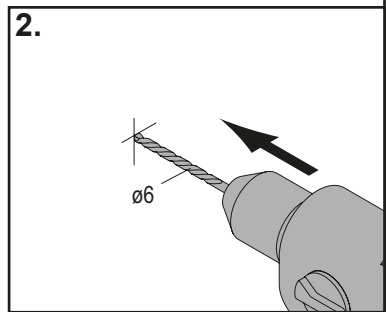
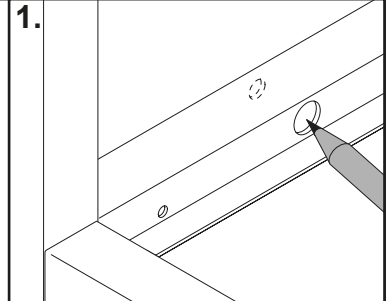
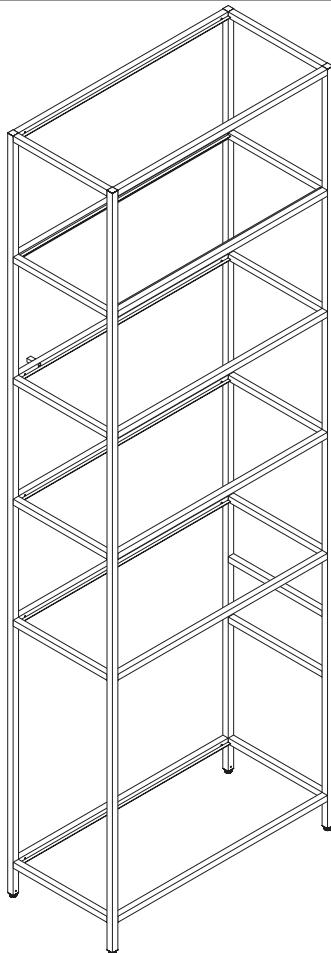

11

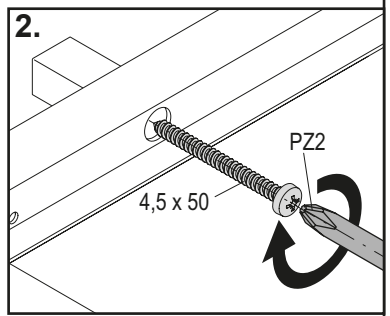
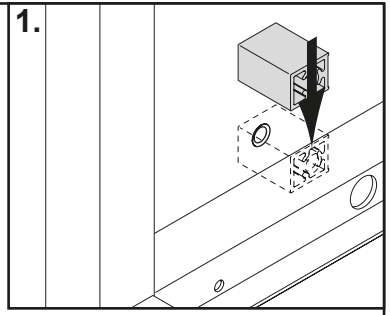
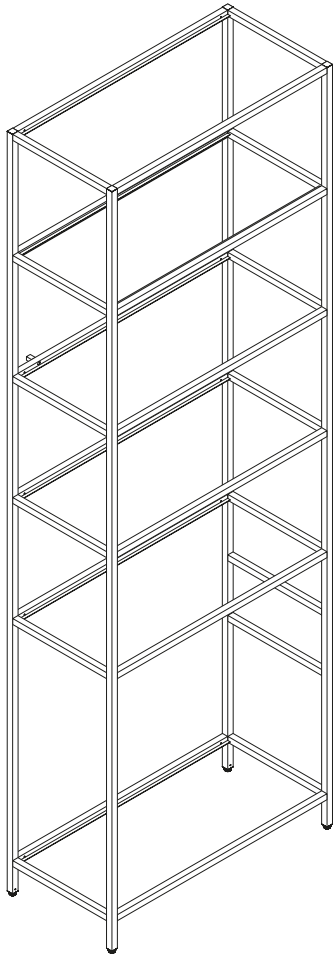

12

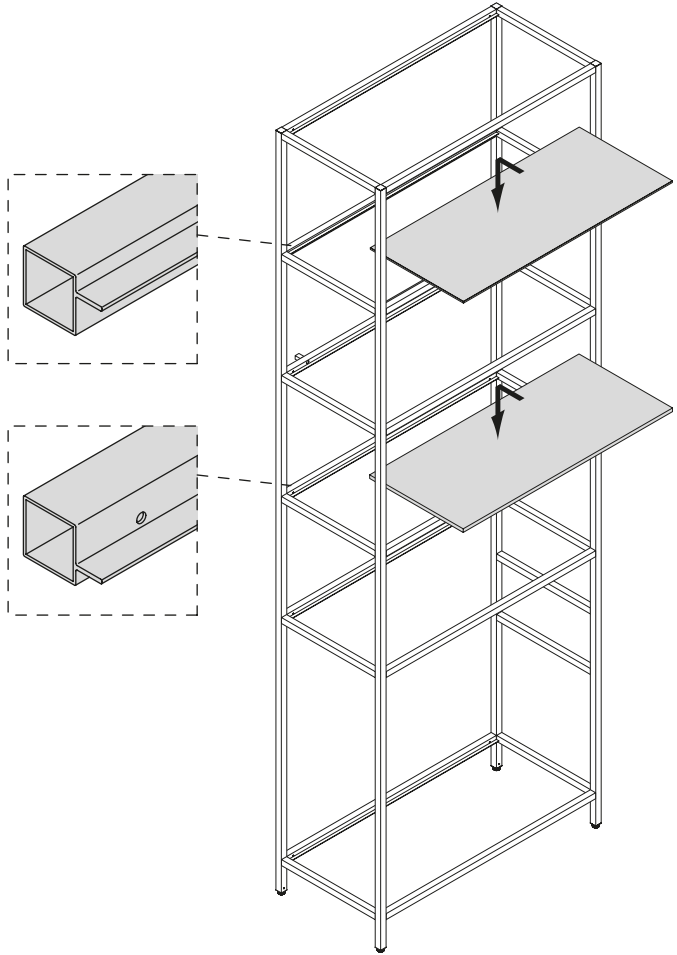

13

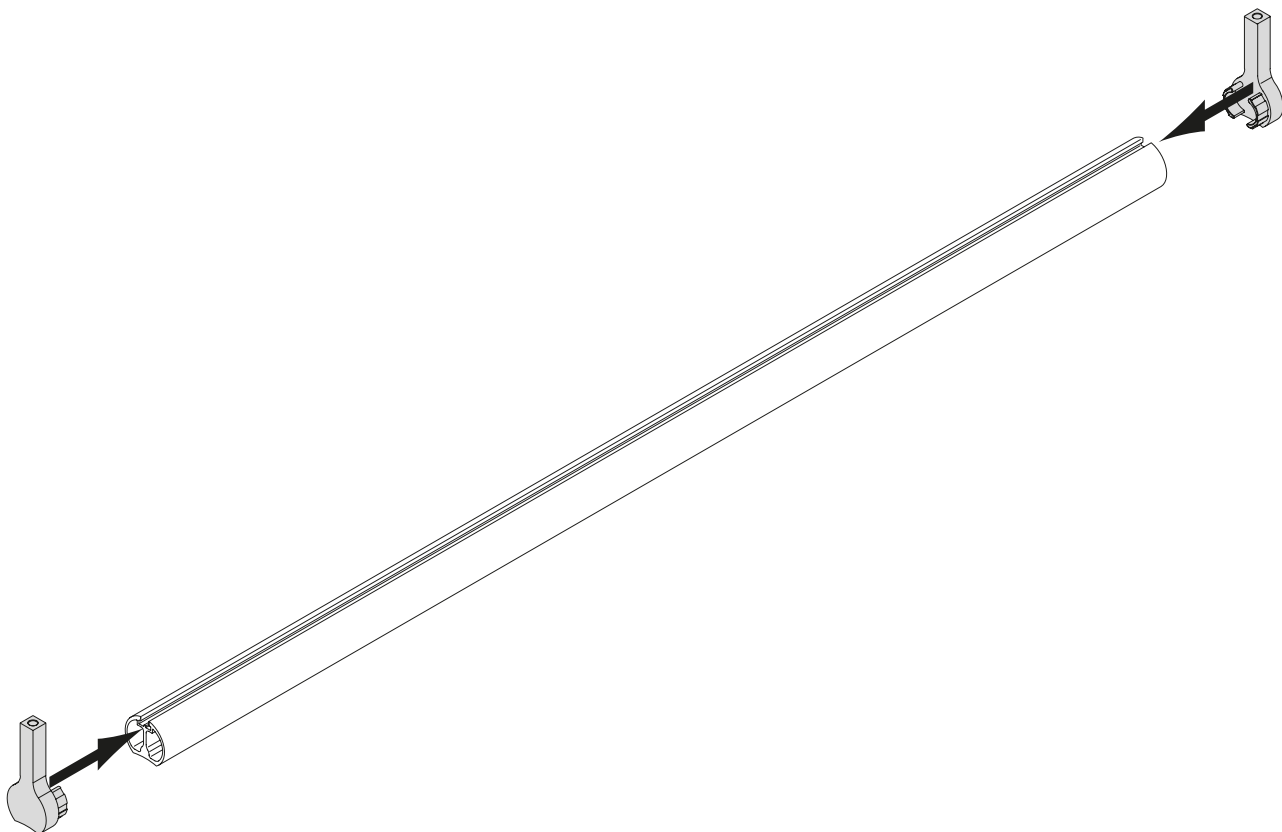

14

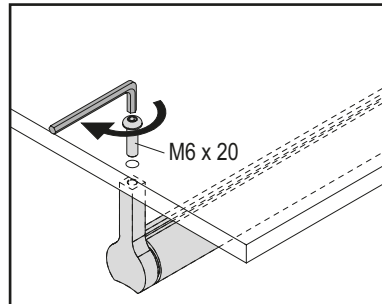
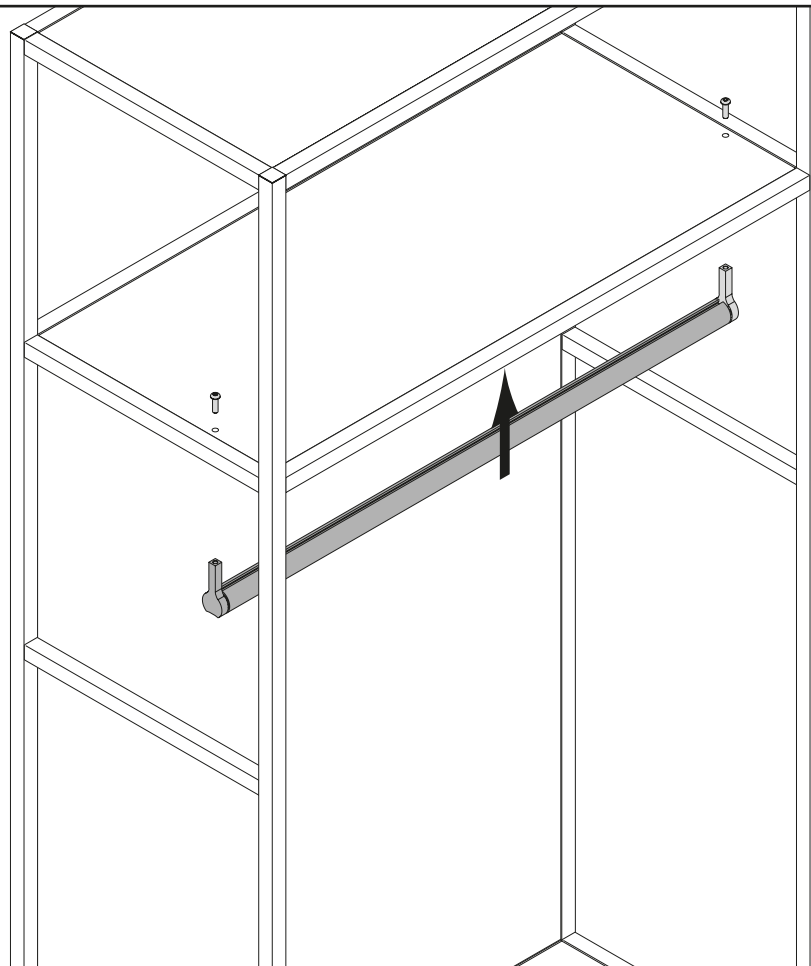

15

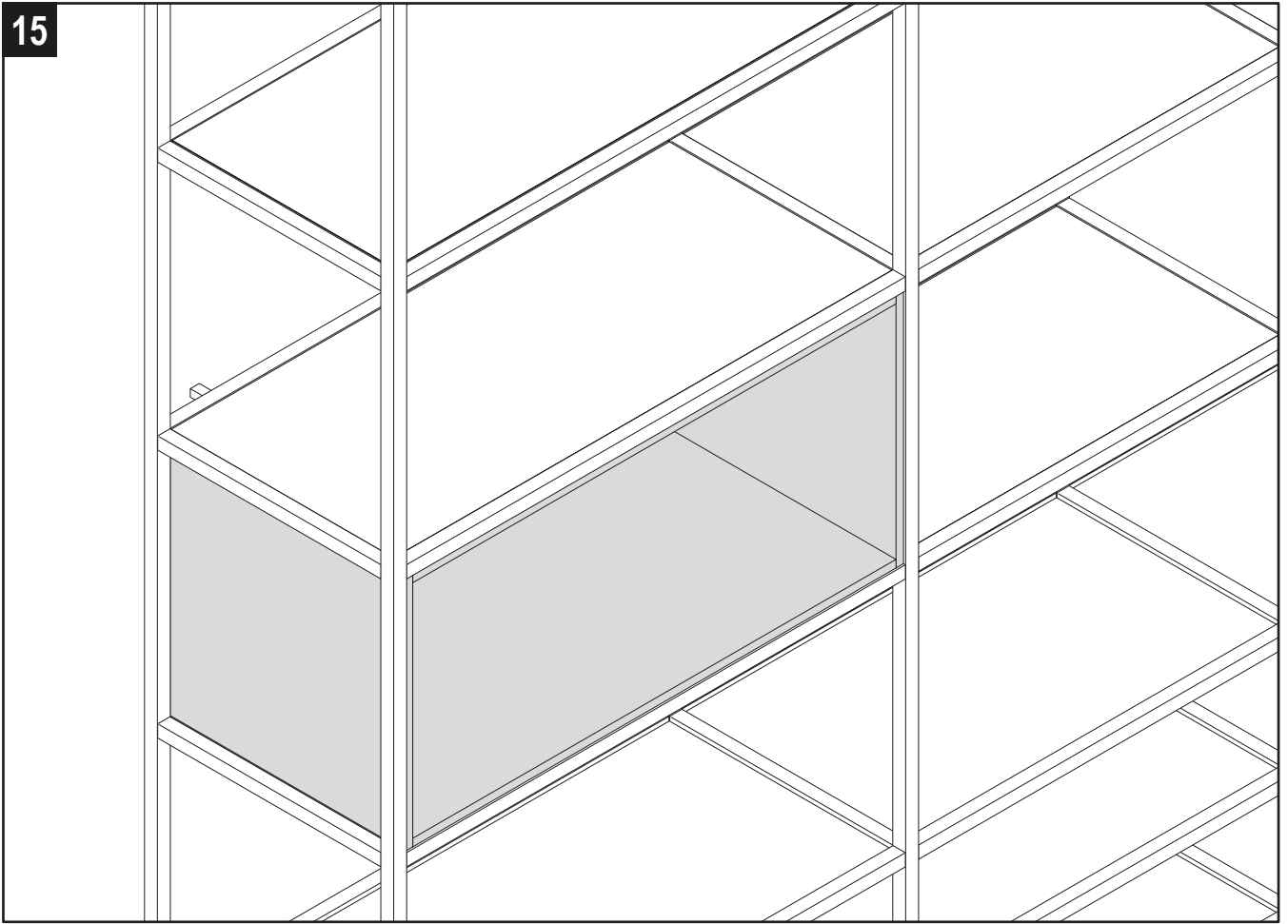

16

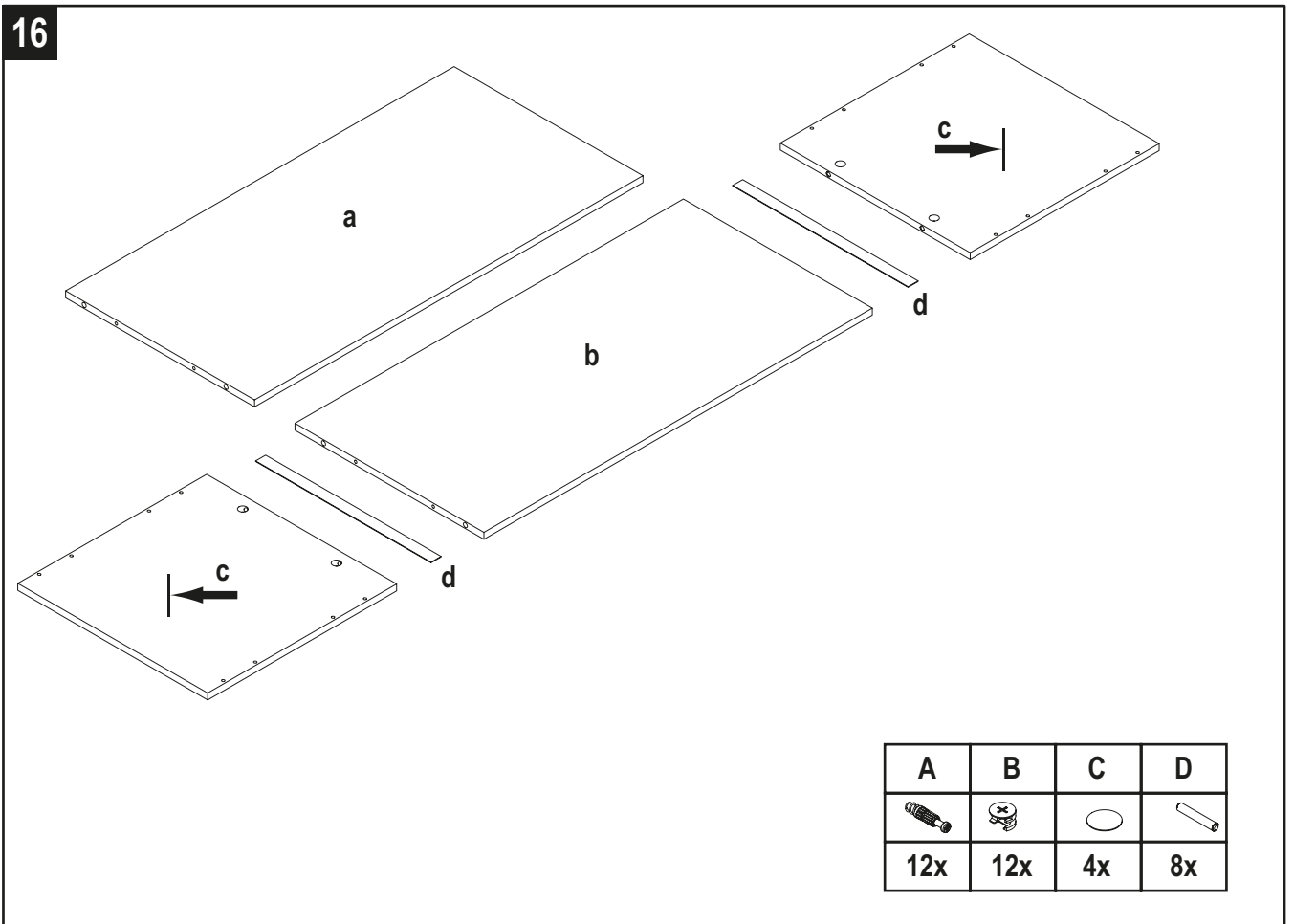

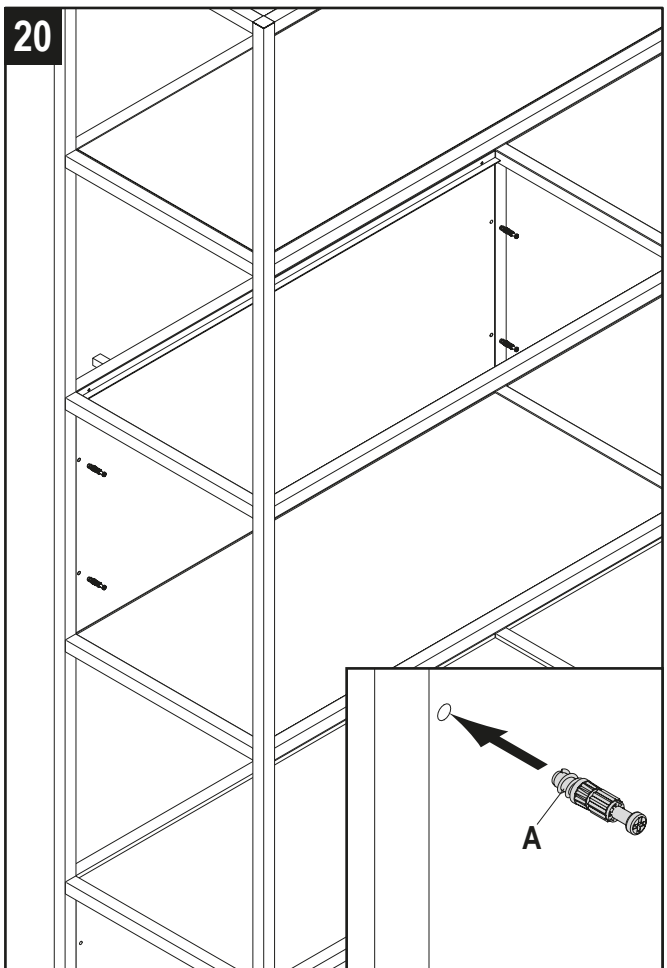
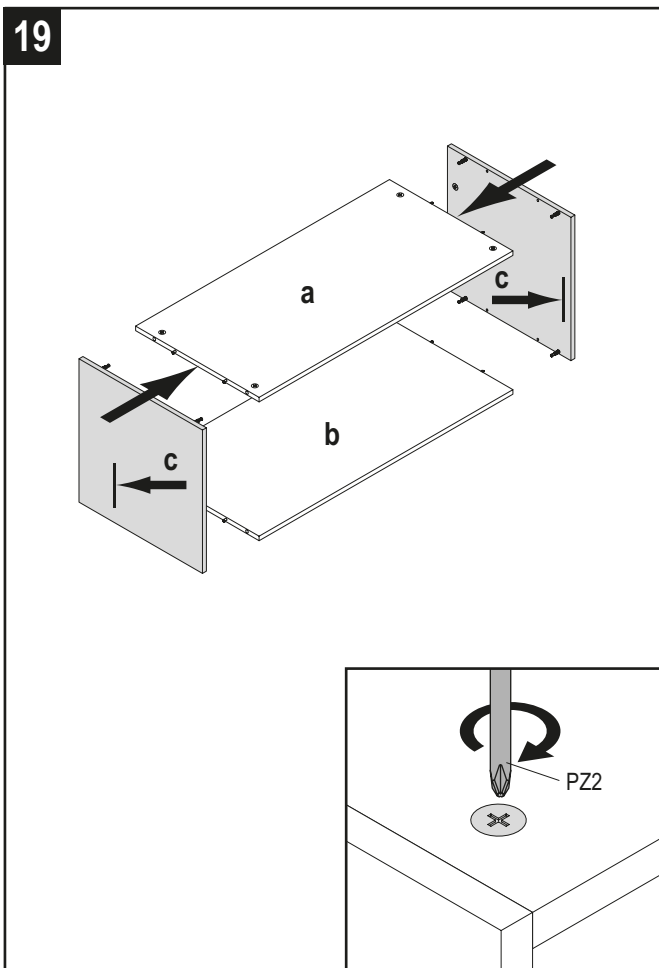
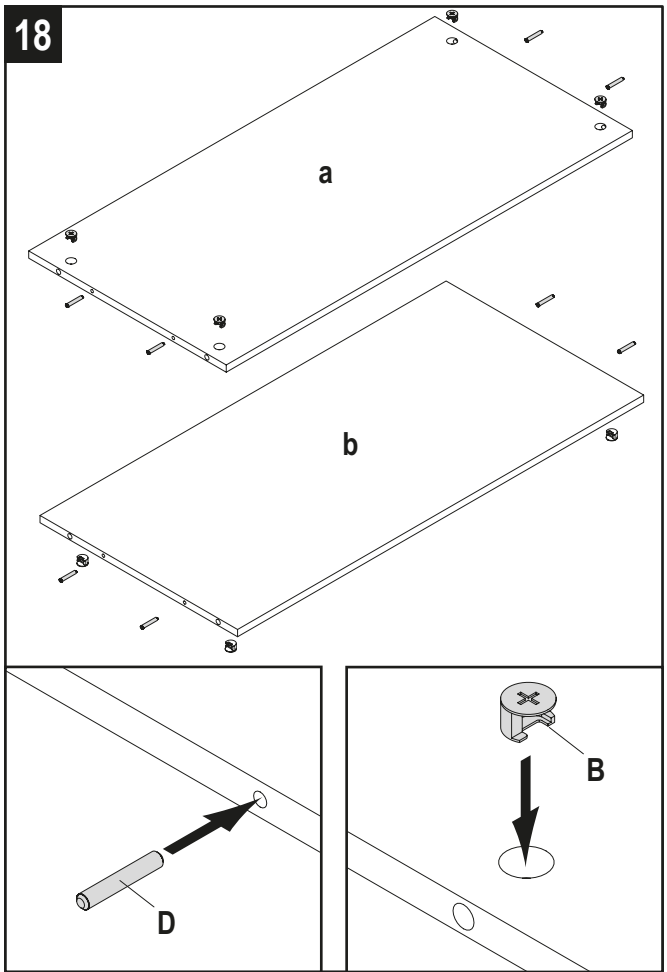
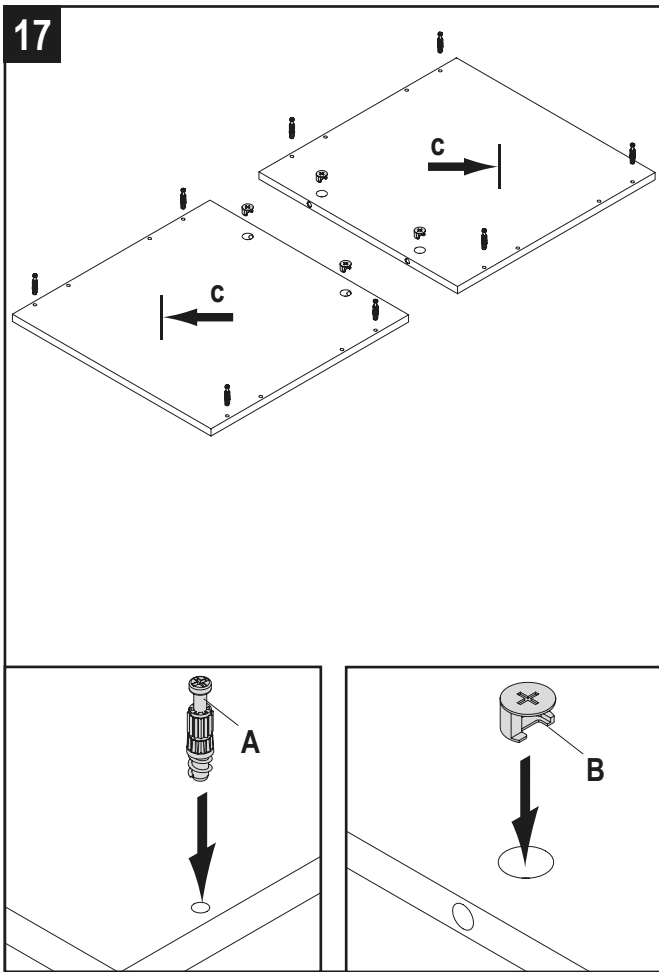

21

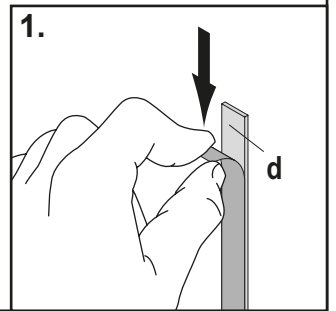
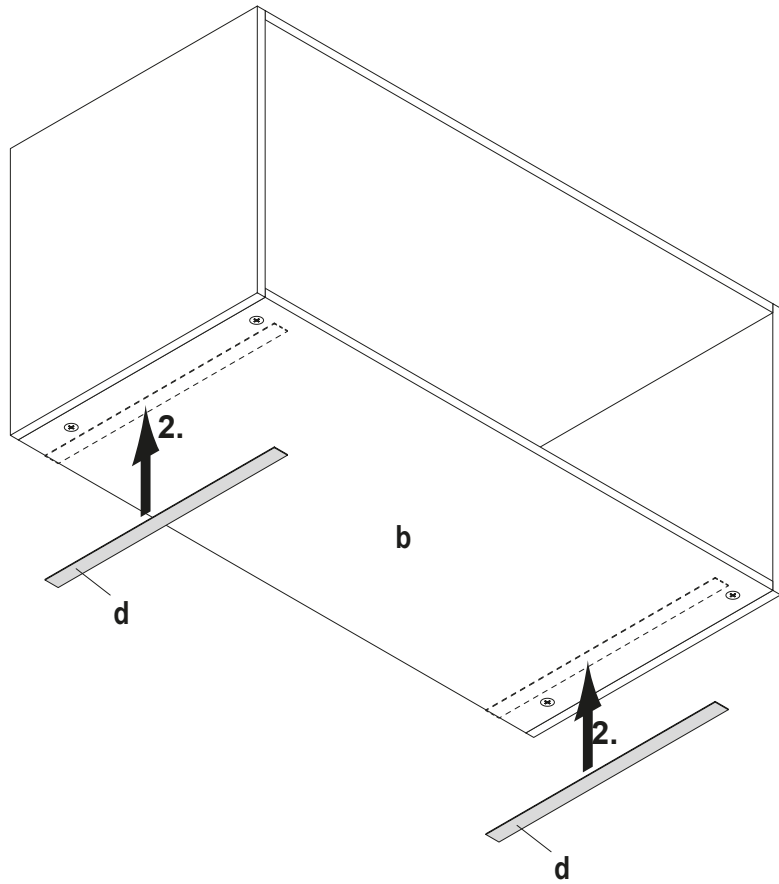

22

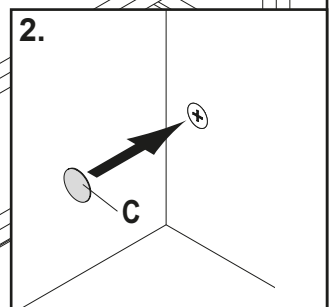
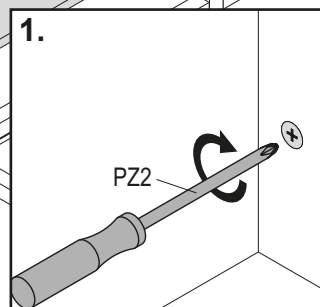
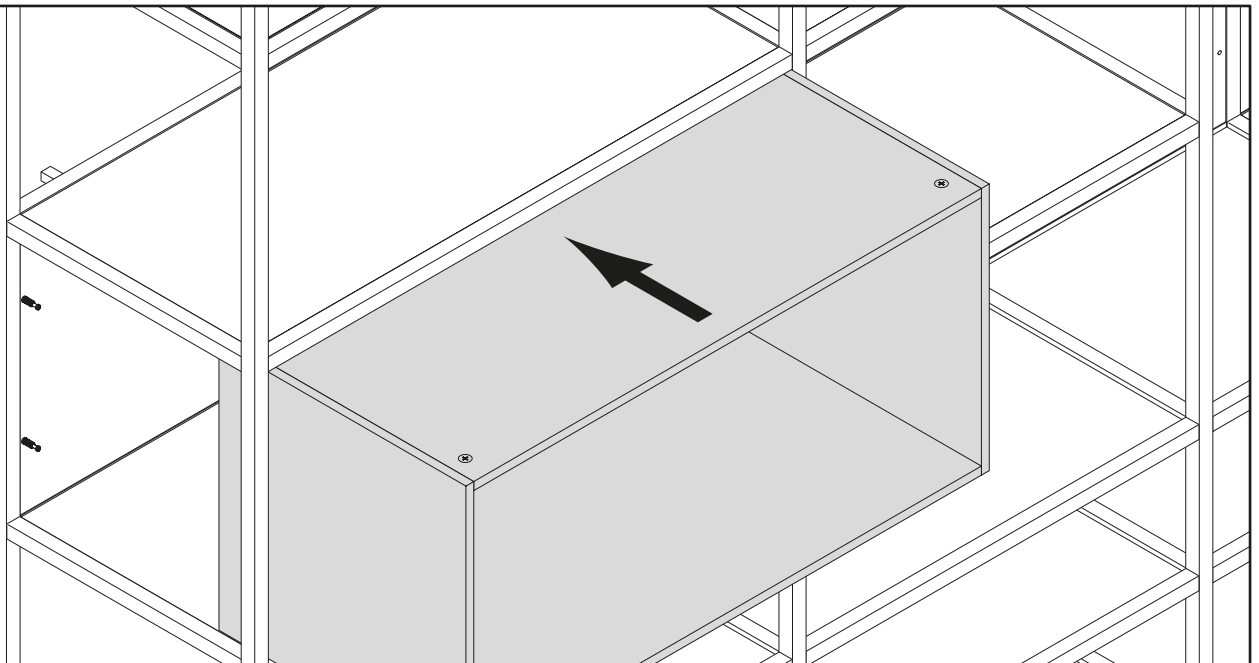



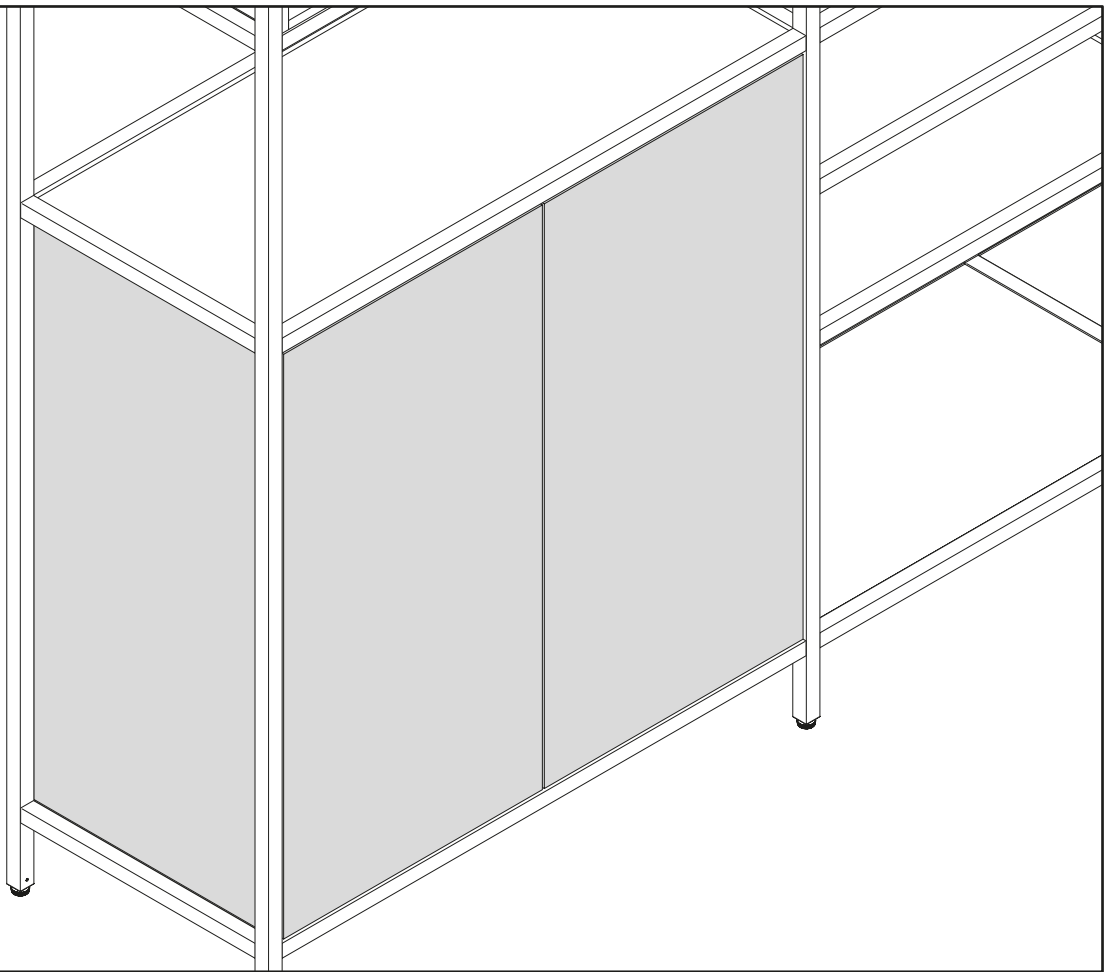



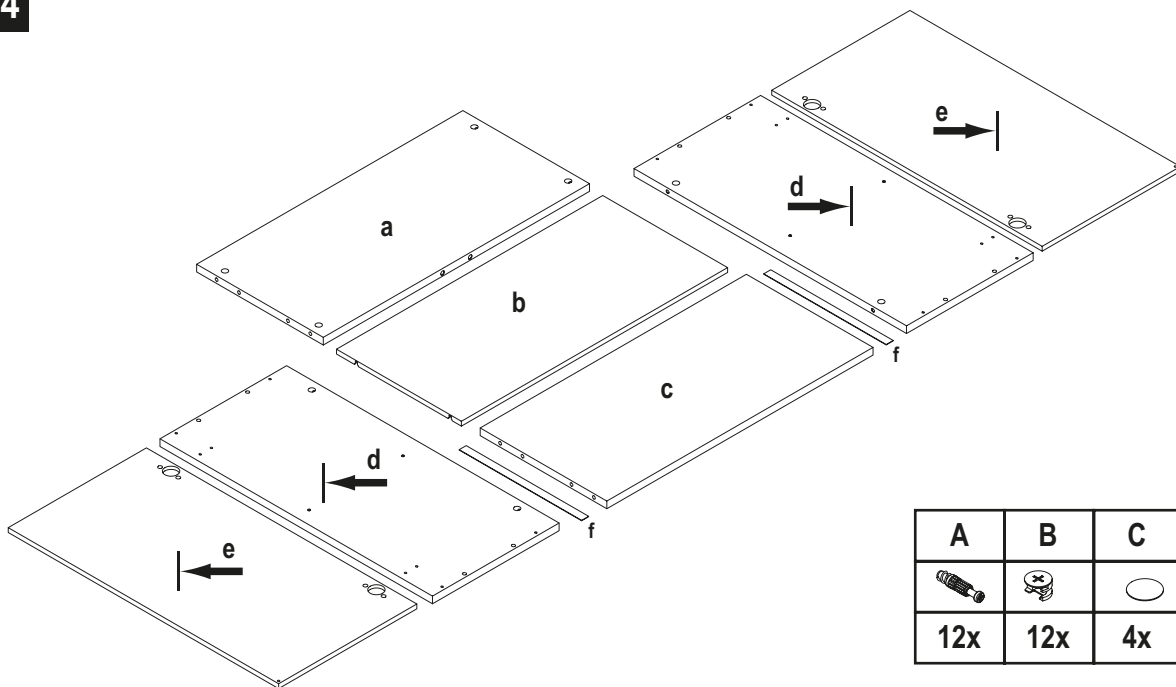

23



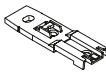

24

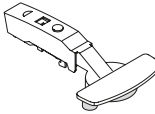

A	B	C	D
			
12x	12x	4x	8x

E	F	G	H	I	J	K
						
8x	4x	4x	4x	4x	2x	4x

N	O
	
1x	2x

25

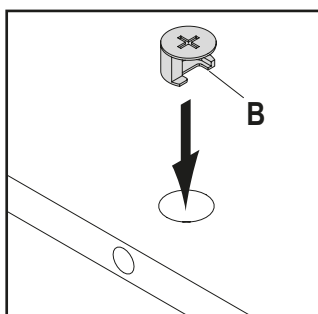
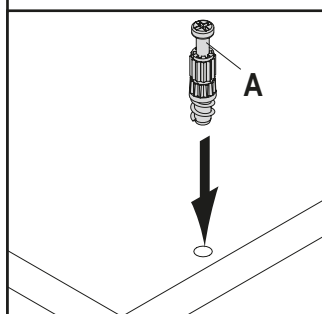
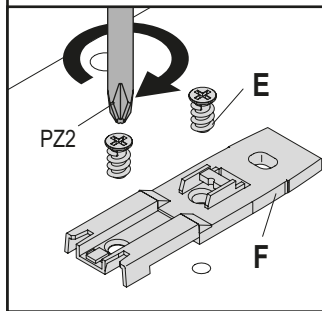
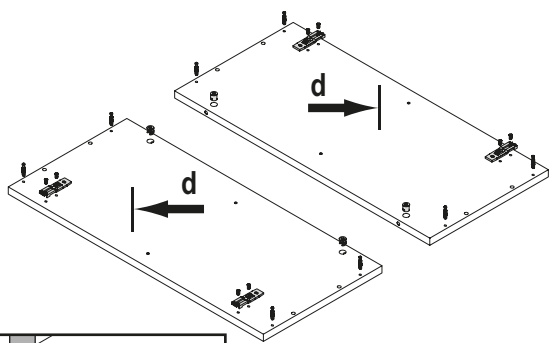

26

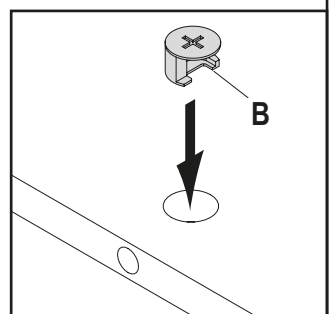
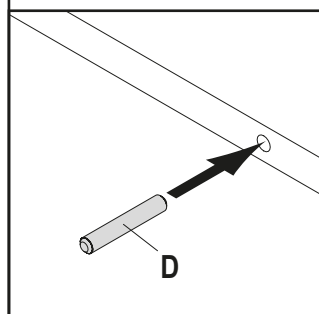
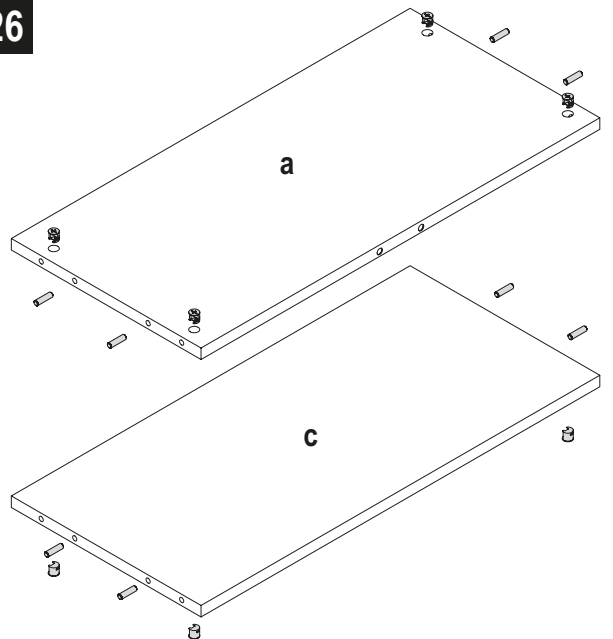

27

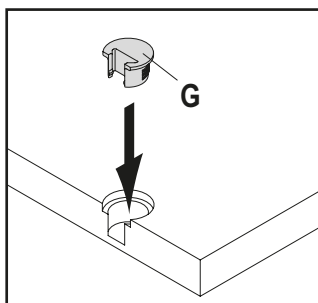
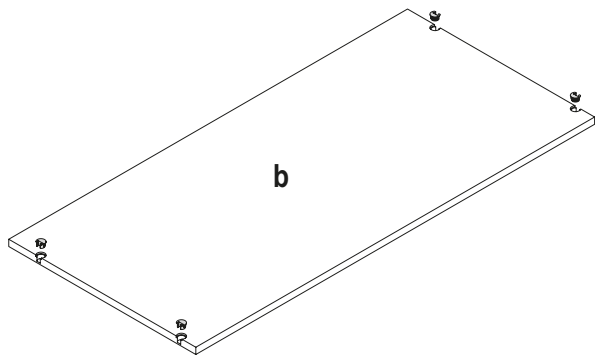

28

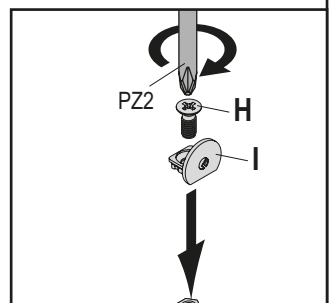
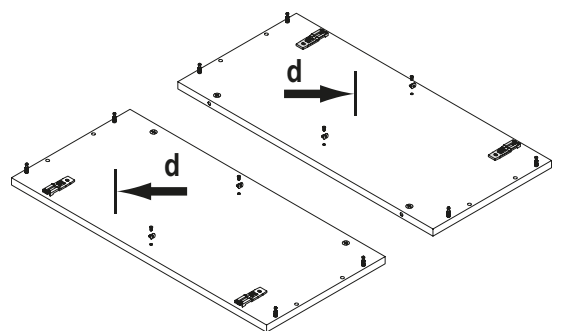

29

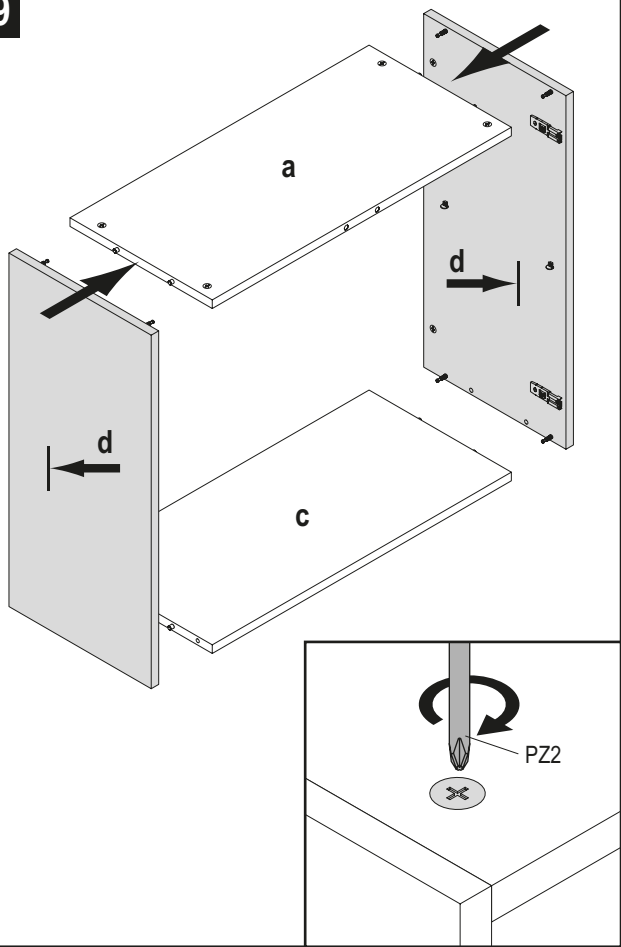

30

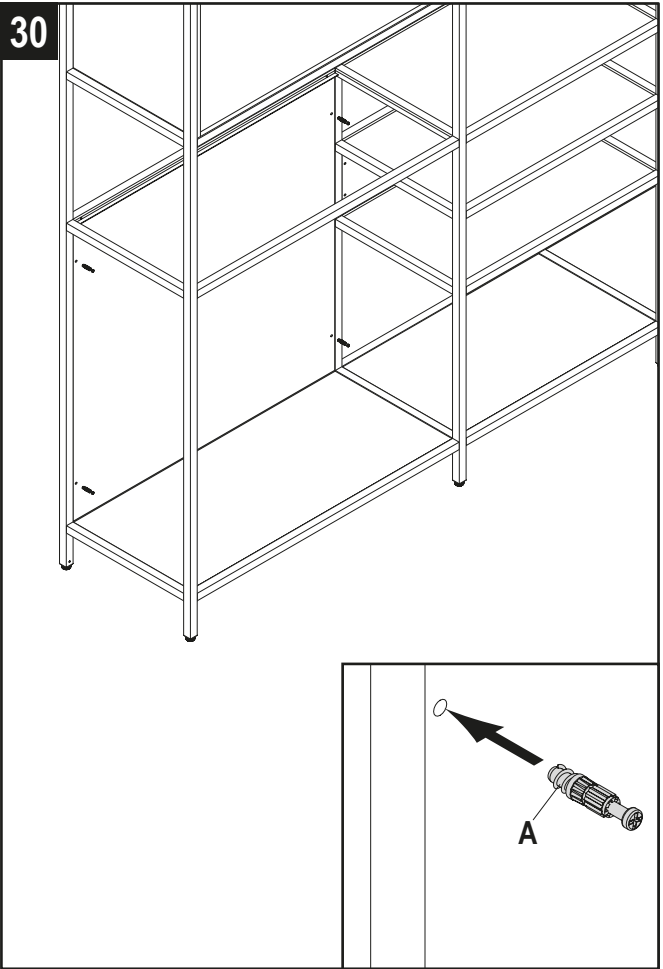

31

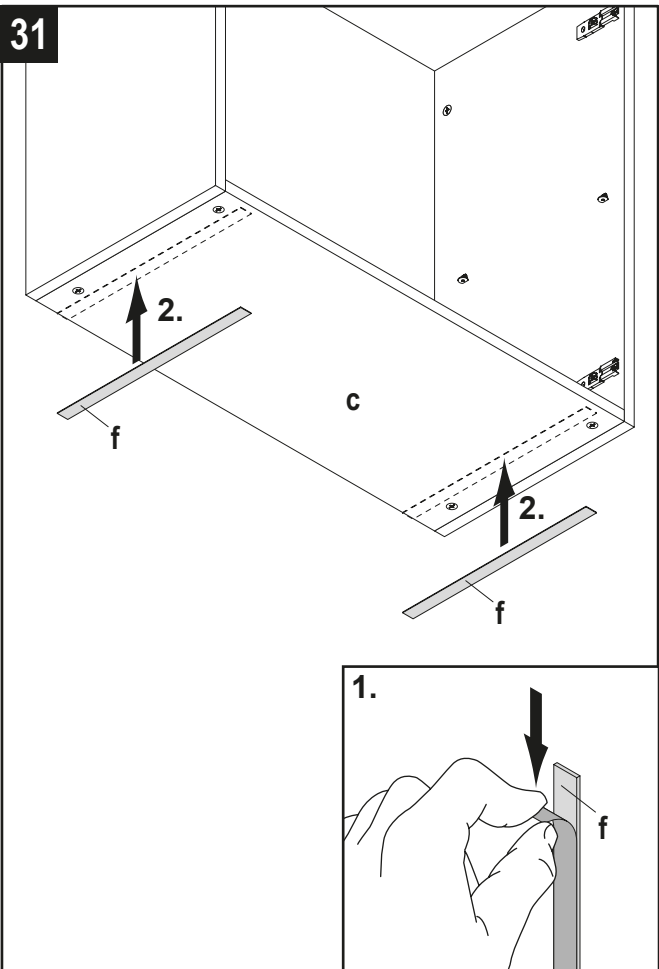

32

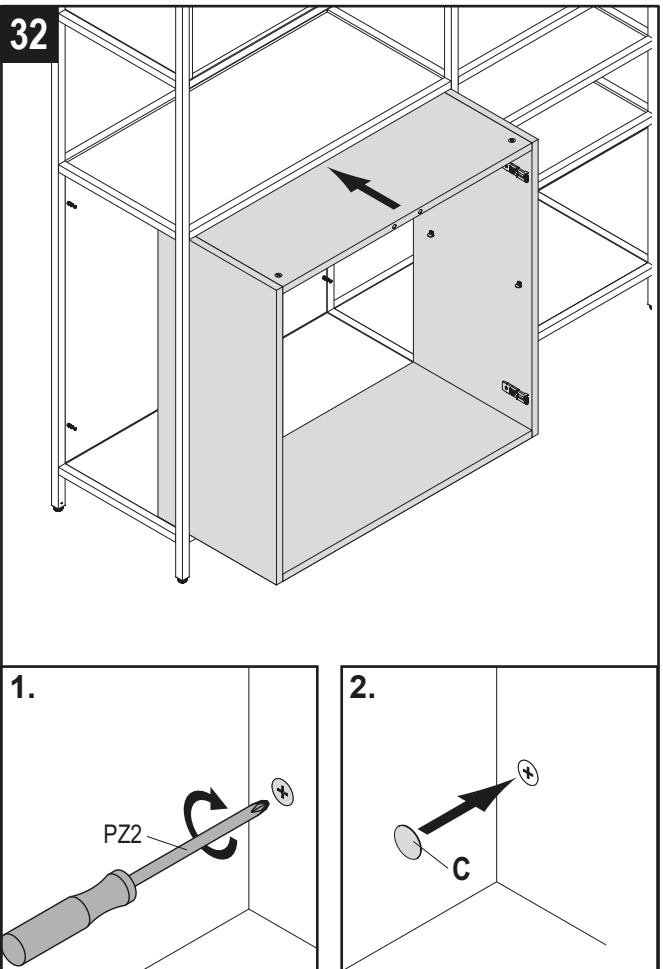

33

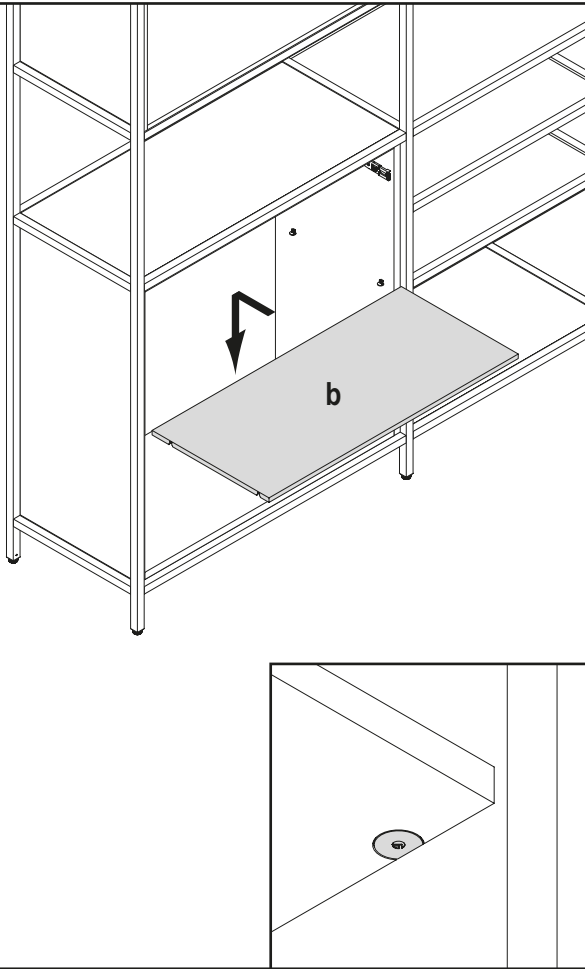

34

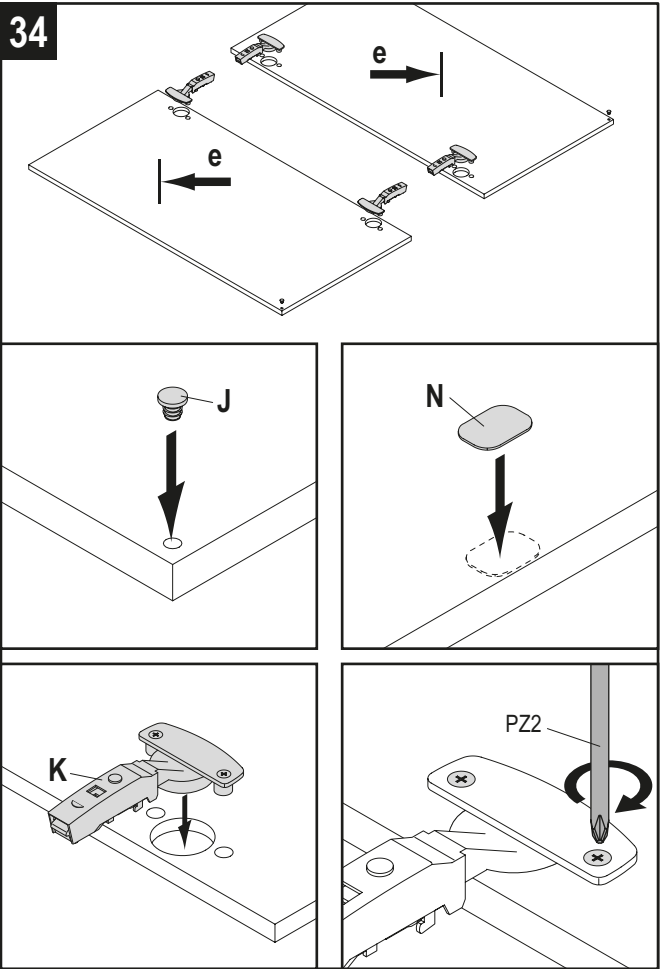

35

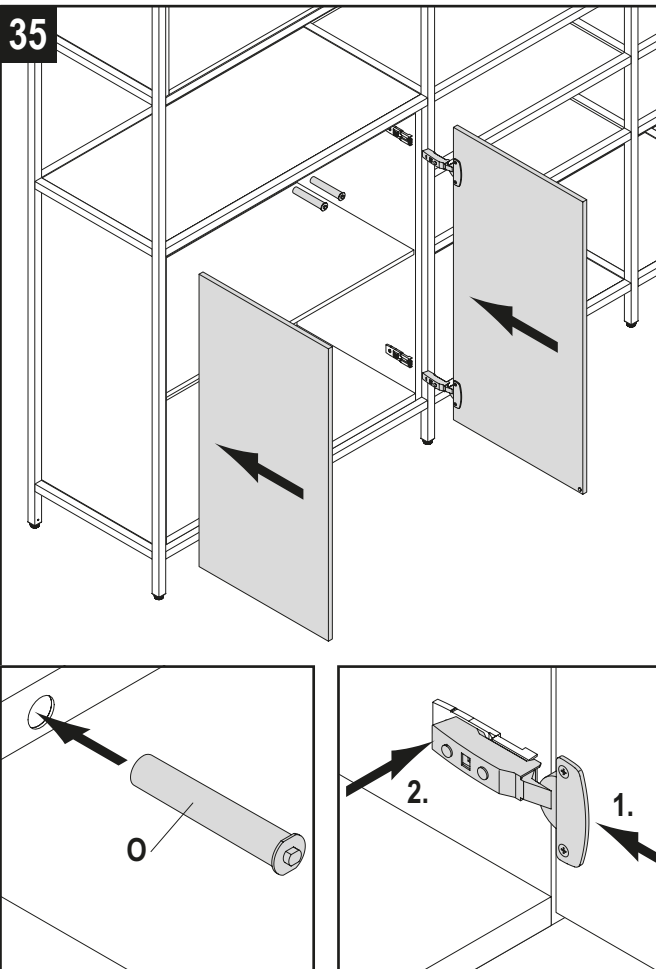

36

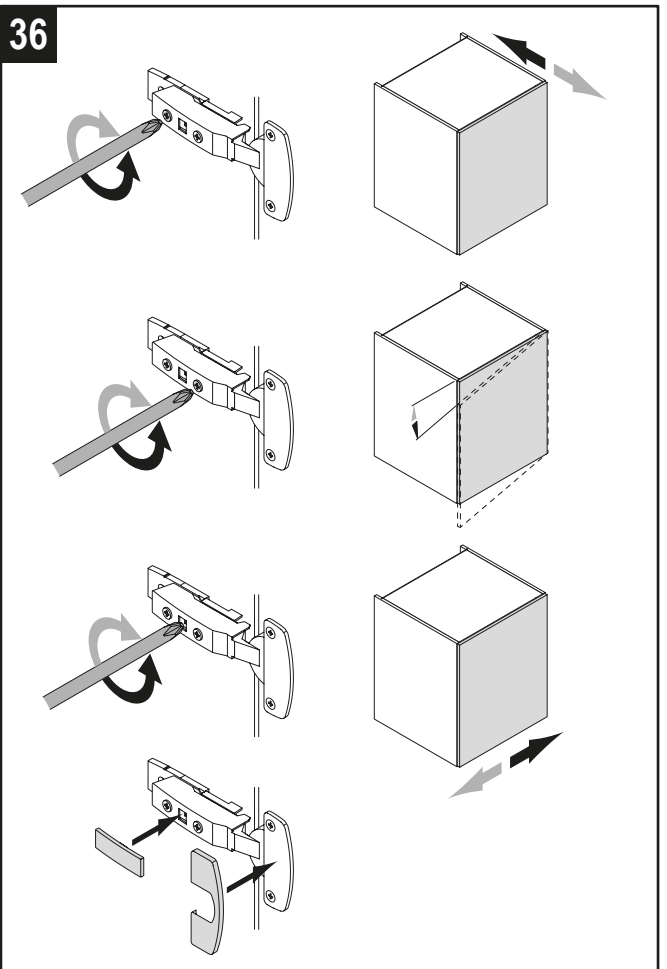



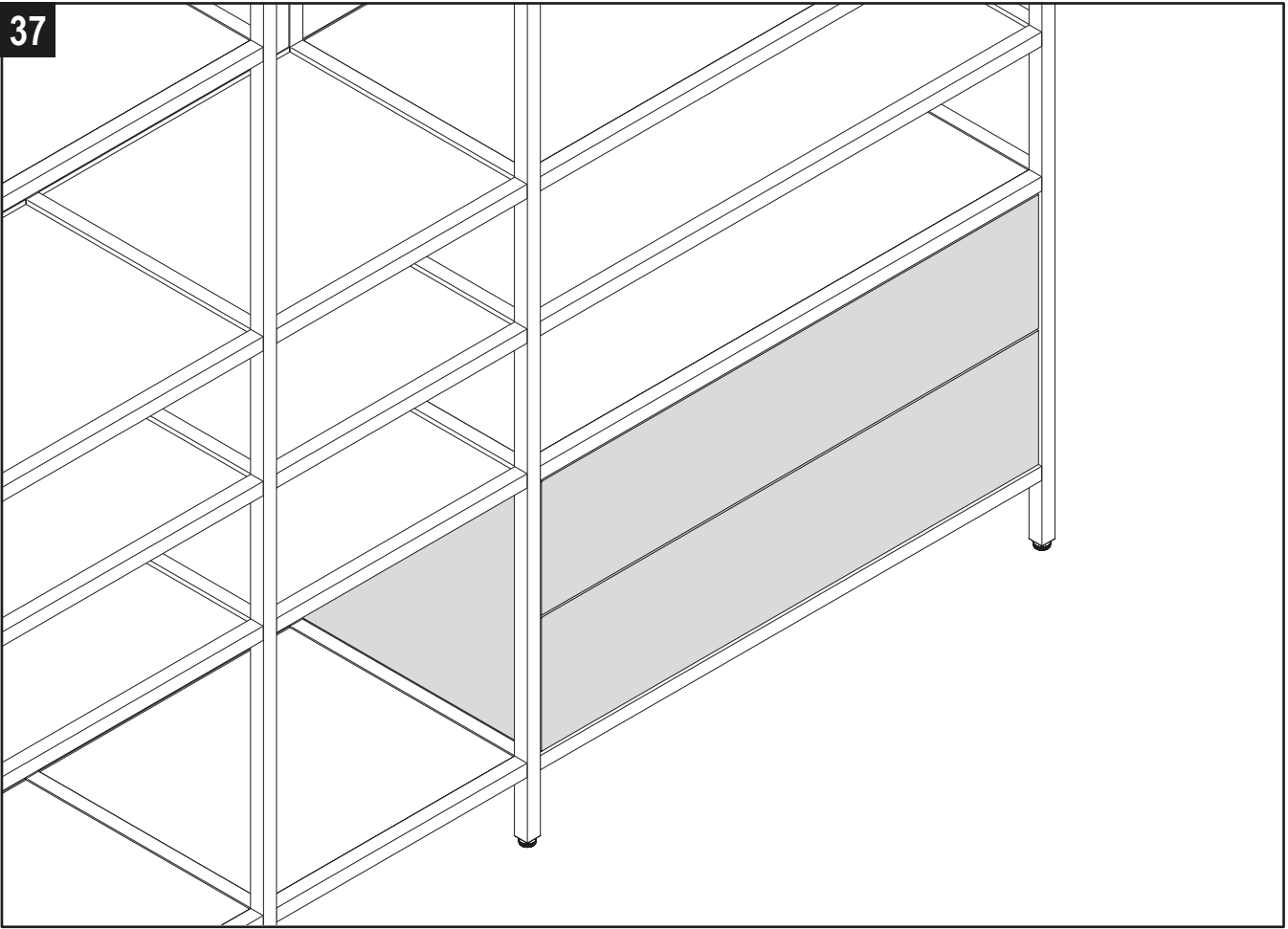

37

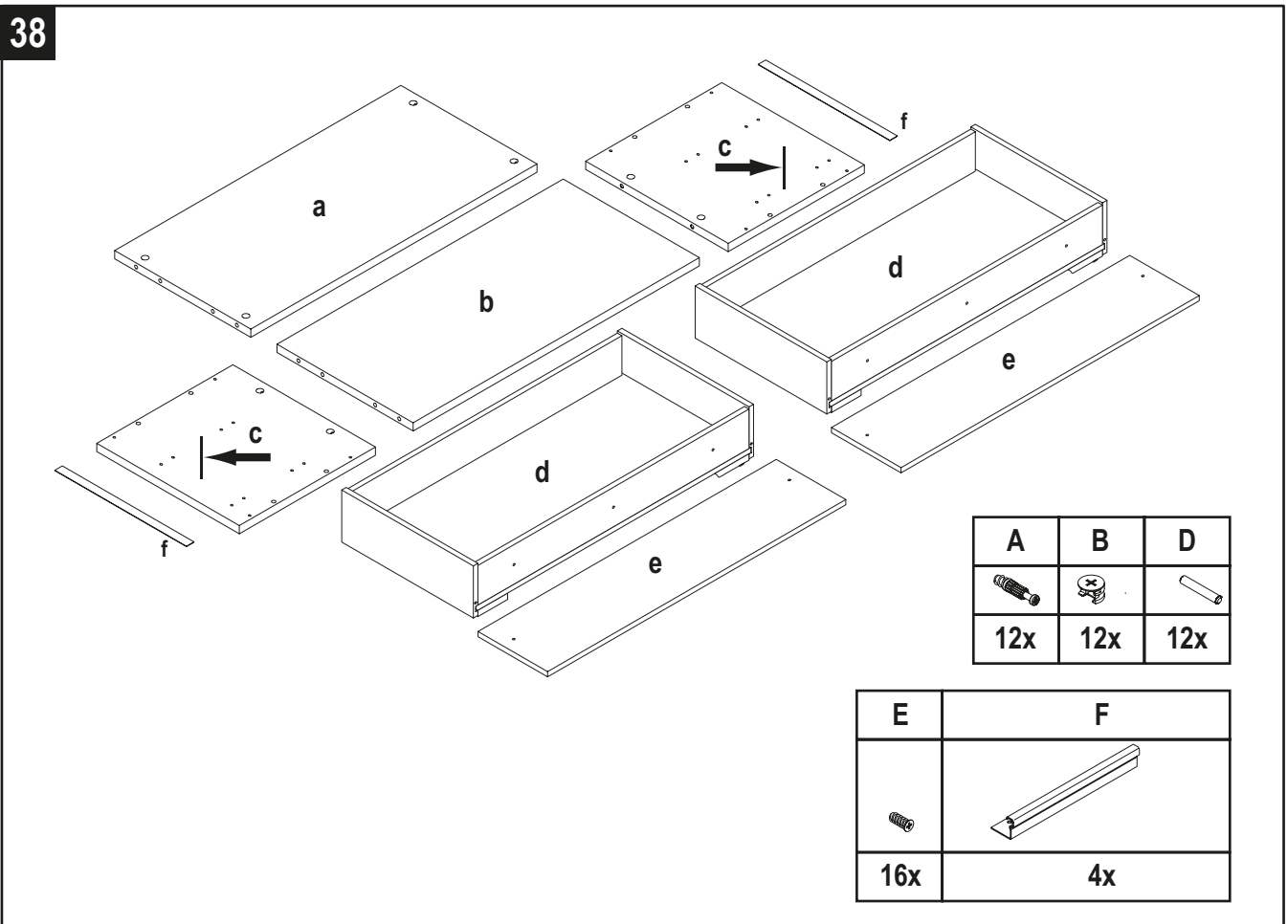

38

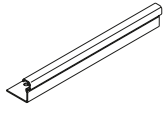

A	B	D
		
12x	12x	12x

E	F
	
16x	4x

39

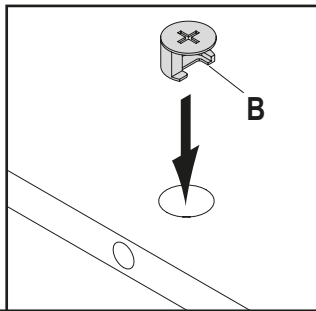
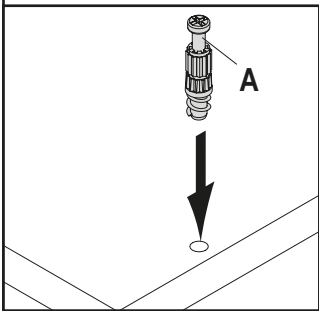
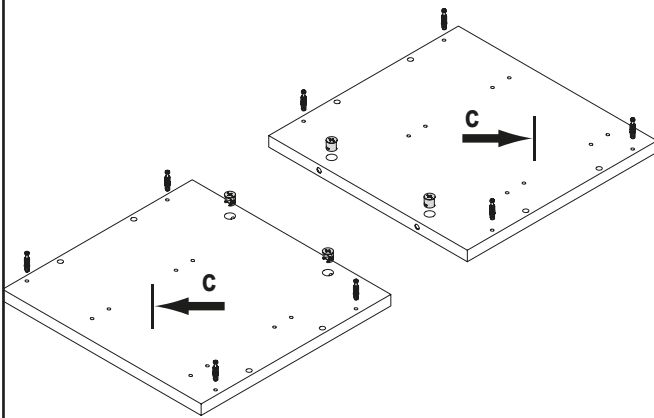

40

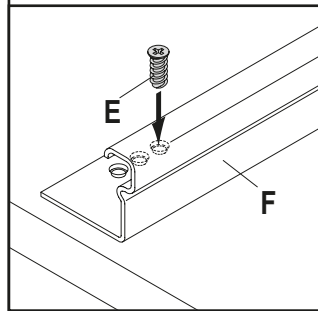
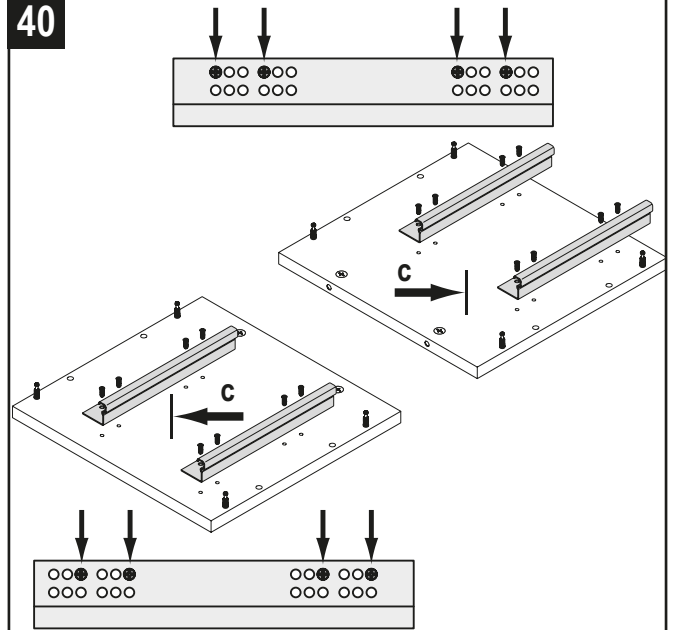

41

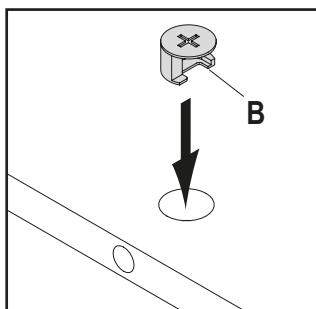
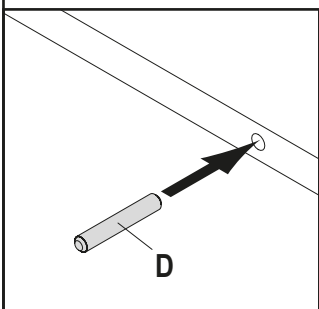
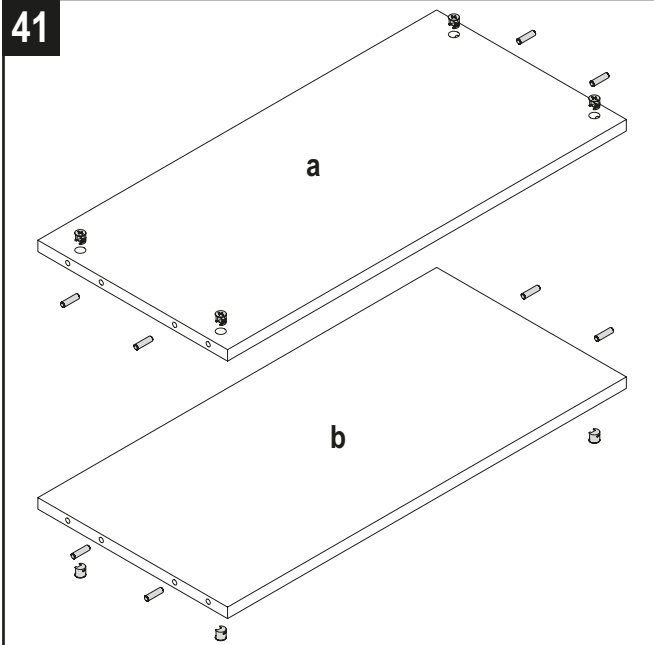

42

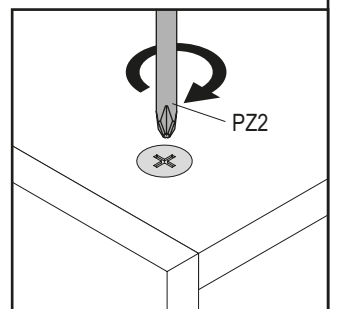
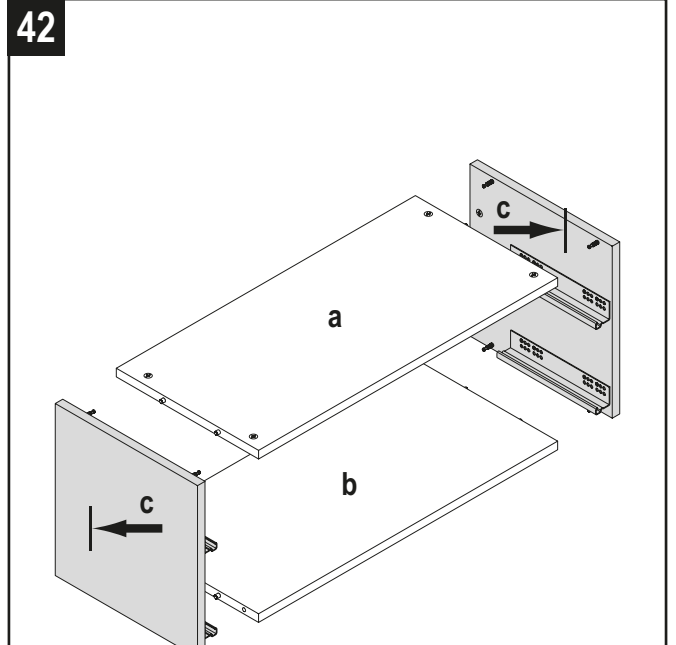

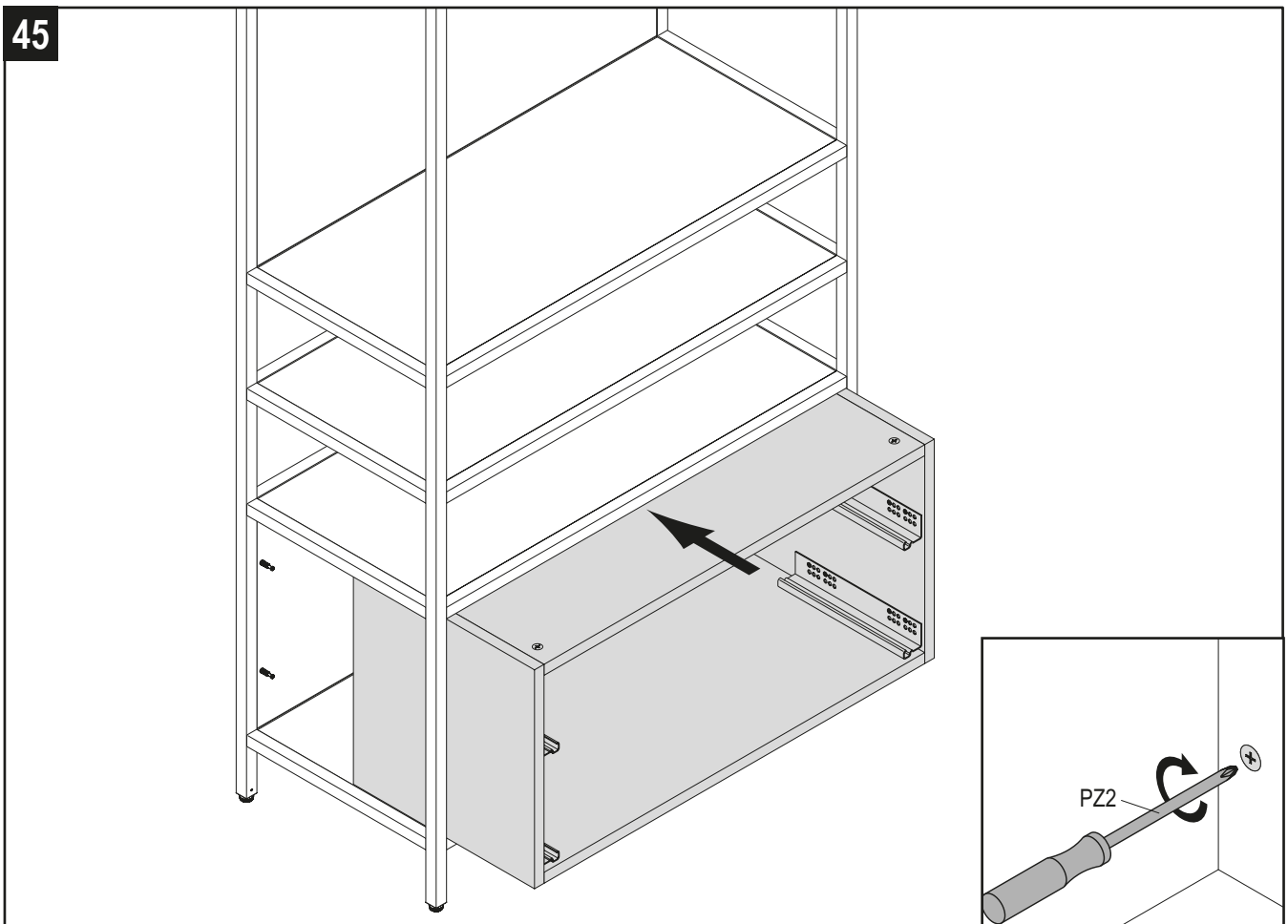
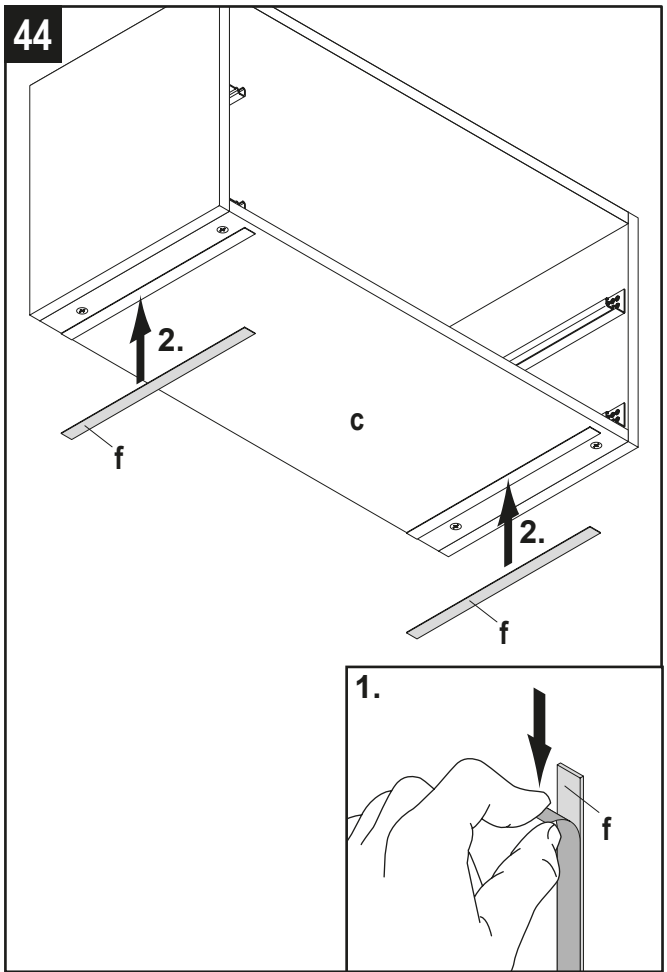
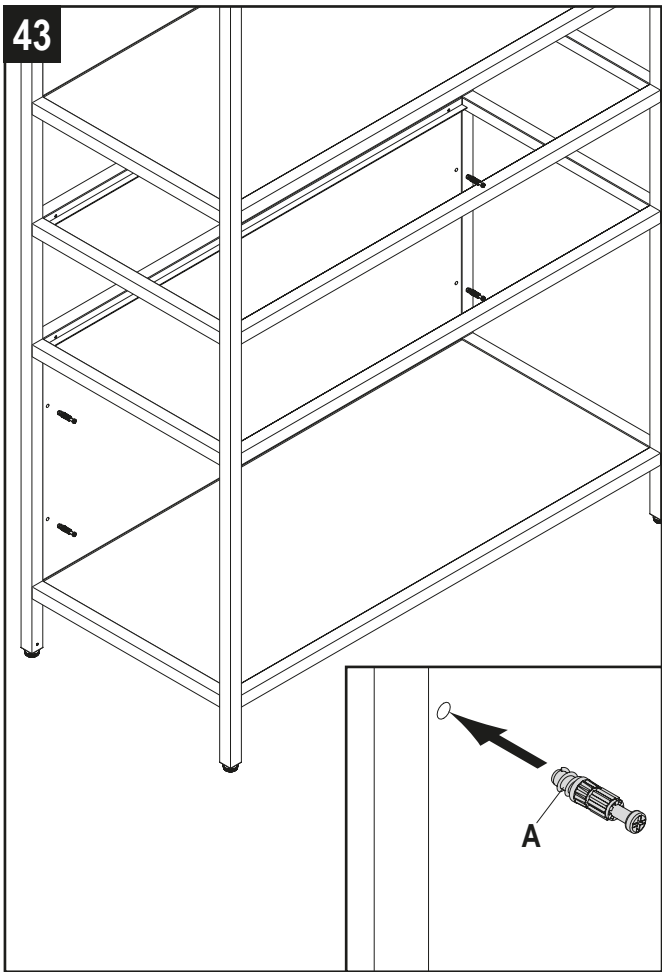

46

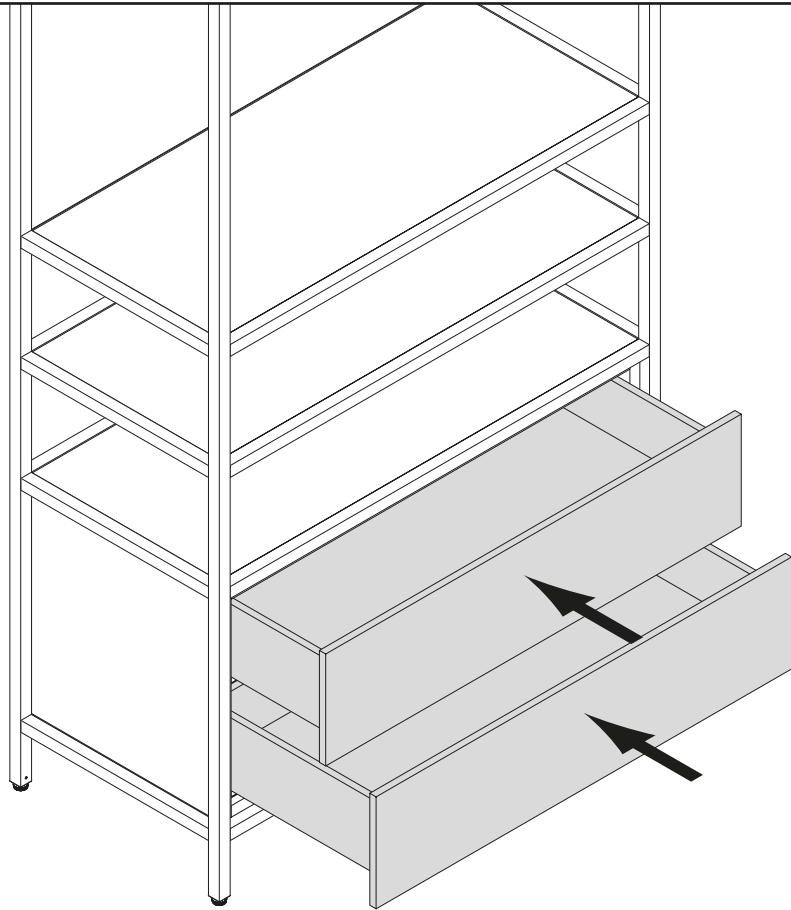

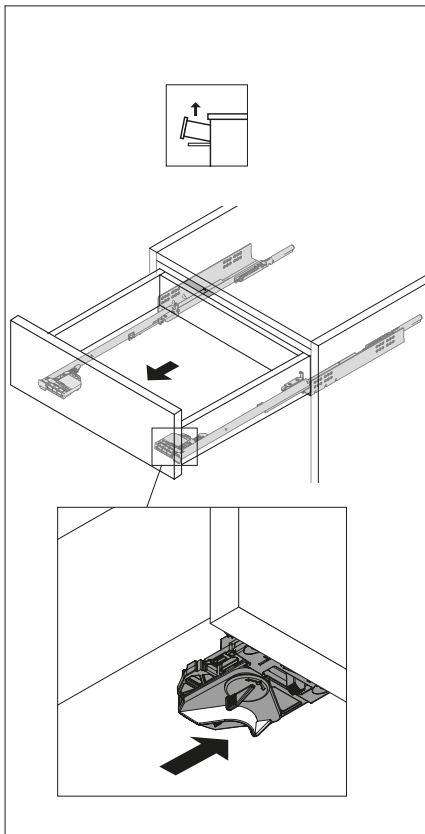

1_

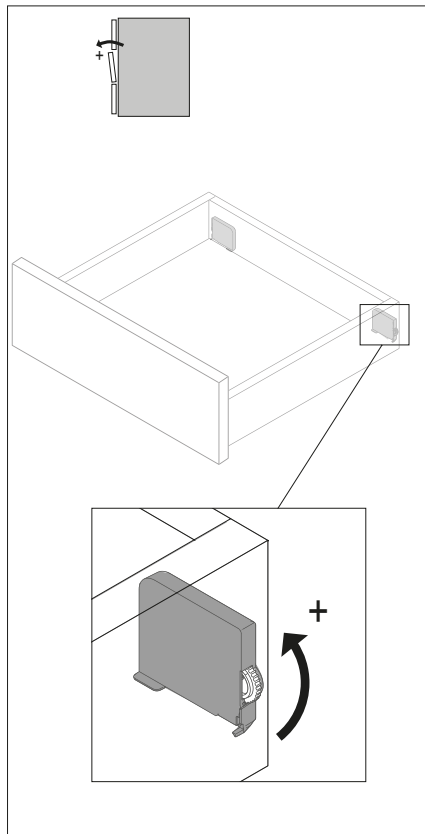

2_

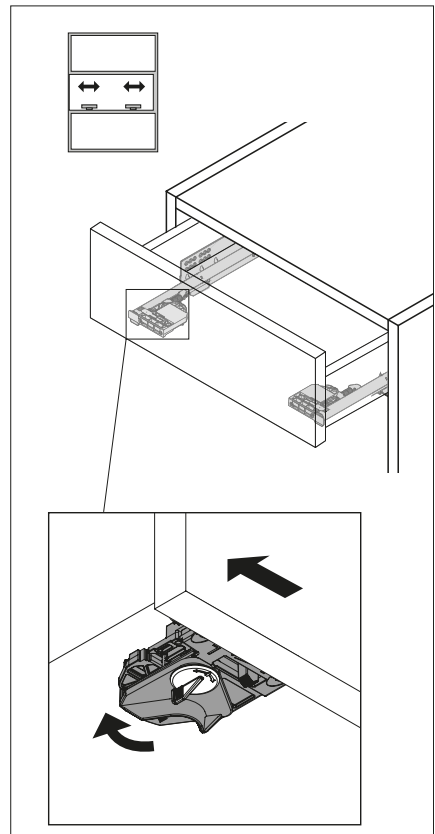

3_

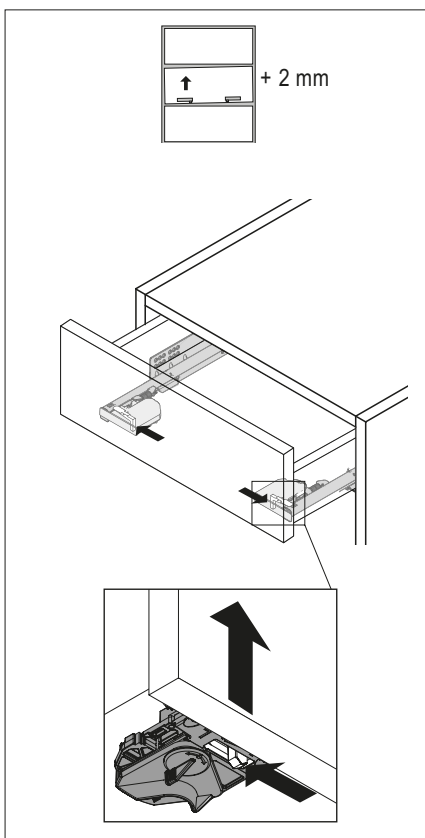

4_

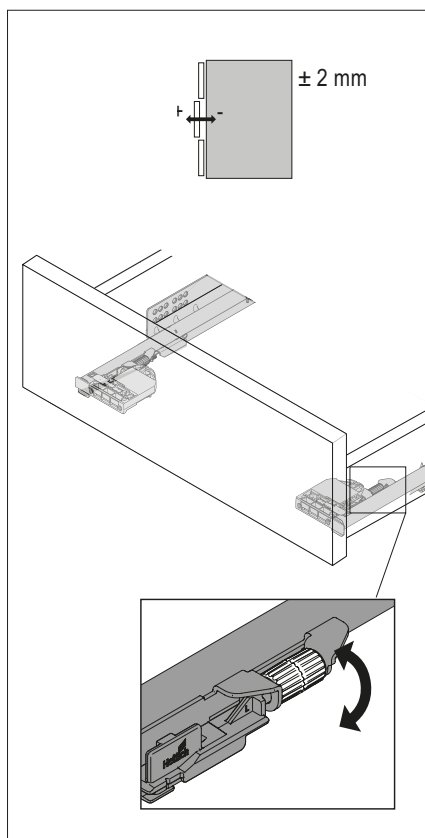

5_

48

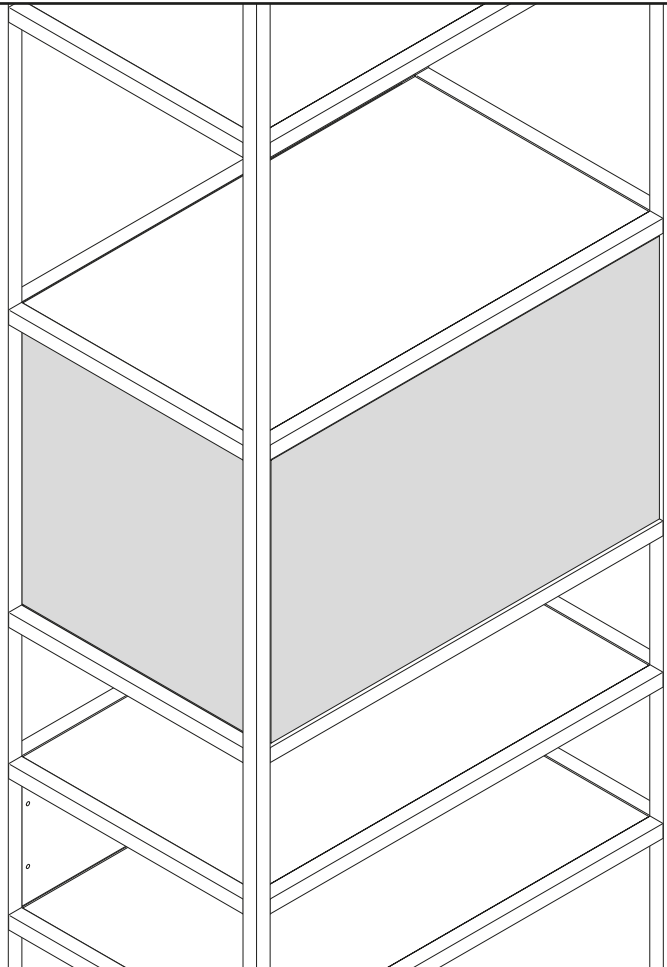

49

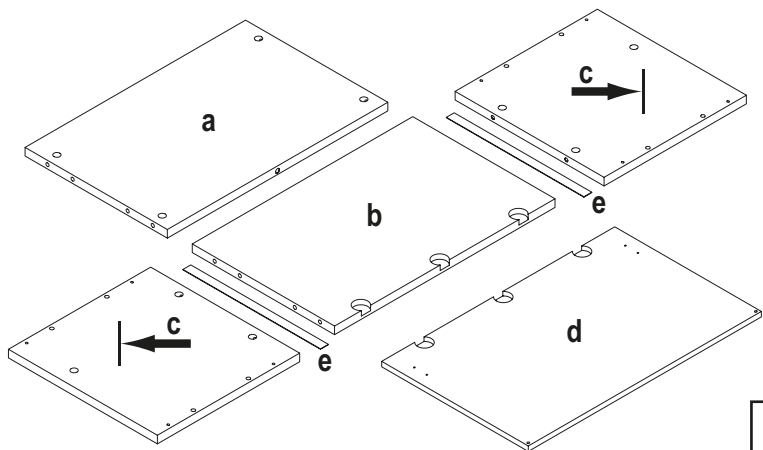

A	B	C	D	E
12x	12x	4x	8x	12x

F	G	H	I	J	K	L	M	N	O	P
3x	3x	3x	4x	2x	2x	2x	2x	1x	2x	3x

50

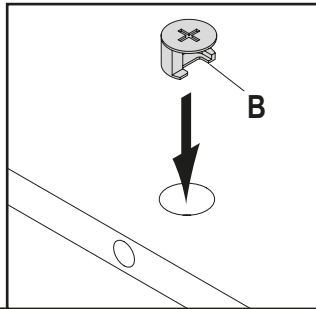
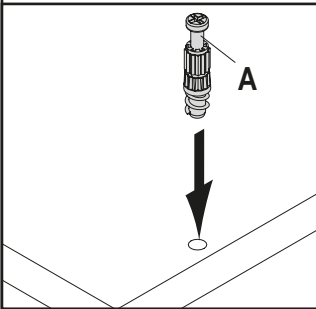
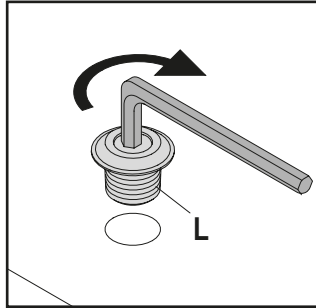
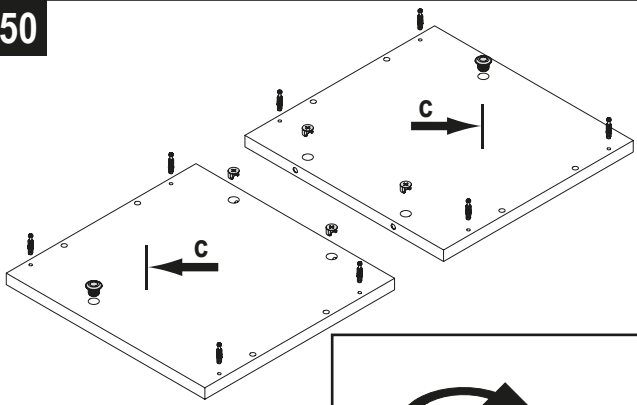

51

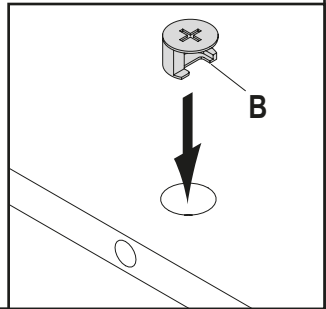
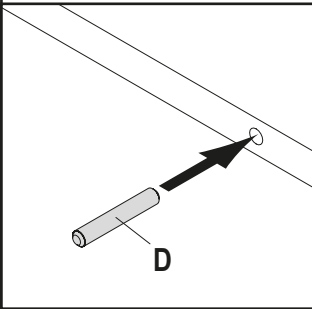
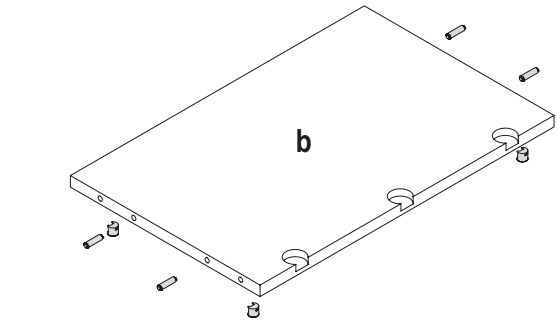
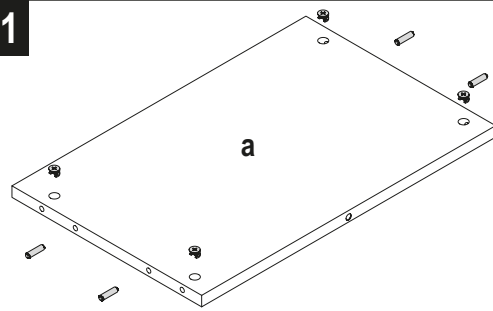

52

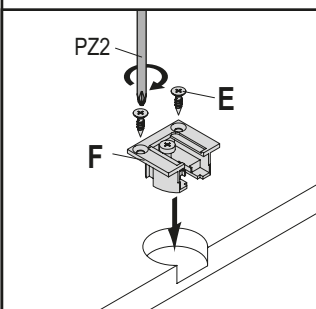
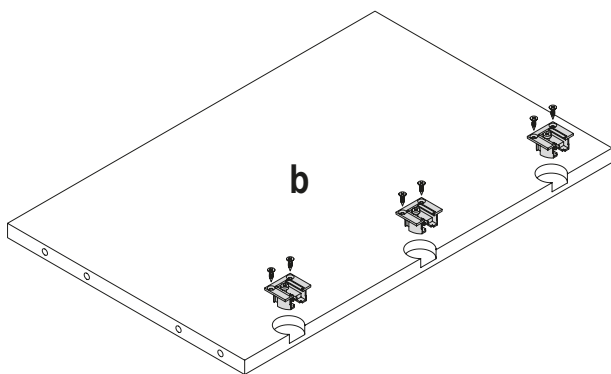

53

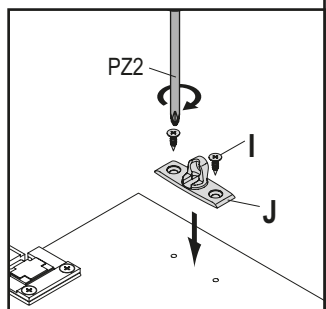
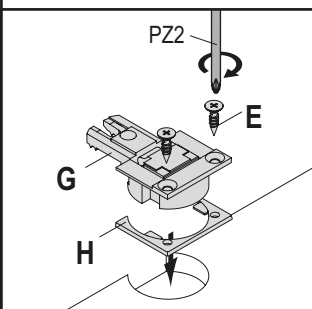
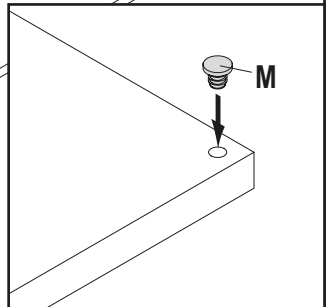
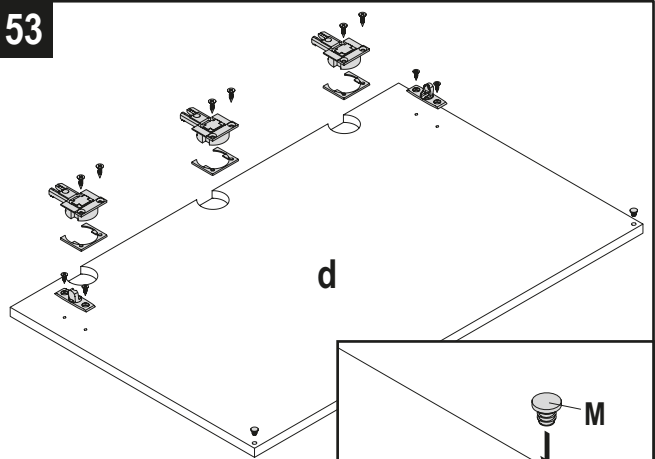

54

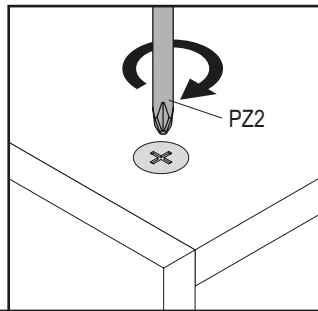
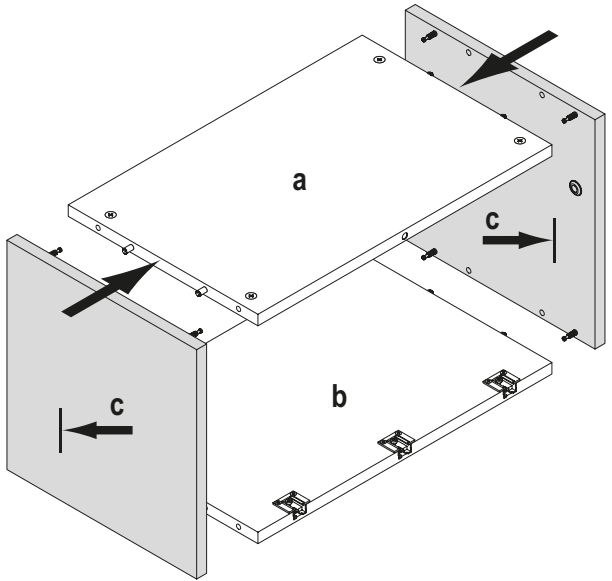

55

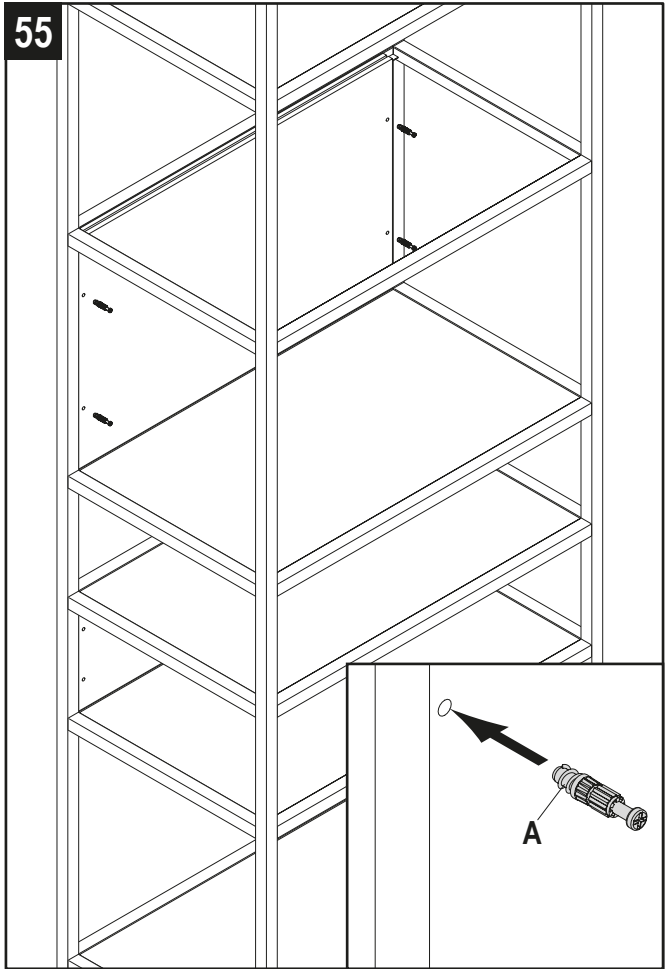

56

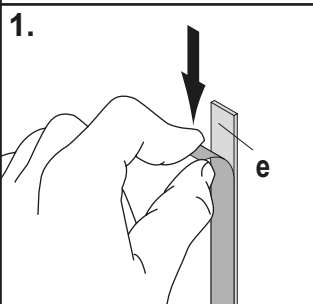
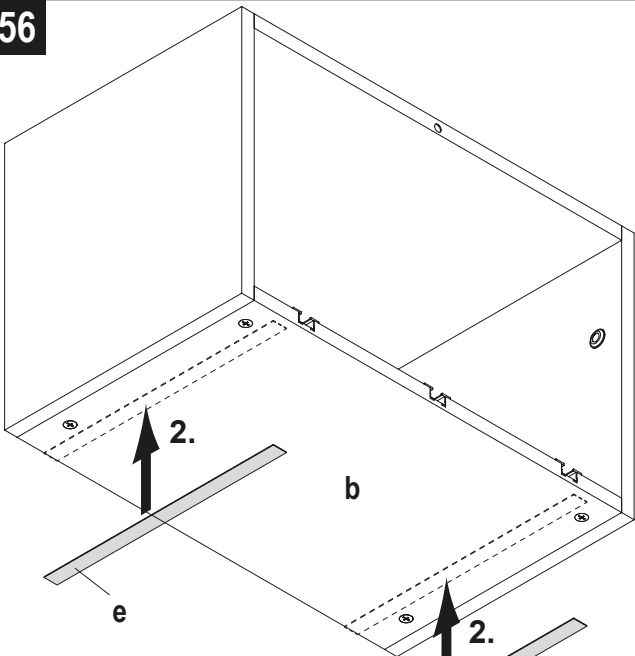

57

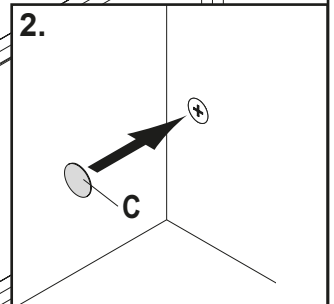
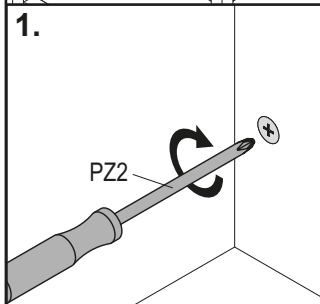
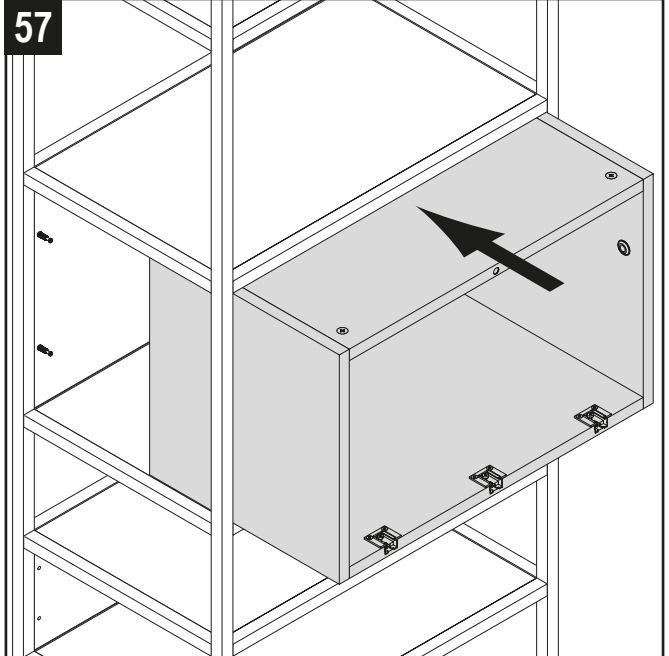

58

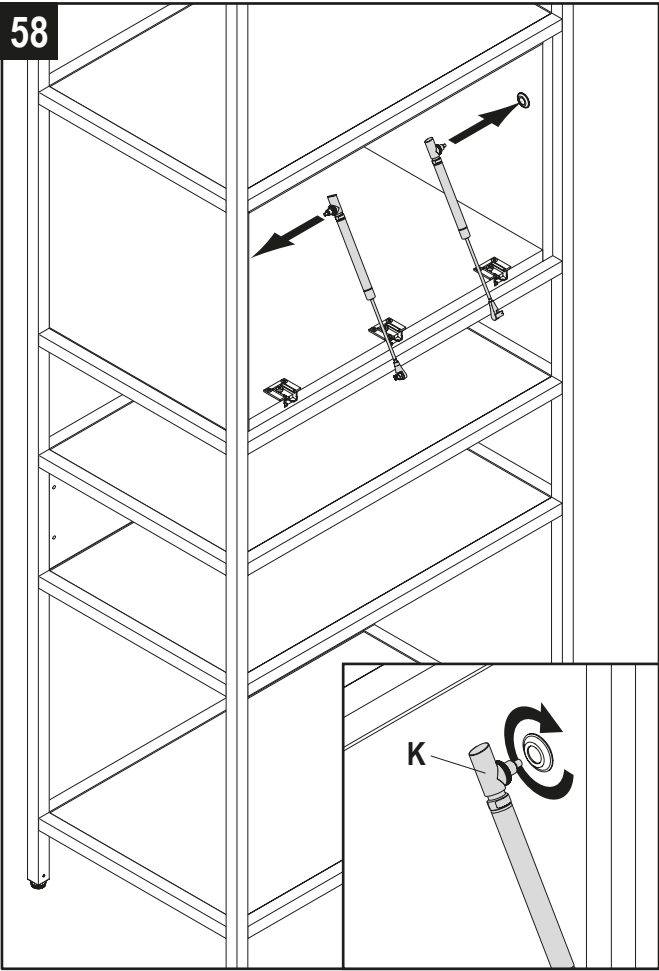

59

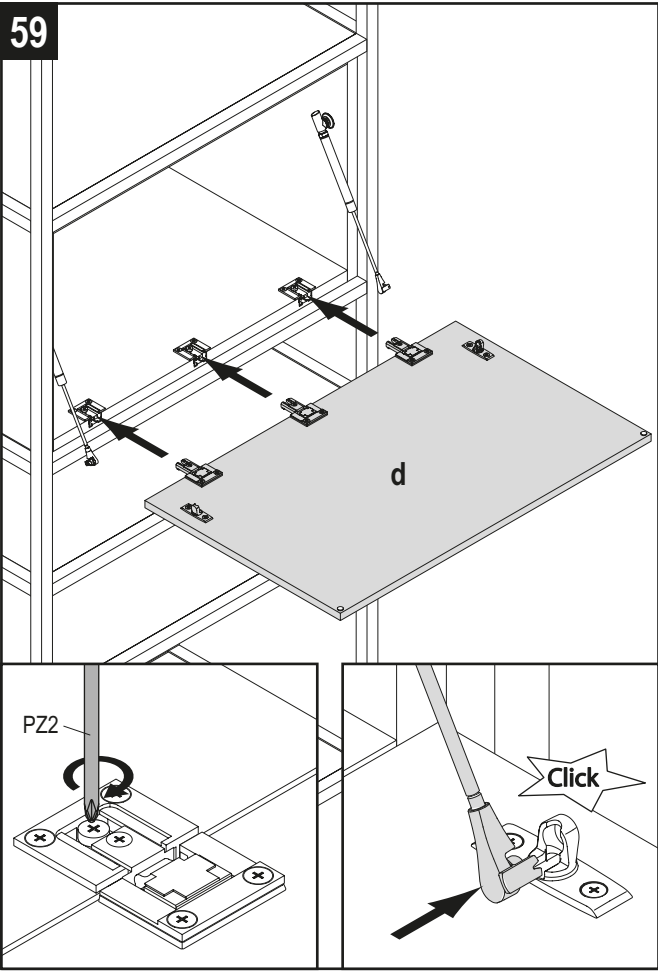

60

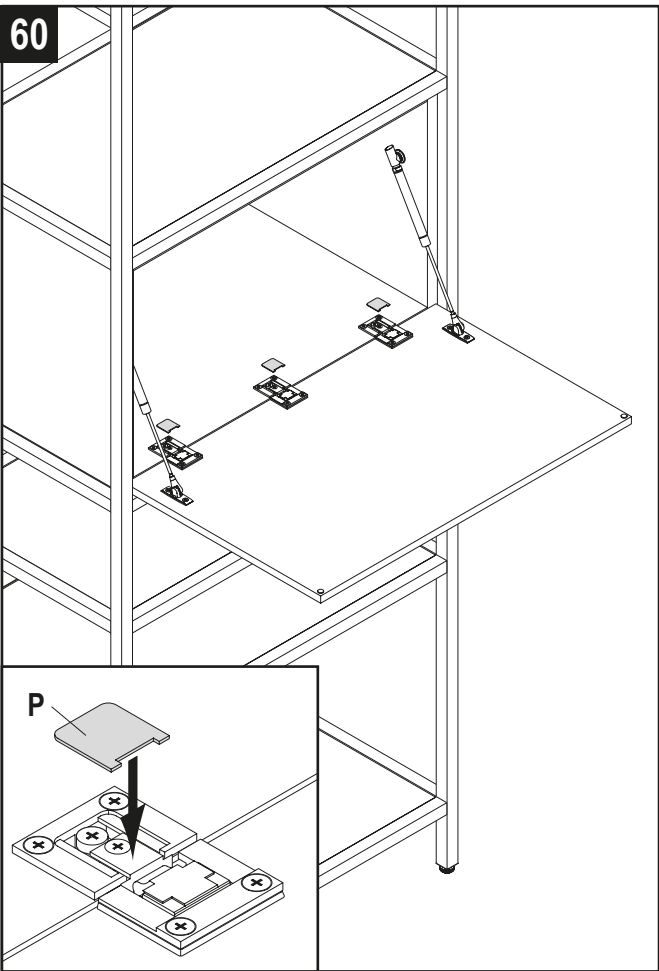

61

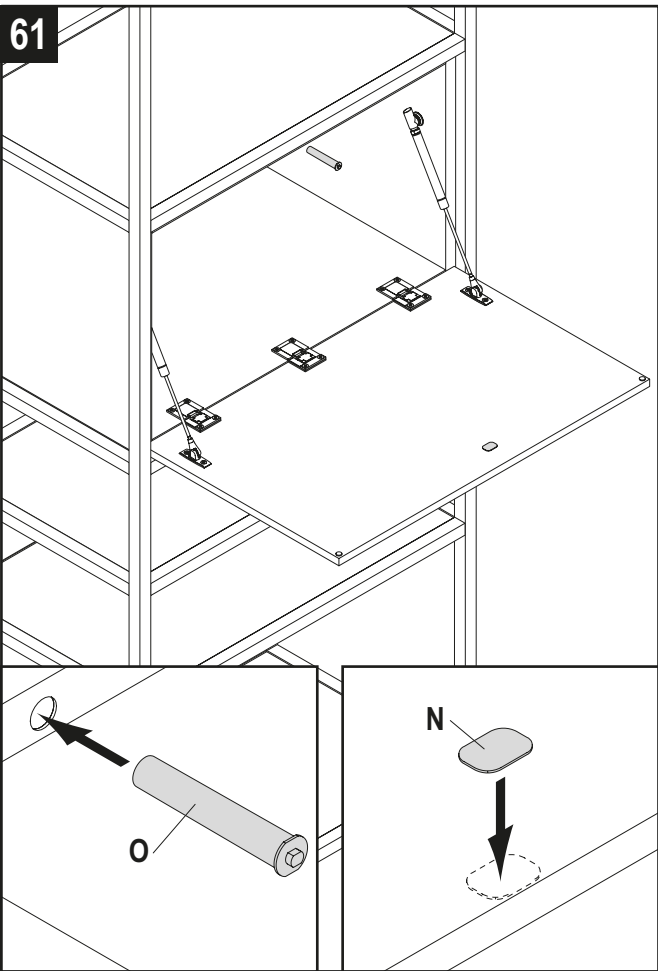

62

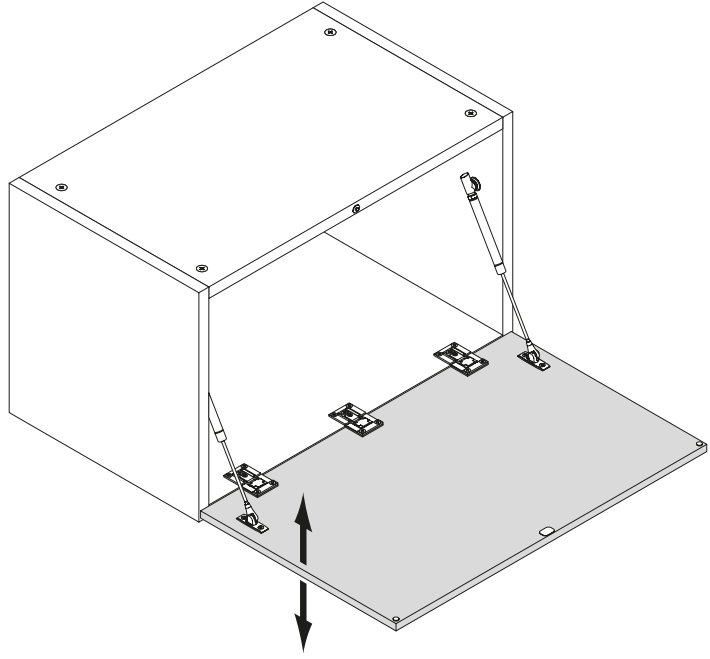
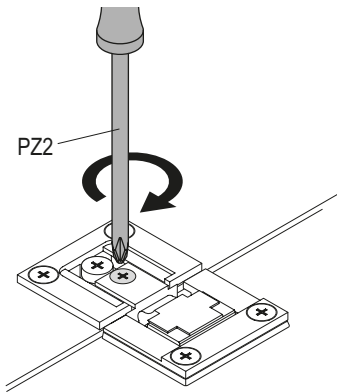

63

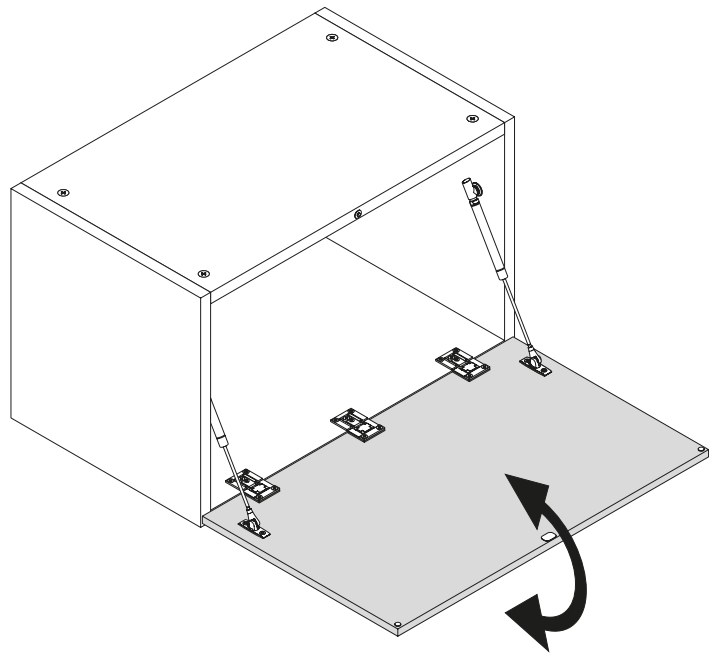
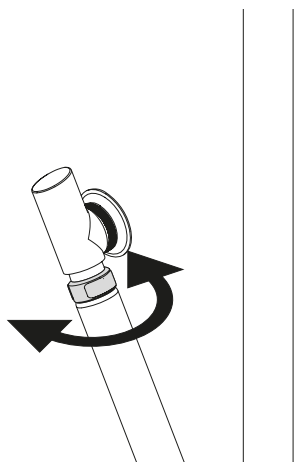

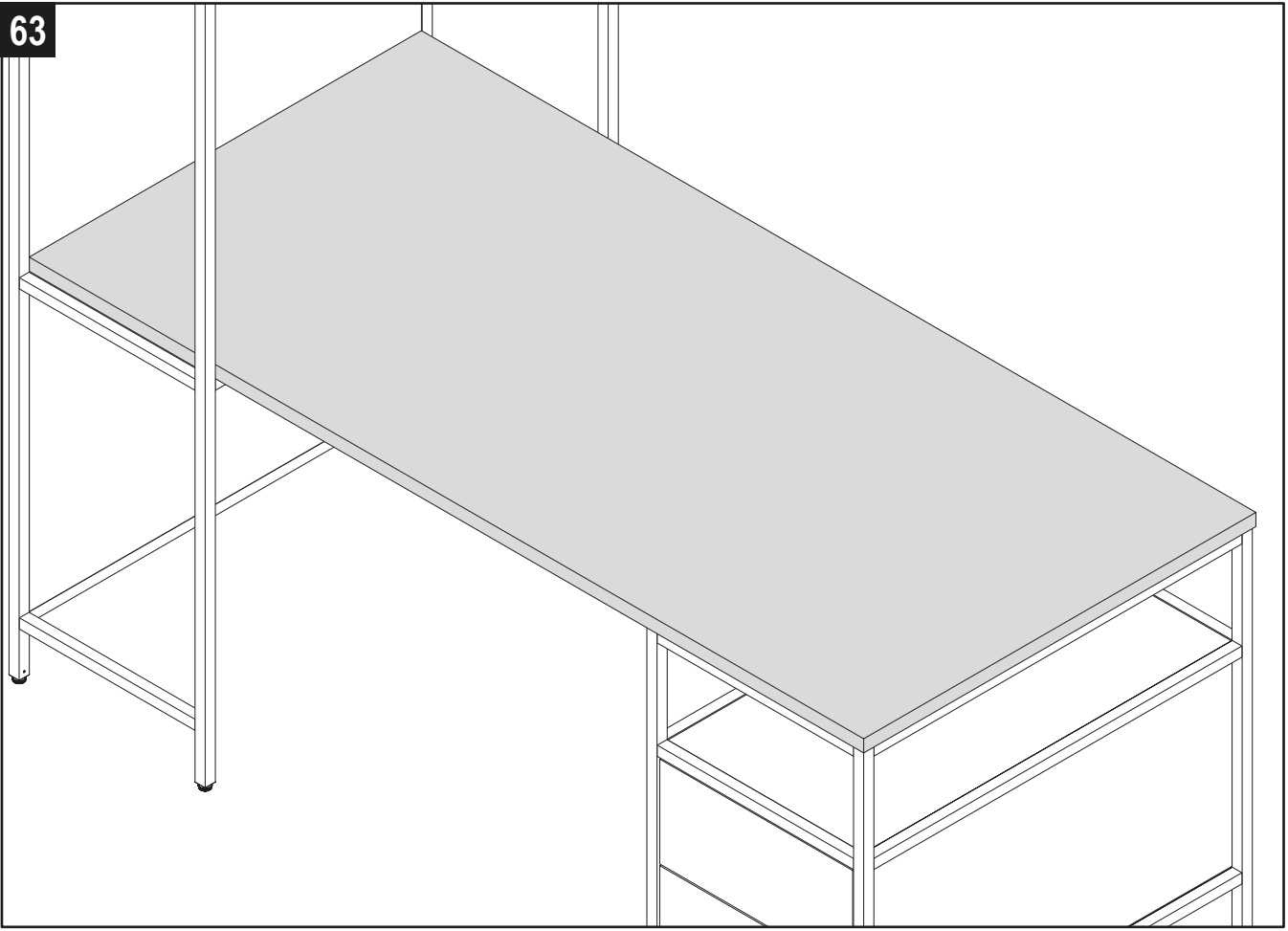

63

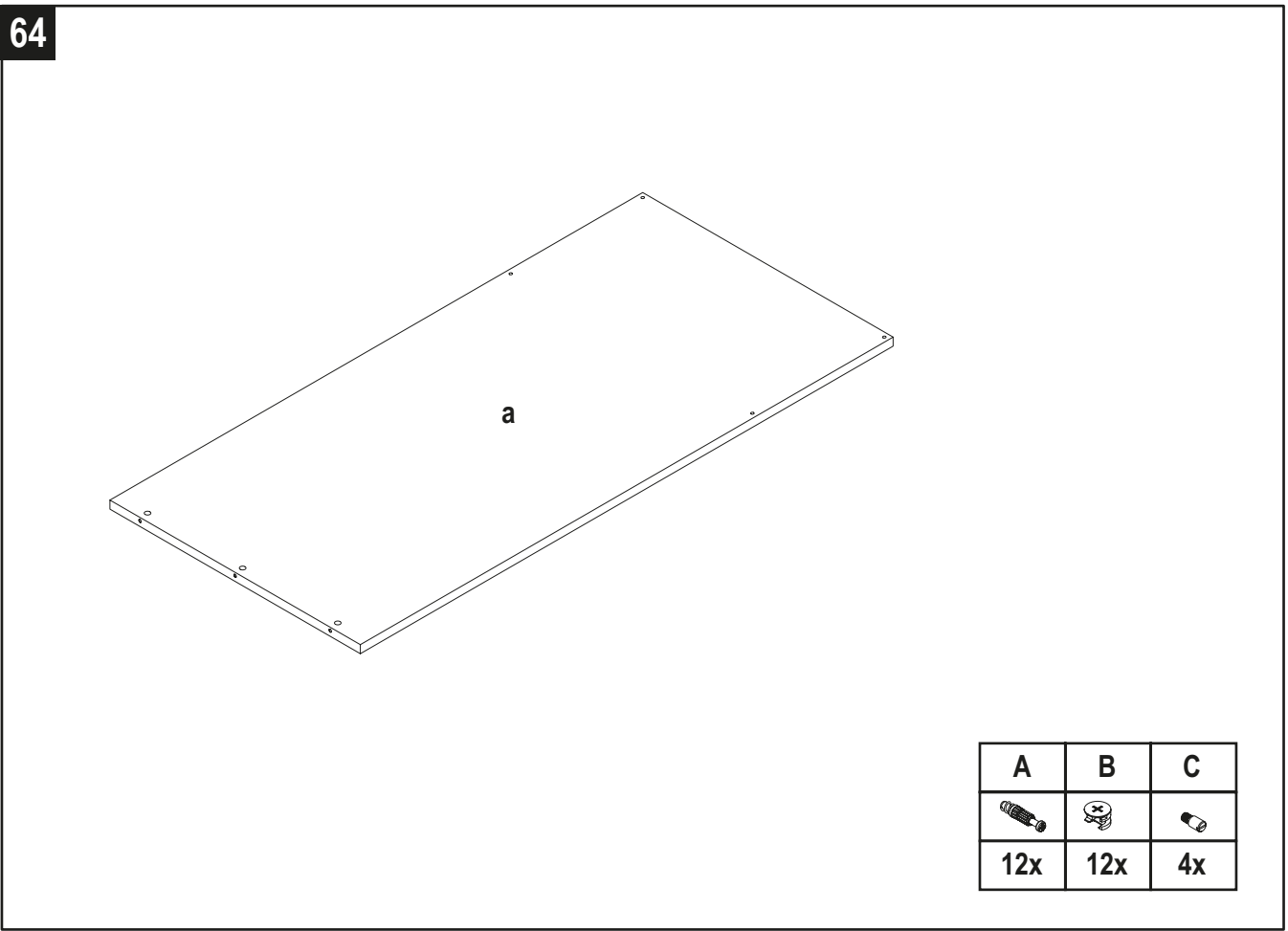

64



A	B	C
		
12x	12x	4x

65

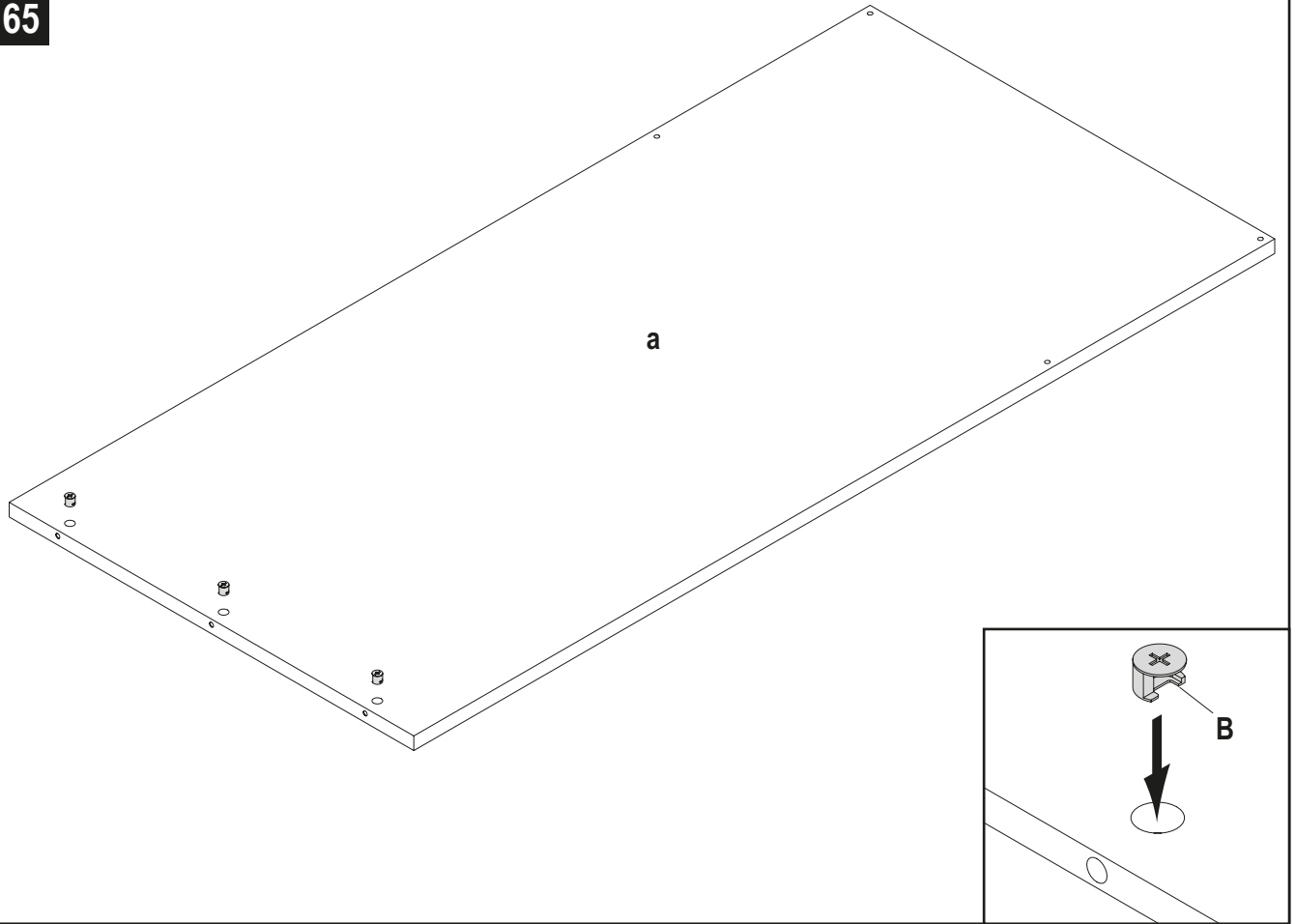

66

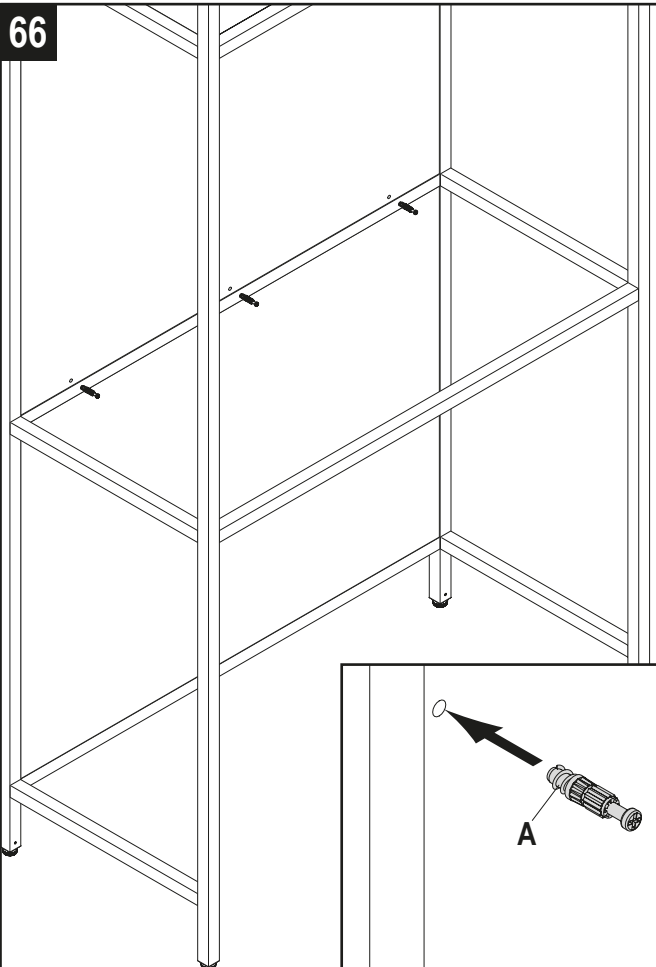

67

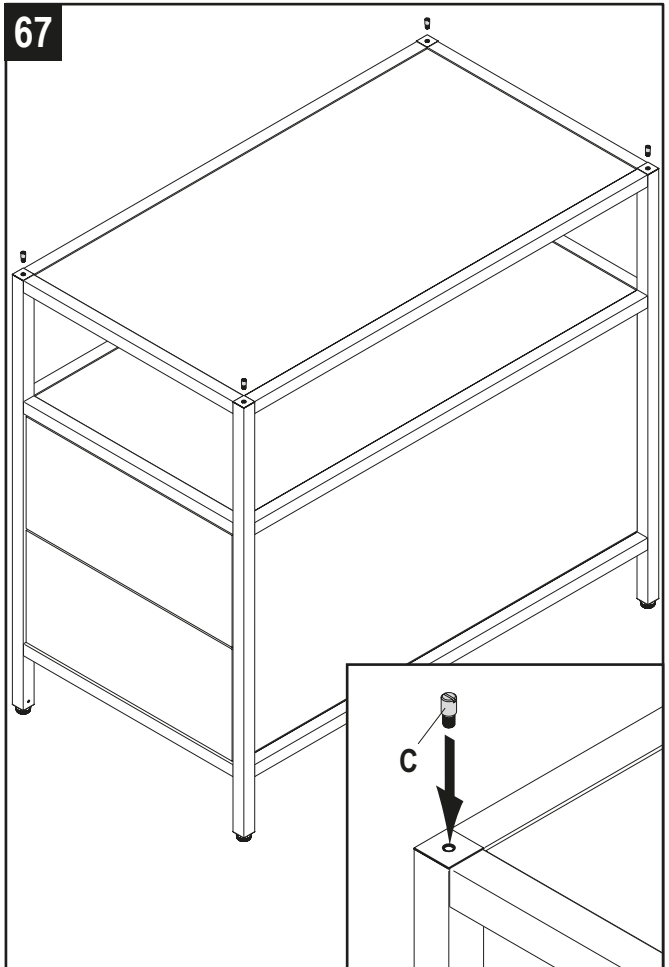

68

