

SLIDING DOOR: ASSEMBLY INSTRUCTION

SYSTEM AIR-B / SERIES 8000

DIVIDING RAIL AND HANDLE

Version 1.0 (2016-08-10)

1.02.1.c



Subject to technical changes.

raumplus

CONTENT AND TOOLS

CONTENT::

Content and tools	page	02
Product information	page	03
Manual	page	05
Accessories	page	06
Detail drawing dividing rail	page	07
Cutting dimension /drilling pattern	page	08
Assembly instruction	page	11
Installation instruction	page	15

ADHESION:

STANDARD		OPTIONAL
TESA	← System →	3 M
Cleaner: 3 M - Surface Cleaner VHB (for both systems)		
Promoter 60150	← adhesive agent →	Primer 94
ACX^{plus} 7044	← adhesive tape →	4613F VHB

TOOLS:

(without claim of completeness)

- Hack saw
- Allen key set
- 2x open-ended spanner (10mm)
- Drilling machine
- Drill set metal / stone
- Screwdriver set
- Rubber mallet
- Pencil
- Water level
- Small pinch roller
- Large pinch roller











VERSION INFORMATION:
Version 1.0: Product launch

PRODUCT INFORMATION

GENERAL INFORMATION: Preparation

- This manual is part of the product and describes the safe and proper installation of the system. Please read the instruction carefully before installation
- Please note that the assembly should only be done by qualified and trained staff in strict compliance with all details indicated in this document. Improper installation in variation from manufacturer's specification may cause defects and danger, thus endangering the safe fixing of the product as well as the safety of the prospective user. The liability of the manufacturer shall be excluded in case of defects and consequential damages resulting from incorrect assembly of this product.
- Please check the completeness of the delivered parts and check carefully if any transport damages are visible.
- If any parts are damaged or lost, please immediately contact the responsible supplier.
- It is assumed that you have exactly identified all cutting dimensions according to the measurement instruction for **raumplus** products.

SYMBOLS:

Symbol	Importance	Symbol	Importance
	Risk or danger		Perform the production step with two persons
	Advice and information		
	Additional information / other documents		
	Directional data / direction of movement		
	„yes“ and „right“		
	„no“ and „wrong“		
	Follow the order		

SYSTEM:

System Information: S 8000 AIR-B

- max. weight of element = **60 kg**
- min./max. door height = **700 mm / 3500 mm**
- min./max. door width = **450 mm / 1200 mm**

PRODUCT INFORMATION

GENERAL INFORMATION: **Product safety**

- The door system complies with the prior of the art and the authorized safety rules at the time of delivery.

USE:

Intended use

- The prerequisite for the intended use of our products is the professional installation according to our installation instruction. Sufficient fittings must be available and durably installed to all relevant places.
The function of the fitting must not be hindered or altered during installation.
- Special solutions are only possible in consultation with **raumplus**.

Use not as intended

- Risk or danger may occur in the following cases:
 - the door system has improperly been installed or maintained
 - the safety and installation instructions have not been followed.
 - after improper installation or inadequate fixing (e.g. to parts of buildings)
 - the maximum weight of the doors has been exceeded.
 - improper shock and case loads or other additional loads on the fittings have occurred
 - the fittings have been used outside.
 - body parts or objects got in to the closing edges or door runnings during use of the door wing.
 - the door system is not used as intended.

Structural modifications

- Structural modifications that are not offered as an accessory from **raumplus** may only be attached or installed with permission of **raumplus** GmbH!

MANUAL

This manual is part of the delivered product and describes the safe and proper use.

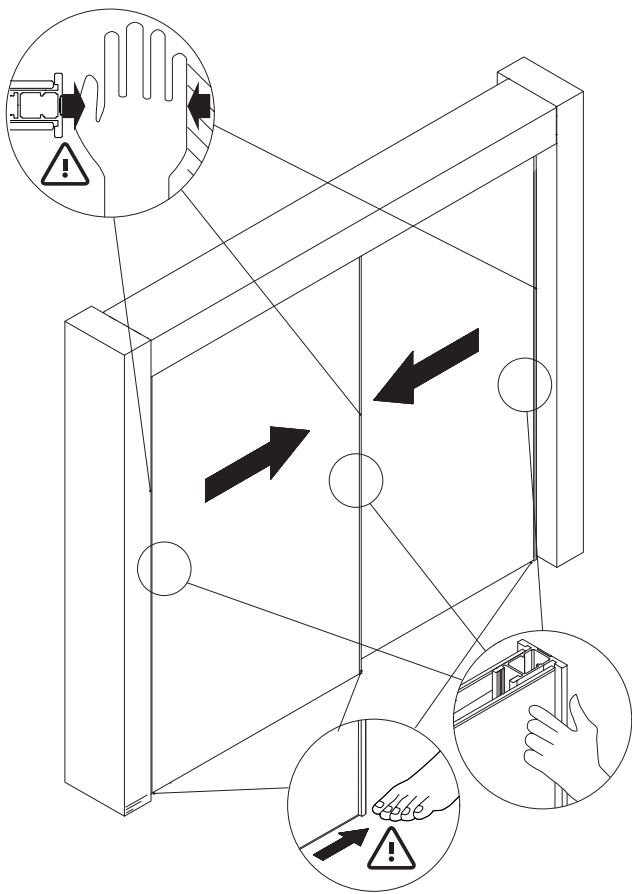

Designated use:

The product is designed and manufactured for indoor use.

The product was designed as a hand-guided sliding door that is usually not being moved faster than walking speed and should be stopped manually when reaching the end position. The doors are guided on top track.

Any other use that deviates from the specific proper use is not according to the **raumplus** regulations.

Manual:

Open the door by the handle profile or the handle (optional).

Guide the door slowly to the ...
... opening / closing point.

Attention:

Preserve your hands from getting trapped during the movement of the door. When closing or opening the door never grasp the profile, only use the handle profile or the handle.

Use the door as instructed.

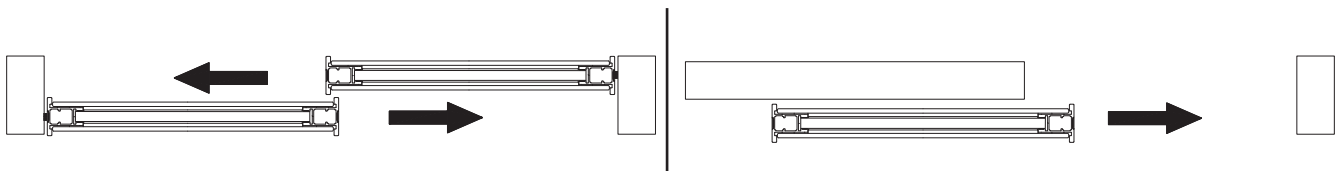

Safety Information:

The product complies with the prior art and the recognized safety rules at the time of delivery.

- Pay attention to child safety.
- No additional load to the doors.
- Structural changes, additions or modifications can only be carried out by a dealer.
- In case of malfunctions or irregularities: shut down the system and contact your dealer.
-  For Installation without wall connection: use of stopper is obligatory!

As defined in the „Law of Liability for Products“ (§4 Prod-HaftG), for the liability of the manufacturer, for his products, the above information has to be regarded. The disregard of this manual, releases the manufacturer from his liability.

ACCESSORIES

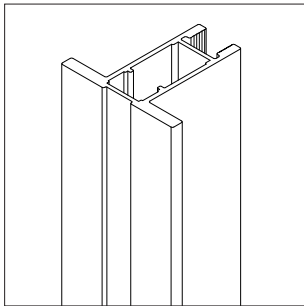

1_ 12.51.02x

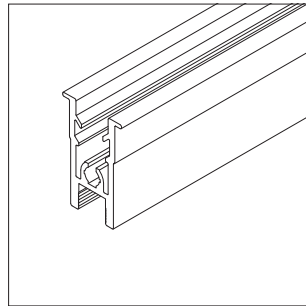

2_ 19.34.0xx

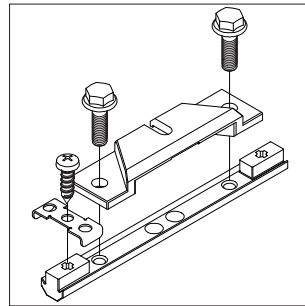

3_ 10.06.021

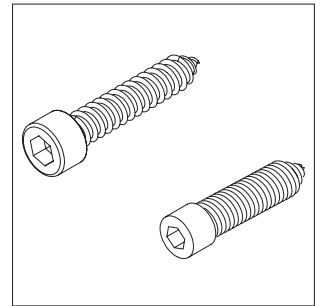

4_ 10.07.012 / 10.07.008

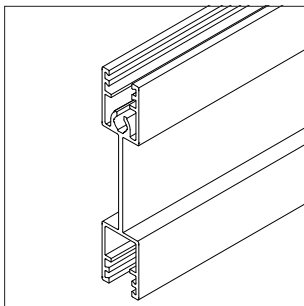

5_ 19.22.0xx

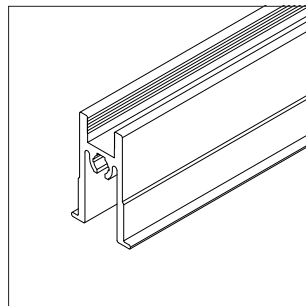

6_ 19.36.0xx

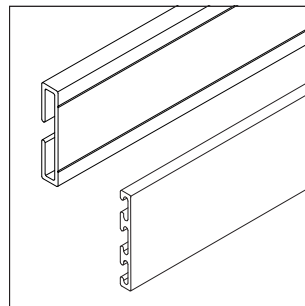

7_ 19.23.0xx / 19.24.0xx

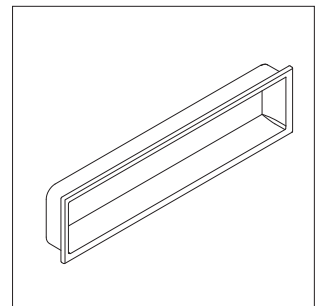

8_ 10.01.28x

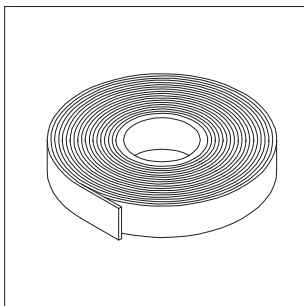

9_ 25.12.047

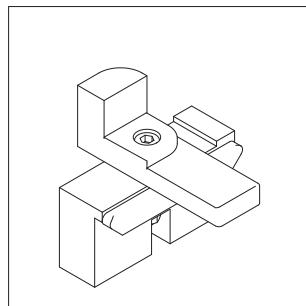

10_ 30.03.012 / 30.03.013

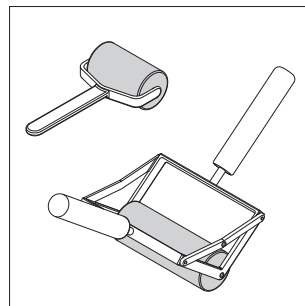

11_ 30.15.025 / 30.15.026

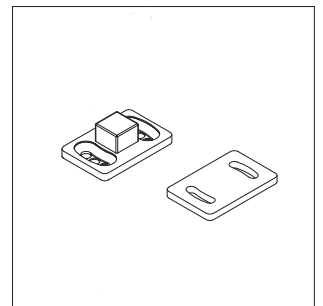

12_ 10.05.047 / 10.05.048

1_ Stile S 8000

2_ Rail S800 air system

3_ Pick-up element S 800 „AIR system“

4_ Frame screws 6,3x32 mm /
screw for dividing rail

5_ Dividing rail S 800

6_ Bottom rail S 800 AIR / C 42

7_ Insert profile for dividing rail S 800
Cover for dividing rail S 800

8_ Handle S800 / C 42

9_ Double side tape S 800

10_ Assembly tool S 800 for anodized profiles /
Assembly tool S 800 for powder coated profiles

11_ Pressure roller S 800 for double sided tape /
Pressure roller S 800 for glass

12_ bottom guiding 12 mm AIR / distance plate for guiding

without illustration:

13_ 8 mm gasket (10.07.034)

14_ handle square 40 x 115 mm (10.01.093)

DETAIL DRAWING

EXPLODED DRAWING SYSTEM S 800 AIR / OPTIONAL: DIVIDING RAIL S 800

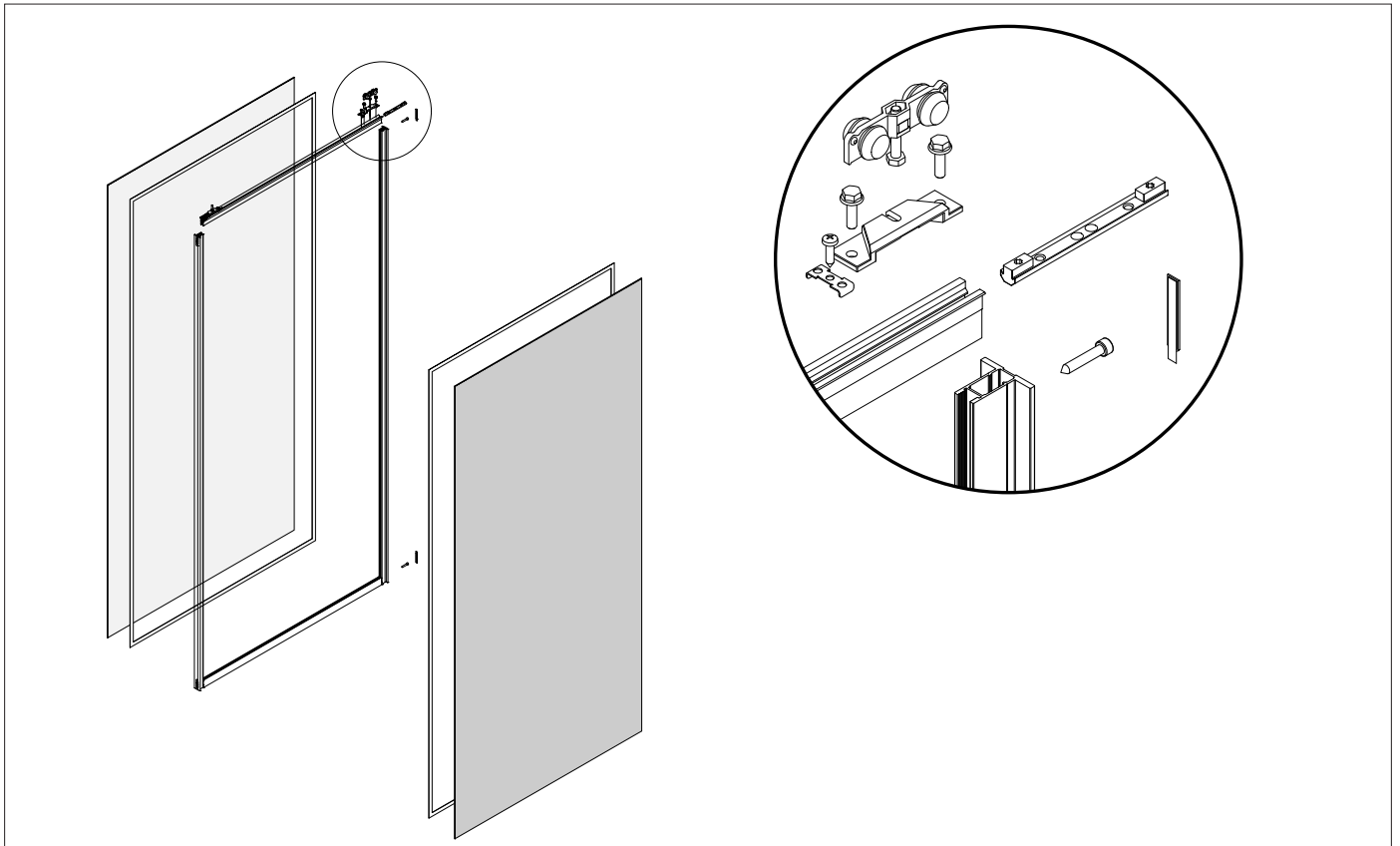

1_ S 8000 system AIR

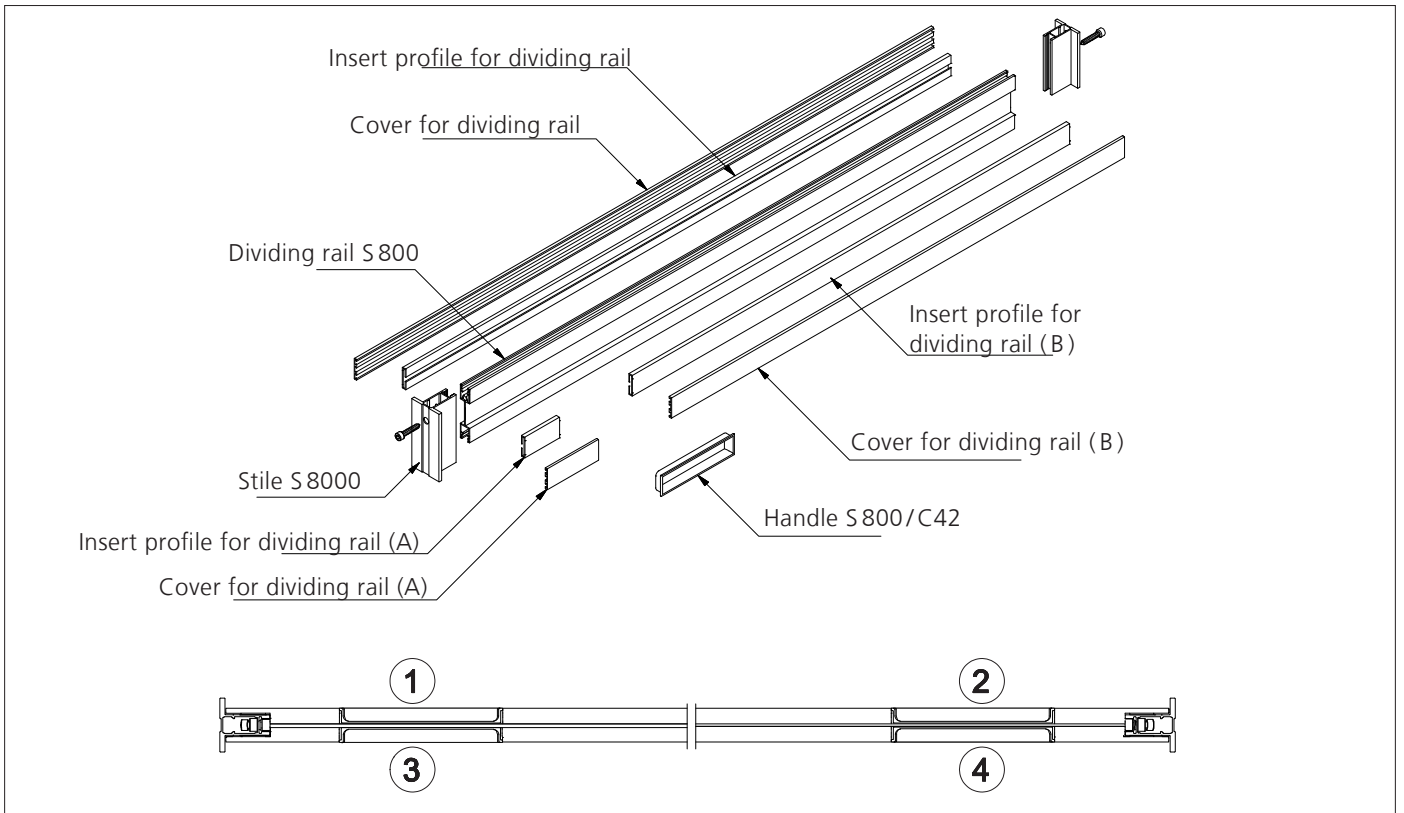

2_ Optional: dividing rail and handle S 800, possible variations

CUTTING DIMENSION

S 8000 SYSTEM AIR

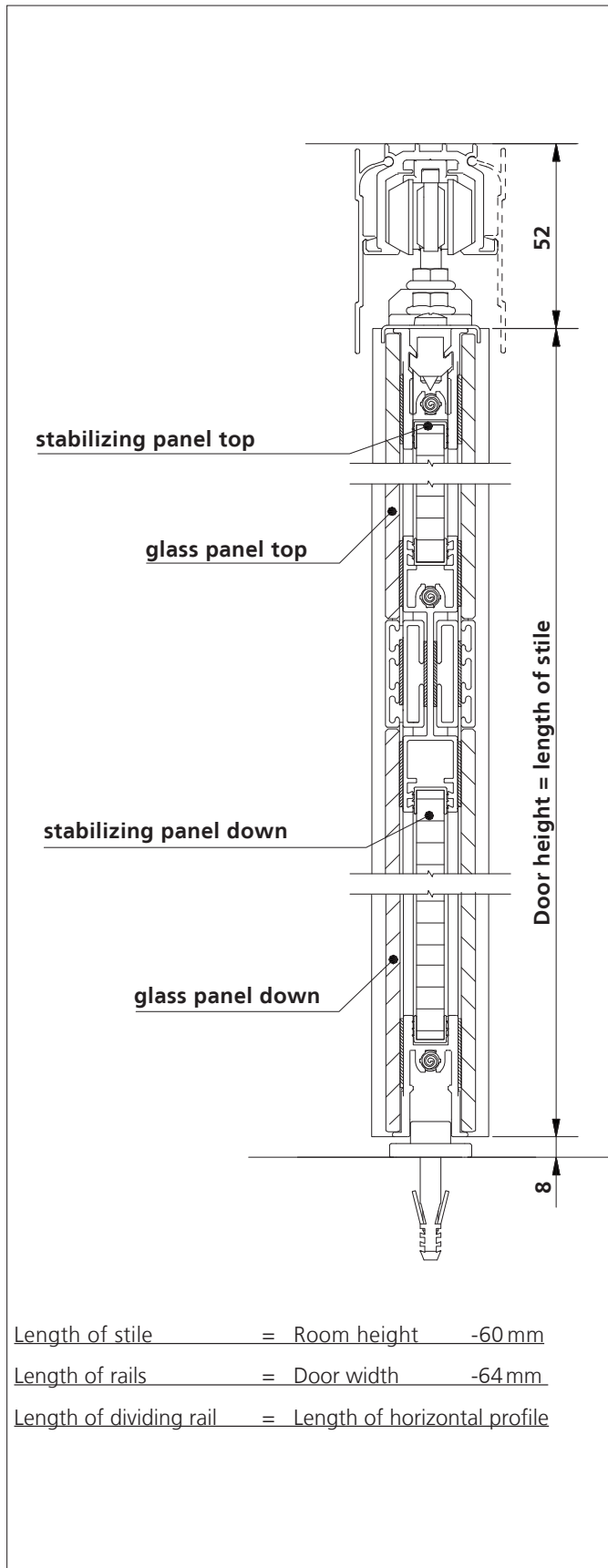

1_ Cross section vertical / cutting dimension

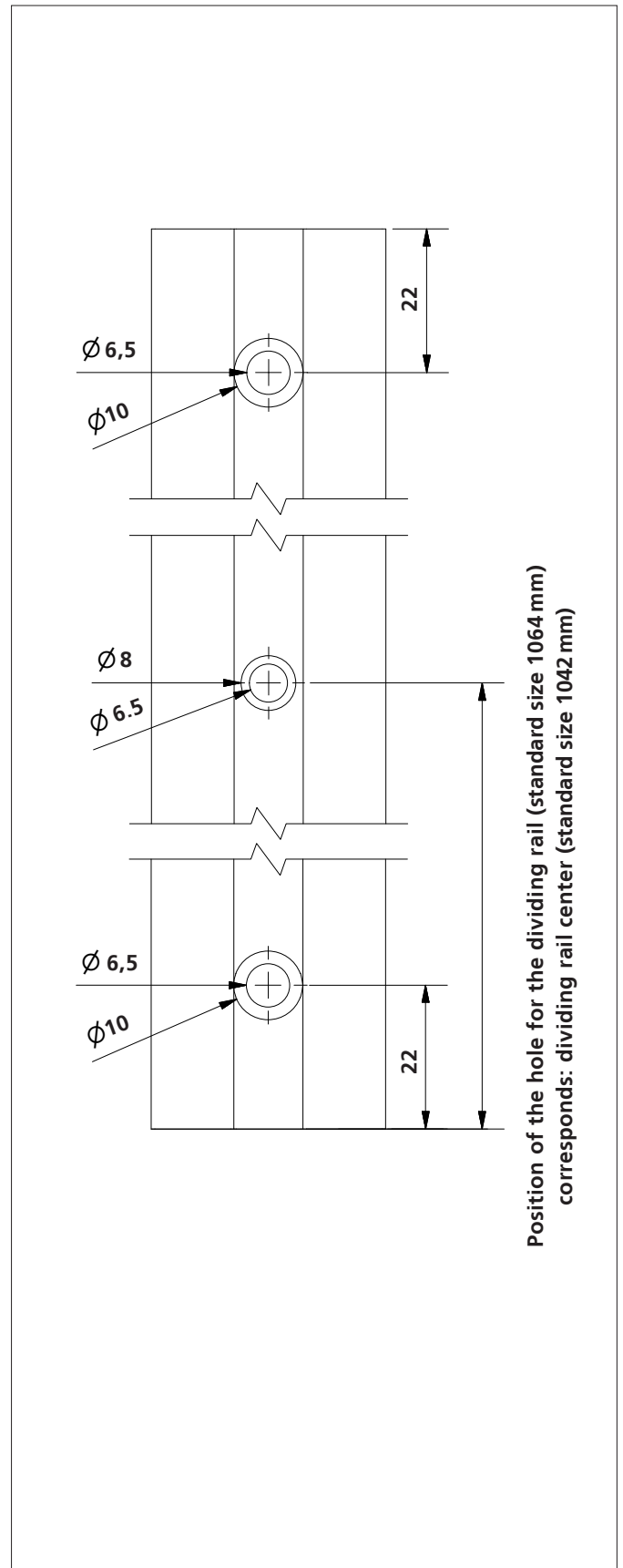

2_ Drill hole in vertical profile

CUTTING DIMENSION

DIVIDING RAIL / HANDLE SYSTEM AIR

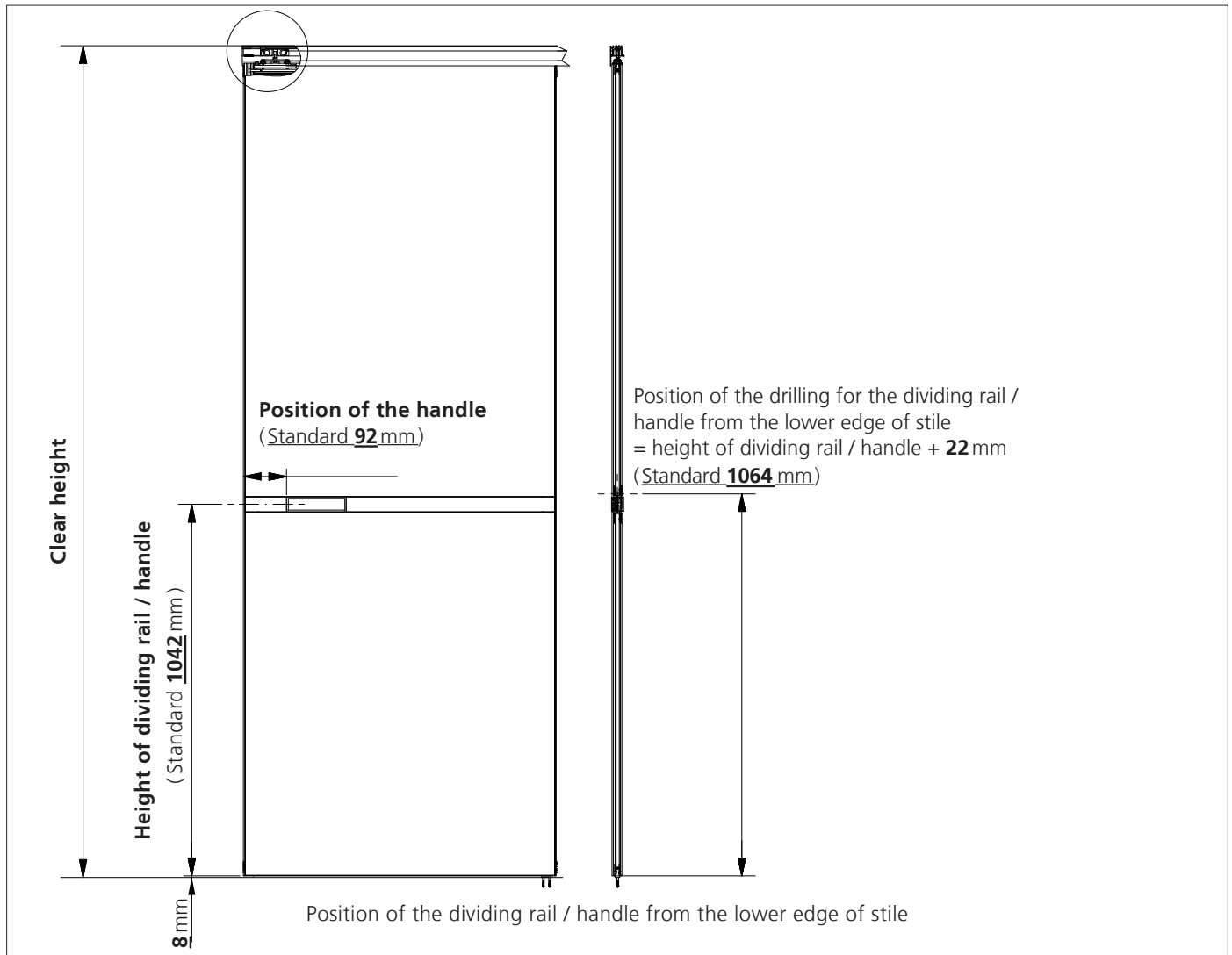

3_ Position of the dividing rail / handle

Cutting dimension stabilizing panel 8 mm without dividing rail

Width stabilizing panel **(A) = Door width -52 mm**

Height stabilizing panel **(B) = Door height -57 mm**

Cutting dimension stabilizing panel 8 mm with dividing rail

Width stabilizing panel **(A) = Door width -52 mm**

Height stabilizing panel **(B) = Door height - height of dividing rail / handle -62 mm**

Height stabilizing panel **(C) = Door height - height of dividing rail / handle -62 mm**

(Standard 980 mm)

4_ Cutting dimension stabilizing panel

CUTTING DIMENSION

DIVIDING RAIL AND HANDLE S800

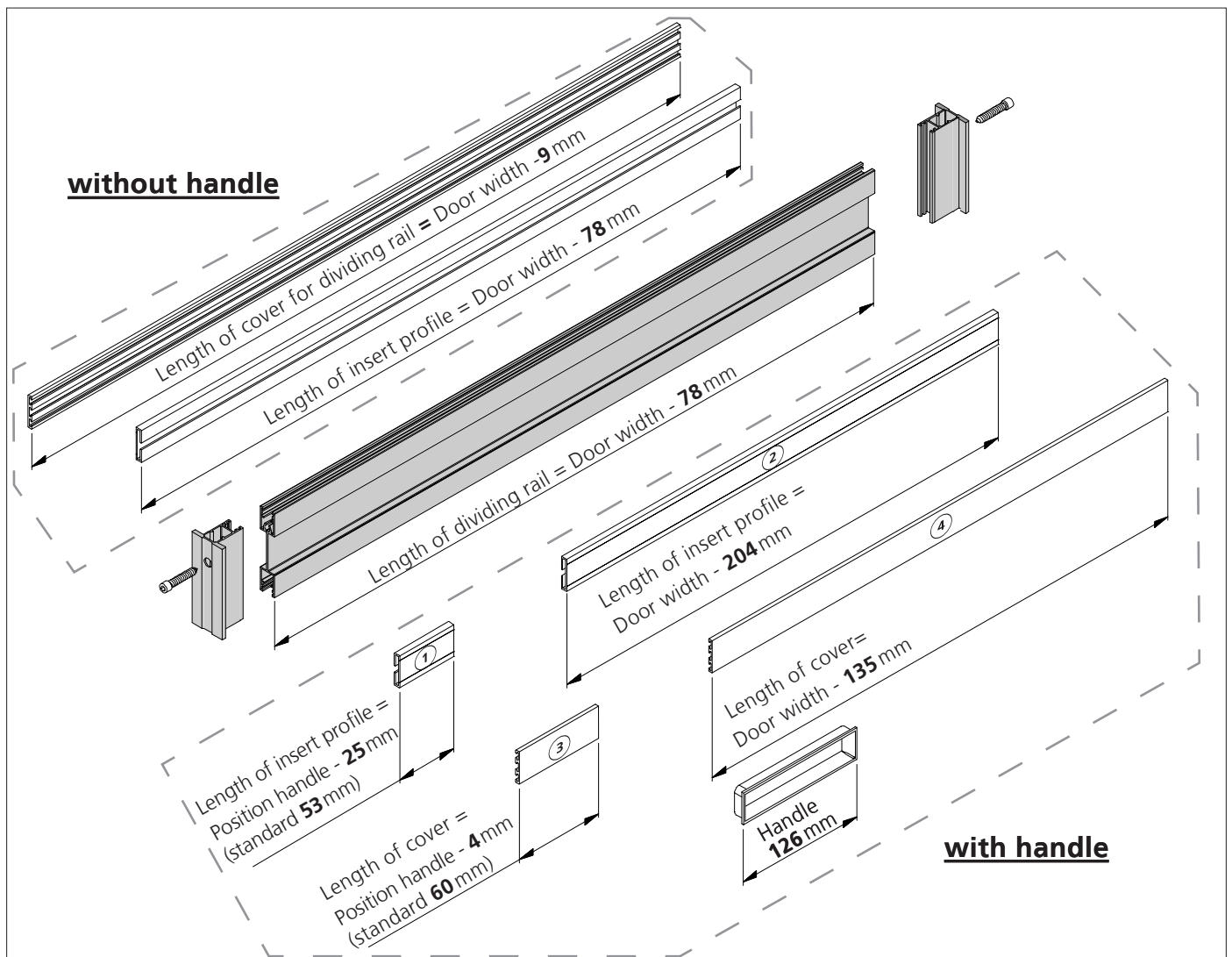

2_ Cutting dimensions for handle and dividing rail

Cutting dimensions for glass panel 4 mm without dividing rail

Width glass panel (A) = Door width - 9 mm

Height glass panel (B) = Door height - 5 mm

Cutting dimensions for glass panel 4 mm with dividing rail

Width glass panel (A) = Door width - 9 mm

Height glass panel (B) = Door height - Height of dividing rail / handle - 18 mm

Height glass panel (C) = Height of dividing rail / handle - 18 mm

(Standard 1024 mm)

3_ Cutting dimensions for glass panel

ASSEMBLY INSTRUCTIONS

STABILIZING PANEL

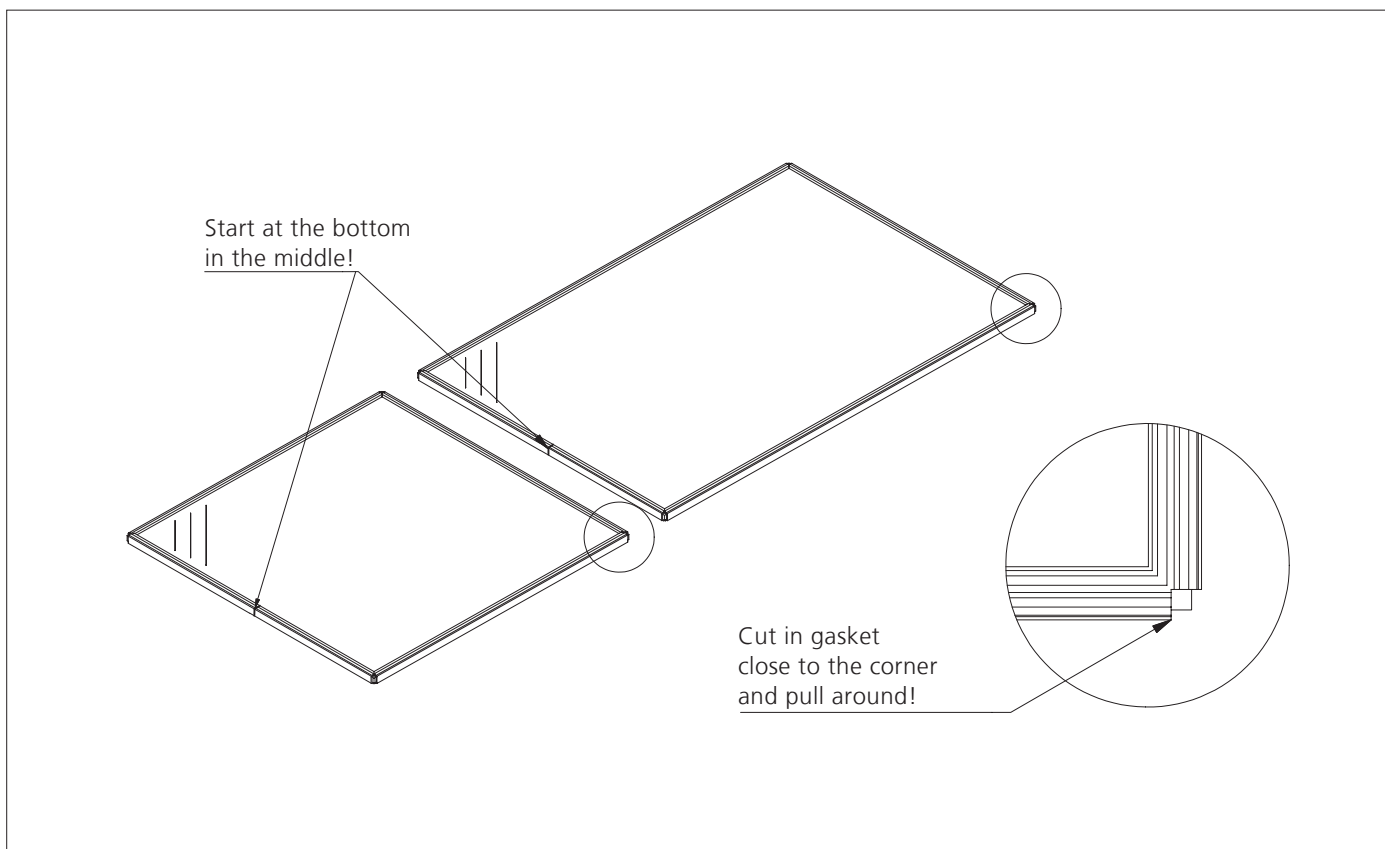

1_ Place panel on a table, affix gasket

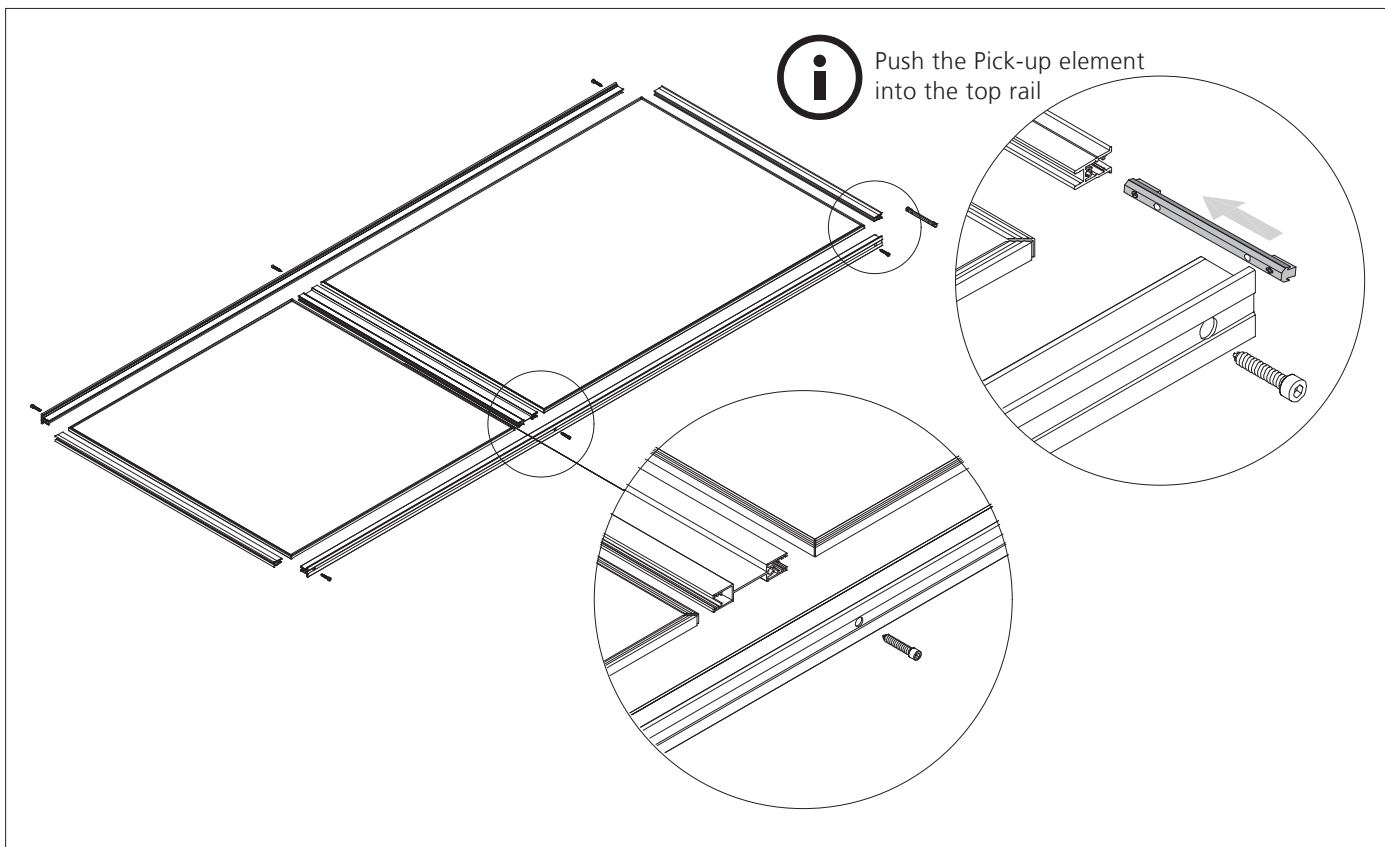

2_ Attach the vertical profile and the cross profiles, pound it well with the rubber hammer

ASSEMBLY INSTRUCTIONS

PREPARATION OF ADHESIVE SURFACES

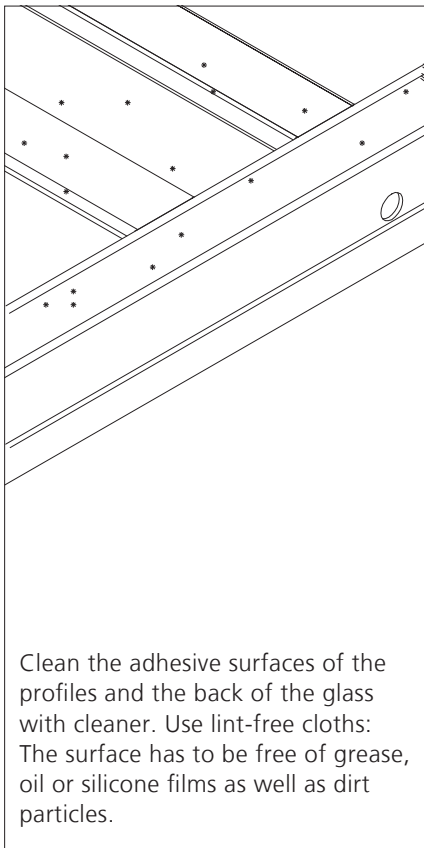

3_ Cleaner

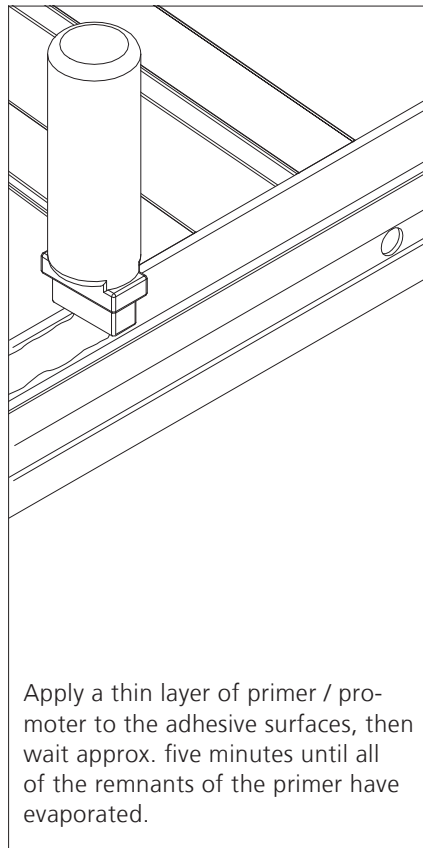

4_ Primer / Promoter

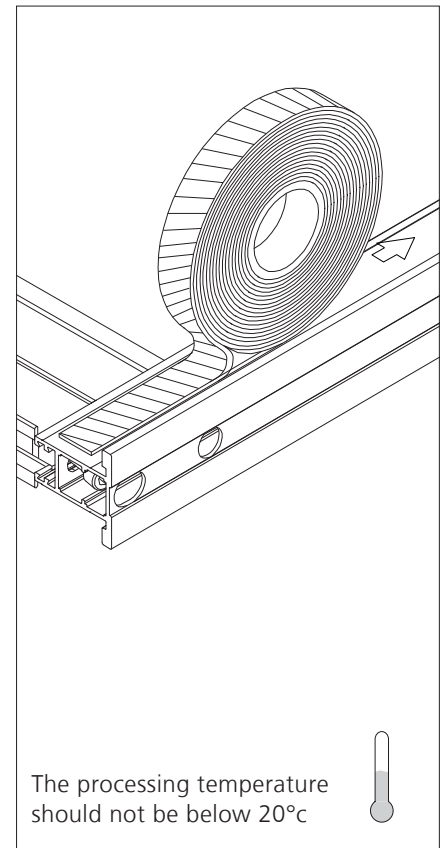

5_ Adhesive tape

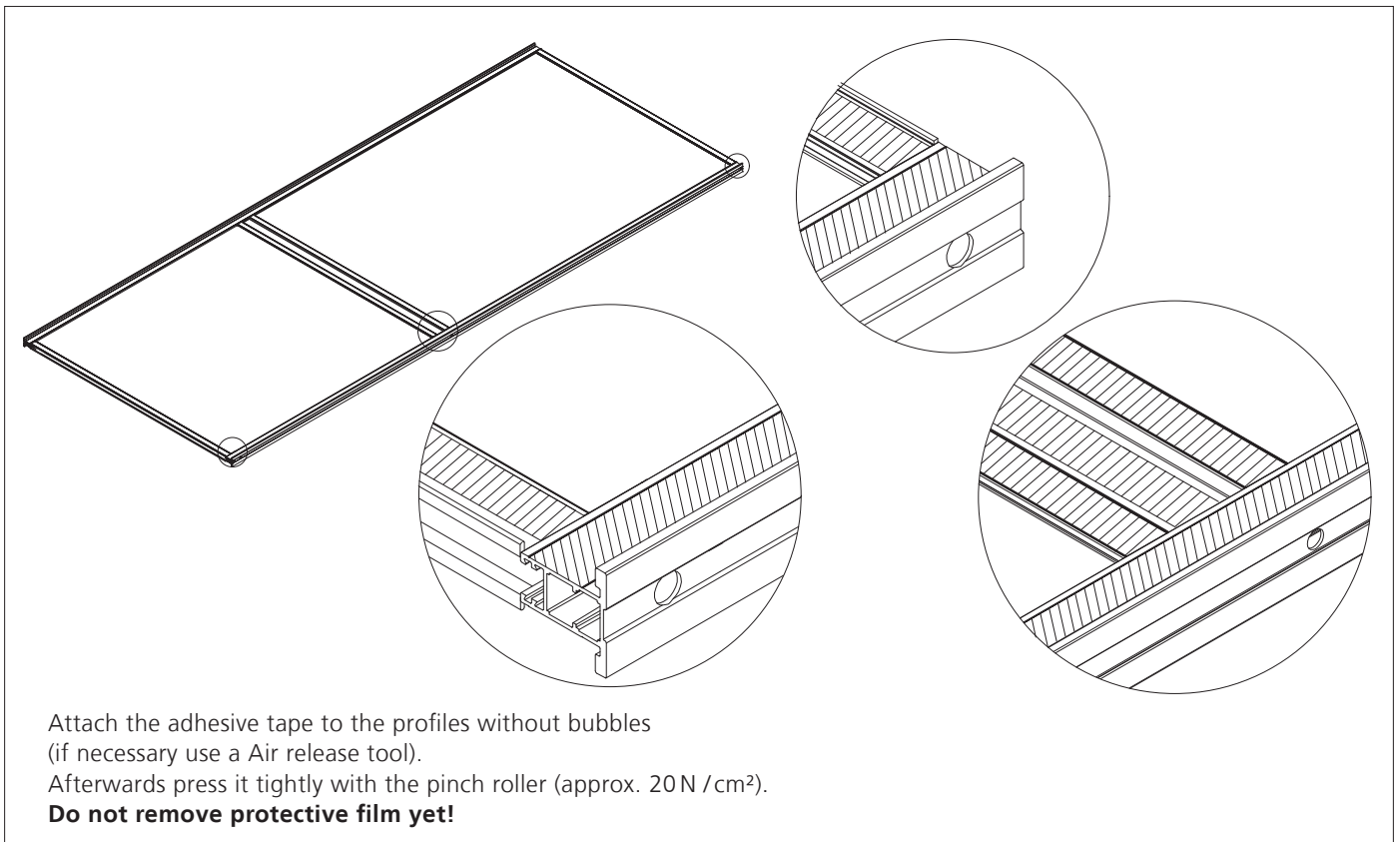

6_ Press on tape

ASSEMBLY INSTRUCTIONS

GLUING THE GLASS PANEL

Place the glass panel, insert profile for dividing rail, cover for dividing rail and handle on the frame as a test and if necessary align the frame again.

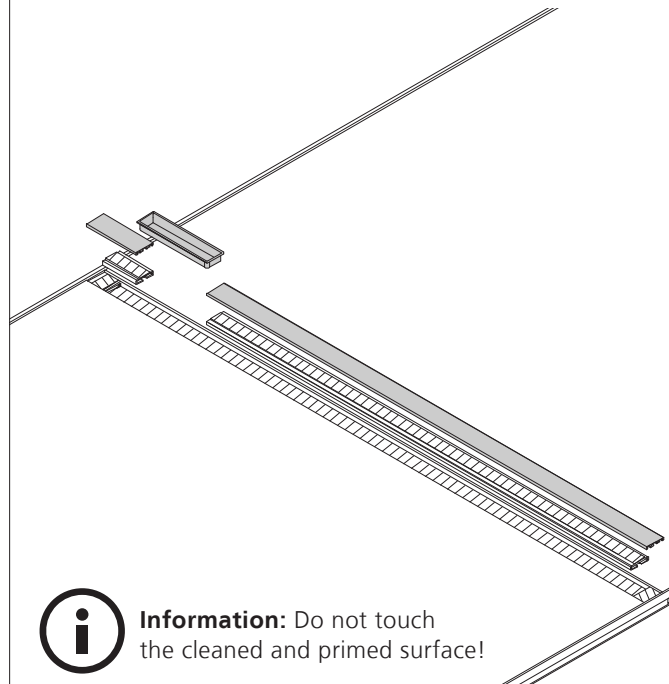

7_ Preparation of gluing

Clean and prime the adhesive surface, before gluing the glass panel. Remove the protective film from the vertical profile, horizontal bottom and top profile and the dividing rail. **Do not remove** the protective film for **dividing rail, insert profile, cover and handle!**

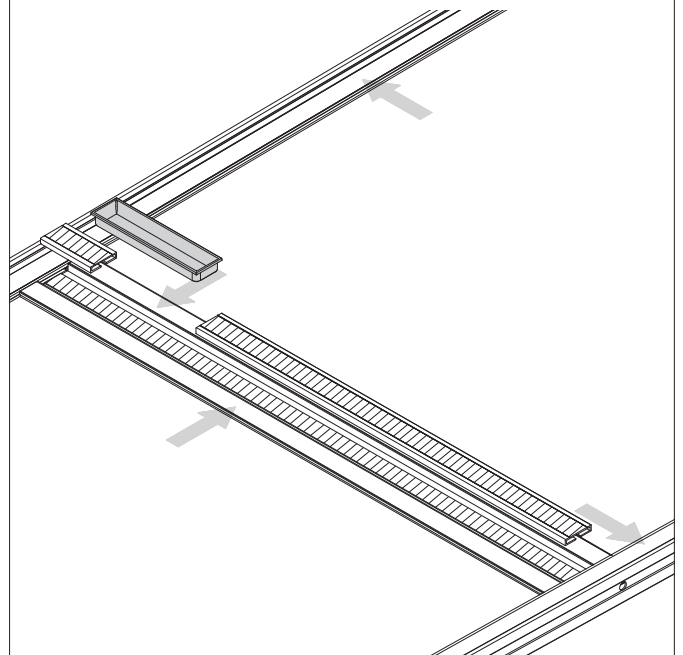

8_ Preparation of gluing

1. Please position the gluing device. Place the glass panel on top and align it. Please make sure, that you use glass suction cups to attach the glass panel.
2. Drive in the bolt of the gluing device and position the panel exactly. Then put the gluing device off from the bottom to the top.

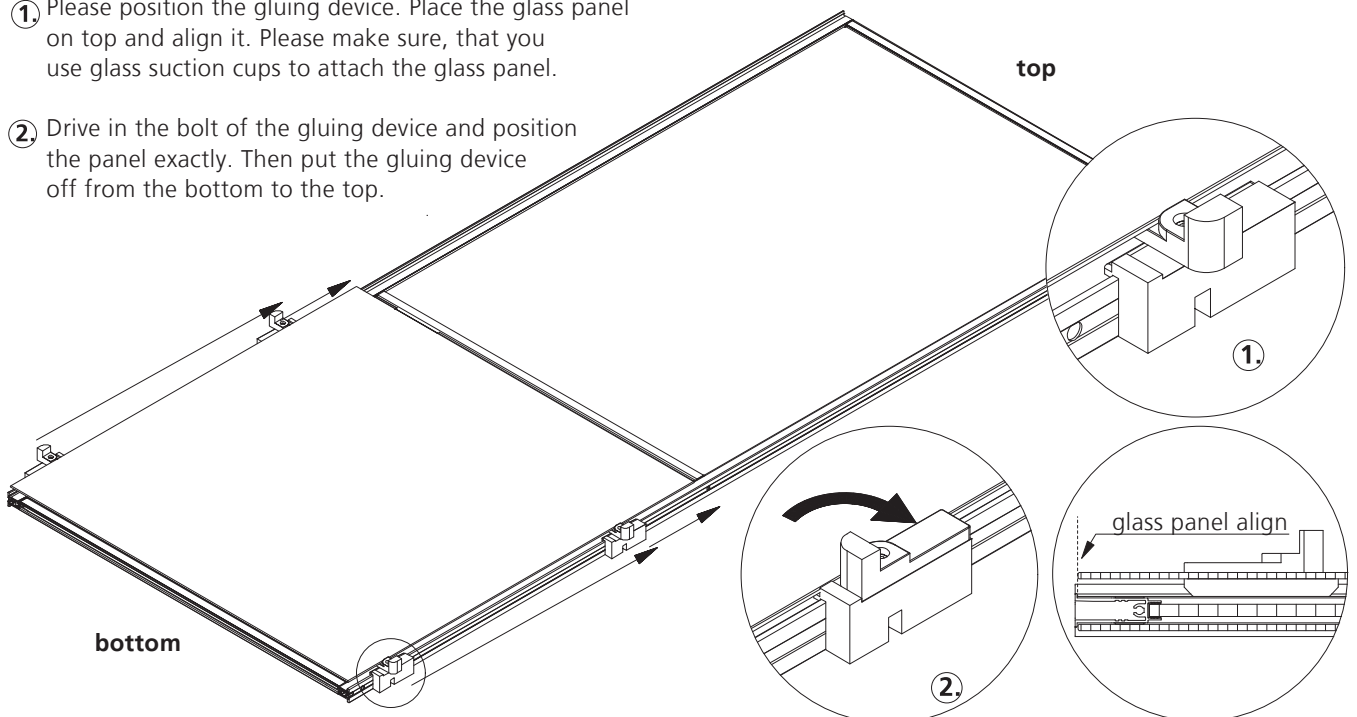

9_ Perform this workstep by two persons / Precision work is very important!

ASSEMBLY INSTRUCTIONS

INSERT DIVIDING RAIL AND HANDLE

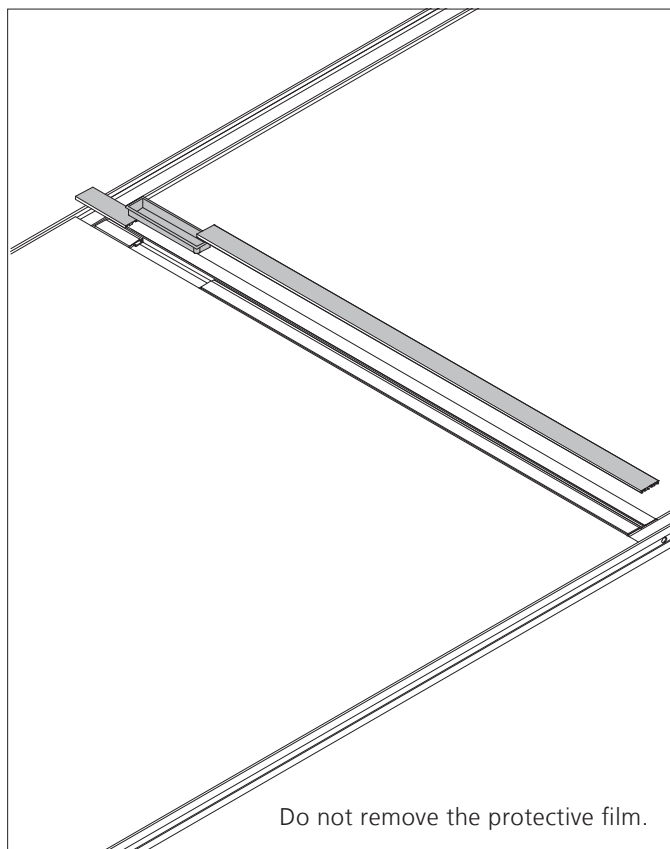

10_ Insert the insert profile, cover and the handle

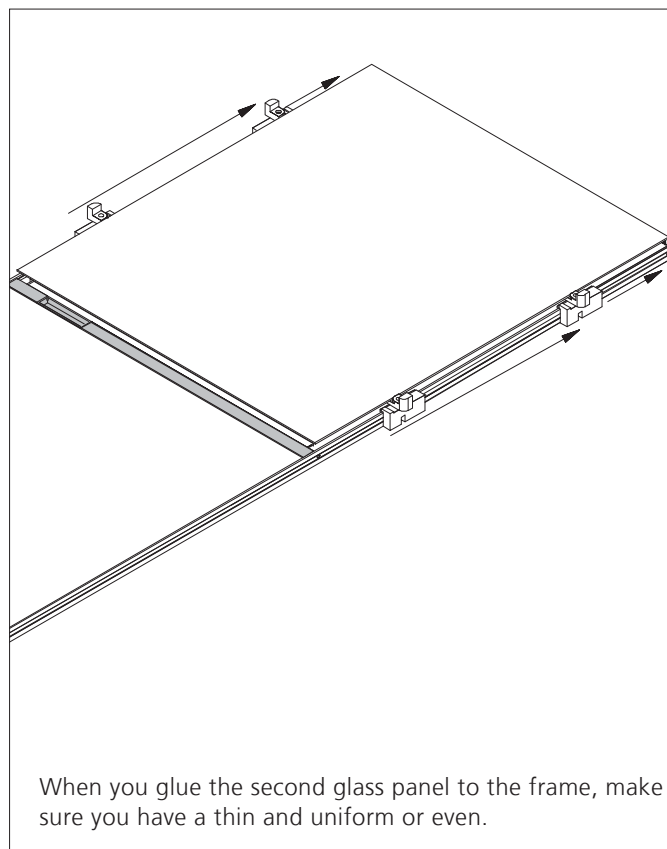

11_ Glue the second glass panel

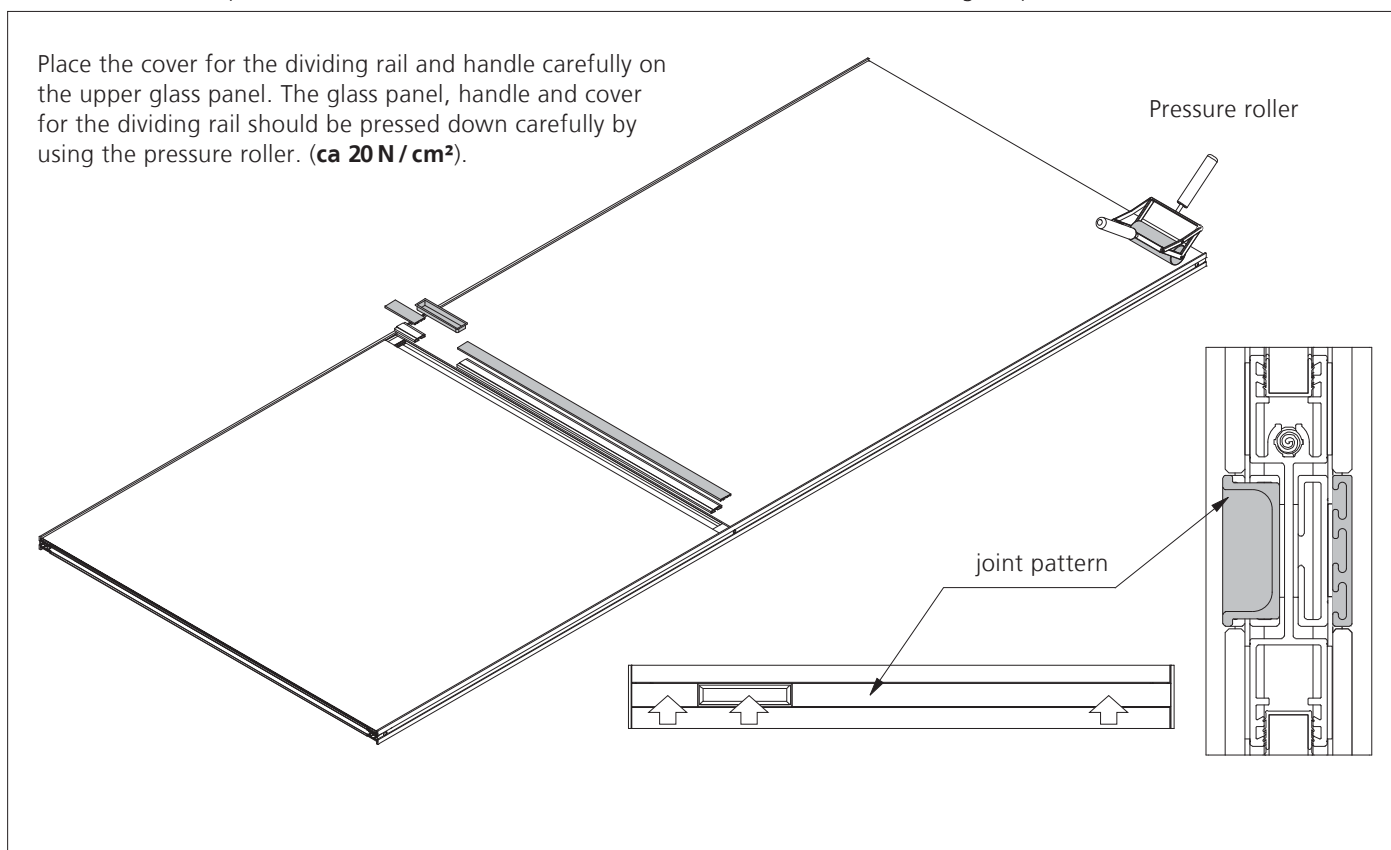

12_ Use the insert profile for dividing rail, cover for dividing rail and the handle

DETAIL DRAWING

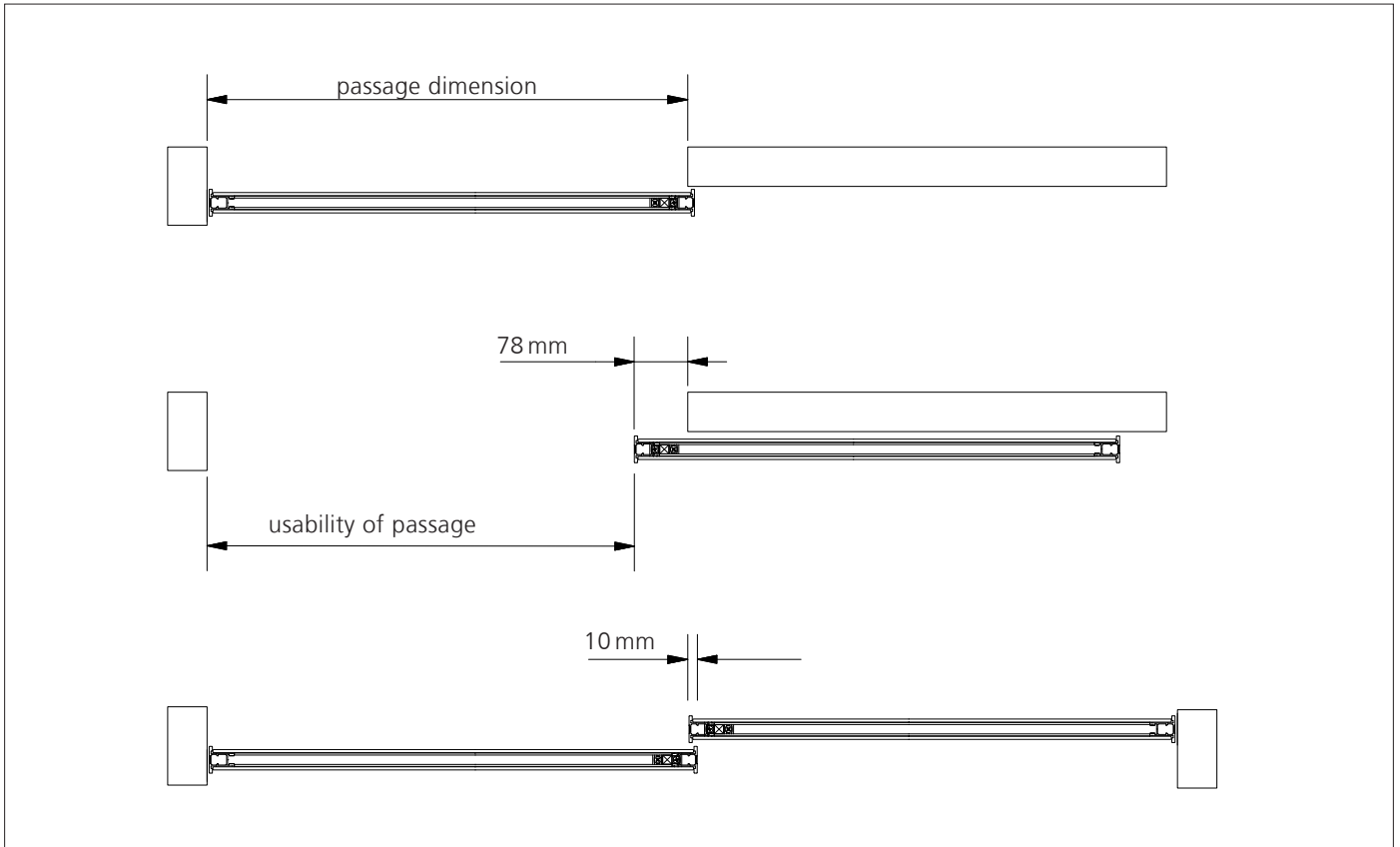

1_ Overlapping S8000

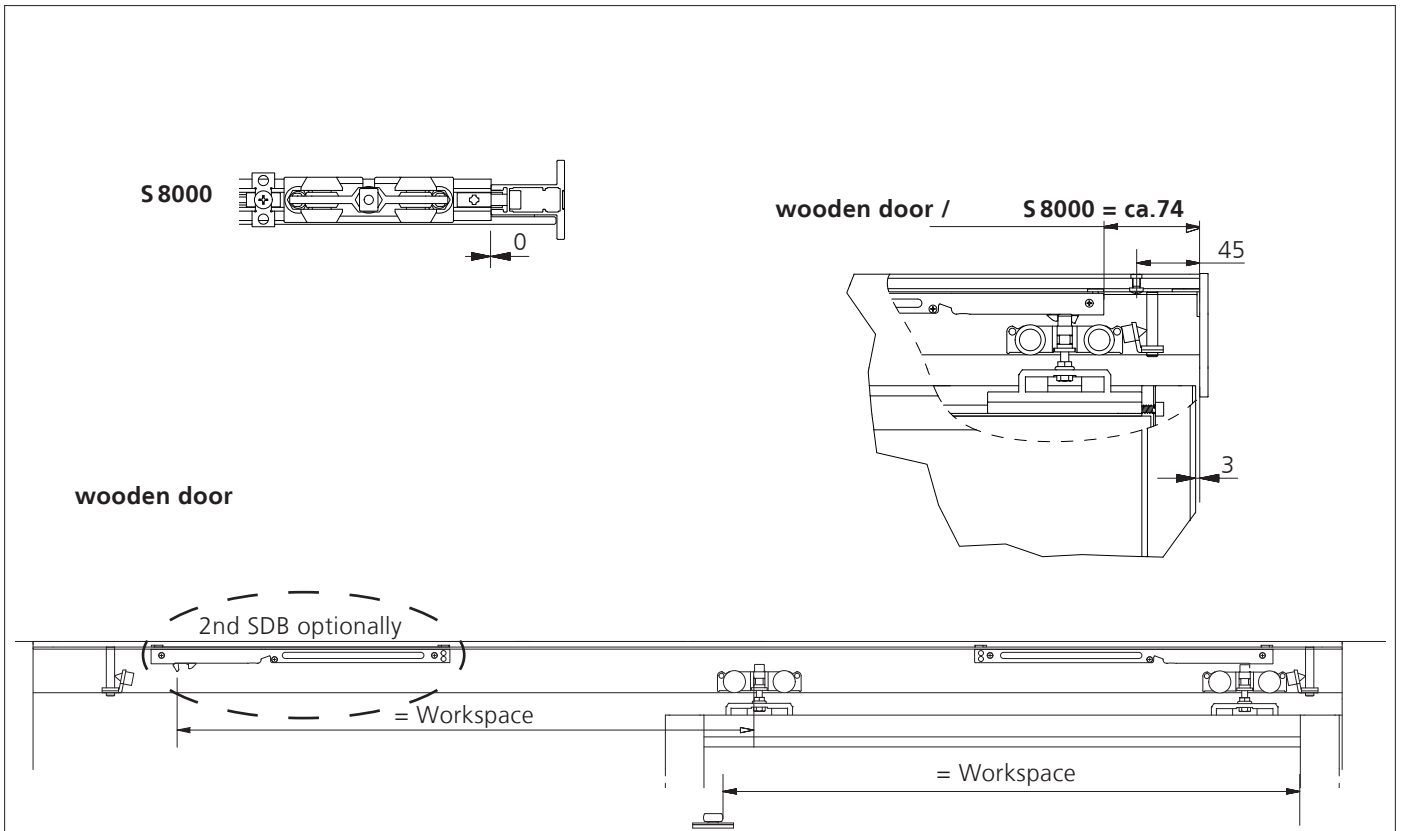

7_ Positioning of the sliding door brake

ACCESSORIES

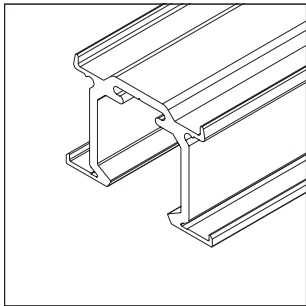

1_ 14.55.0xx

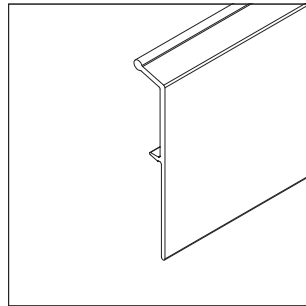

2_ 14.53.0xx

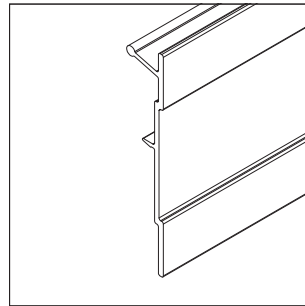

3_ 14.50.0xx

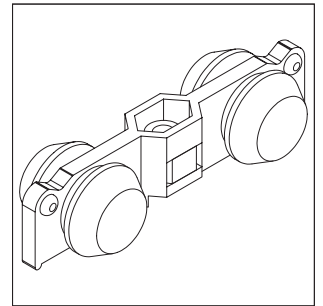

4_ 10.06.200

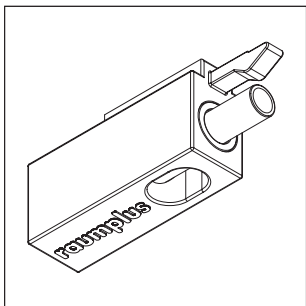

5_ 10.05.017

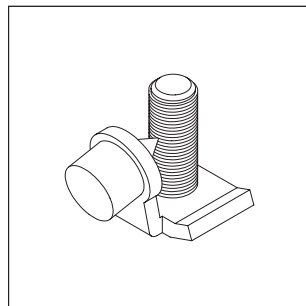

6_ 10.05.060

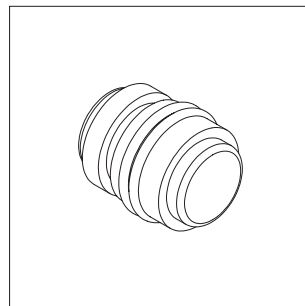

7_ 10.05.030

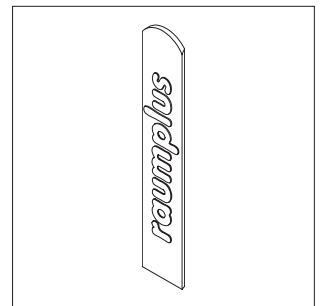

8_ 10.07.05x

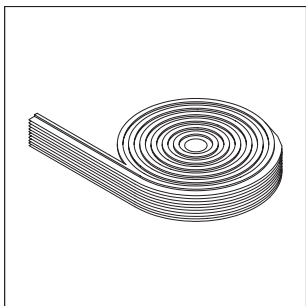

9_ 10.07.02x

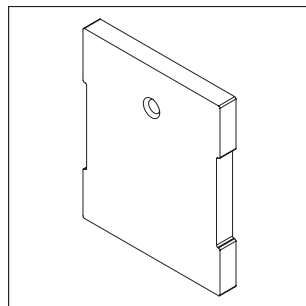

10_ 10.05.291

1_ Top track insert AIR

2_ Middle insert profile AIR

3_ Cover for top track insert AIR

4_ Top roller AIR

5_ Stopper for top roller with door brake AIR

6_ Stopper for top track AIR

7_ Brake for top roller AIR

8_ Plug for punching holes

9_ Dust excluding brush, grey

optionally:

10_ End cap for insert profile

w / o illustration:

11_ End cap for wall connection profile

Art.: 10.05.2xx

12_ Connector for end cap

Art.: 10.05.290

13_ Screw for wall connection profile

Art.: 10.07.081

14_ Nut for wall connection profile

Art.: 10.07.082

15_ Wall connection profile Air S42

Art.: 14.54.020

16_ Bracket for dust excluding

Art.: 10.01.039

INSTALLATION INSTRUCTION

TOP TRACK

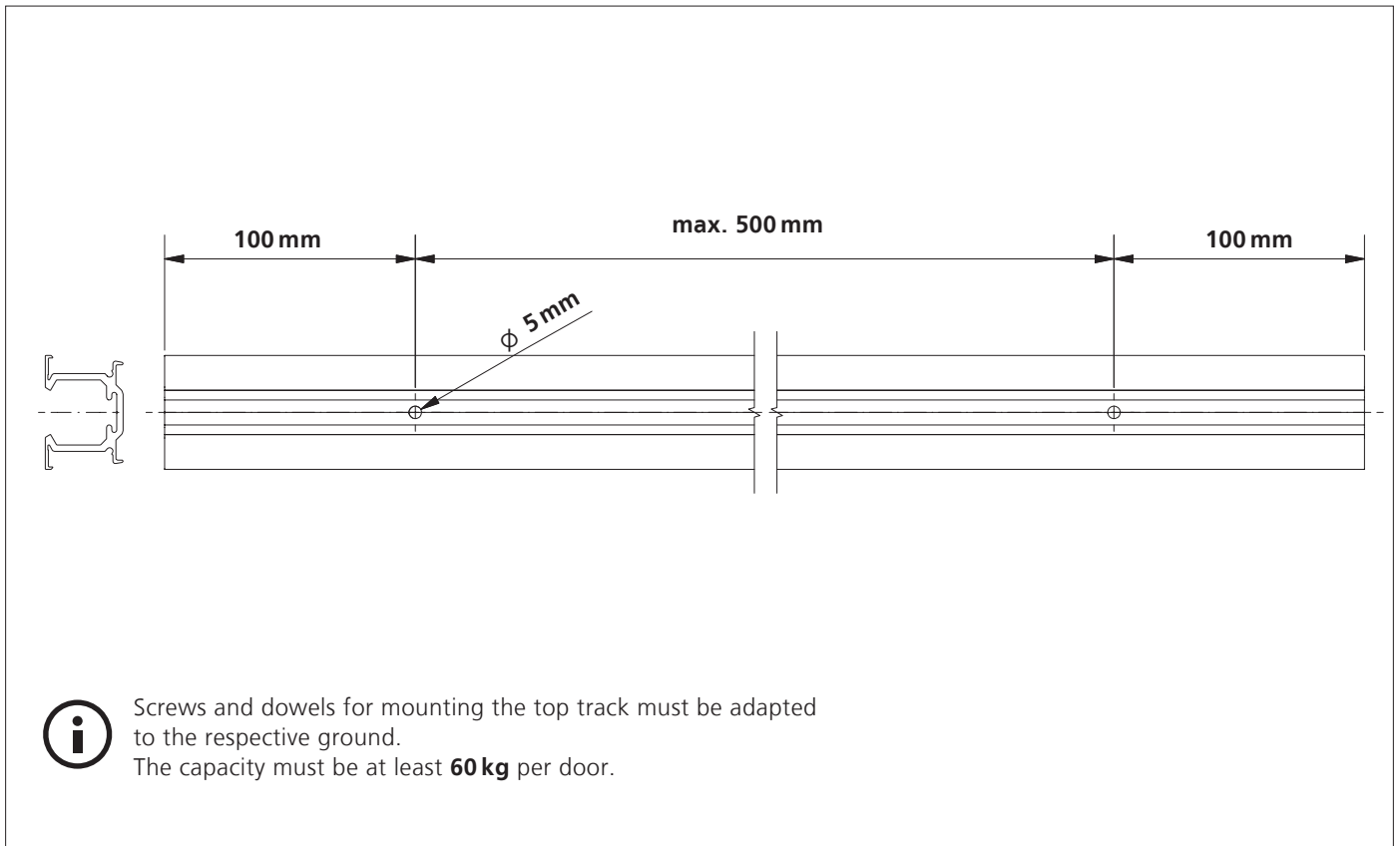

1_ Cut cover for top track, middle insert profile and top track to size, drill holes in top track

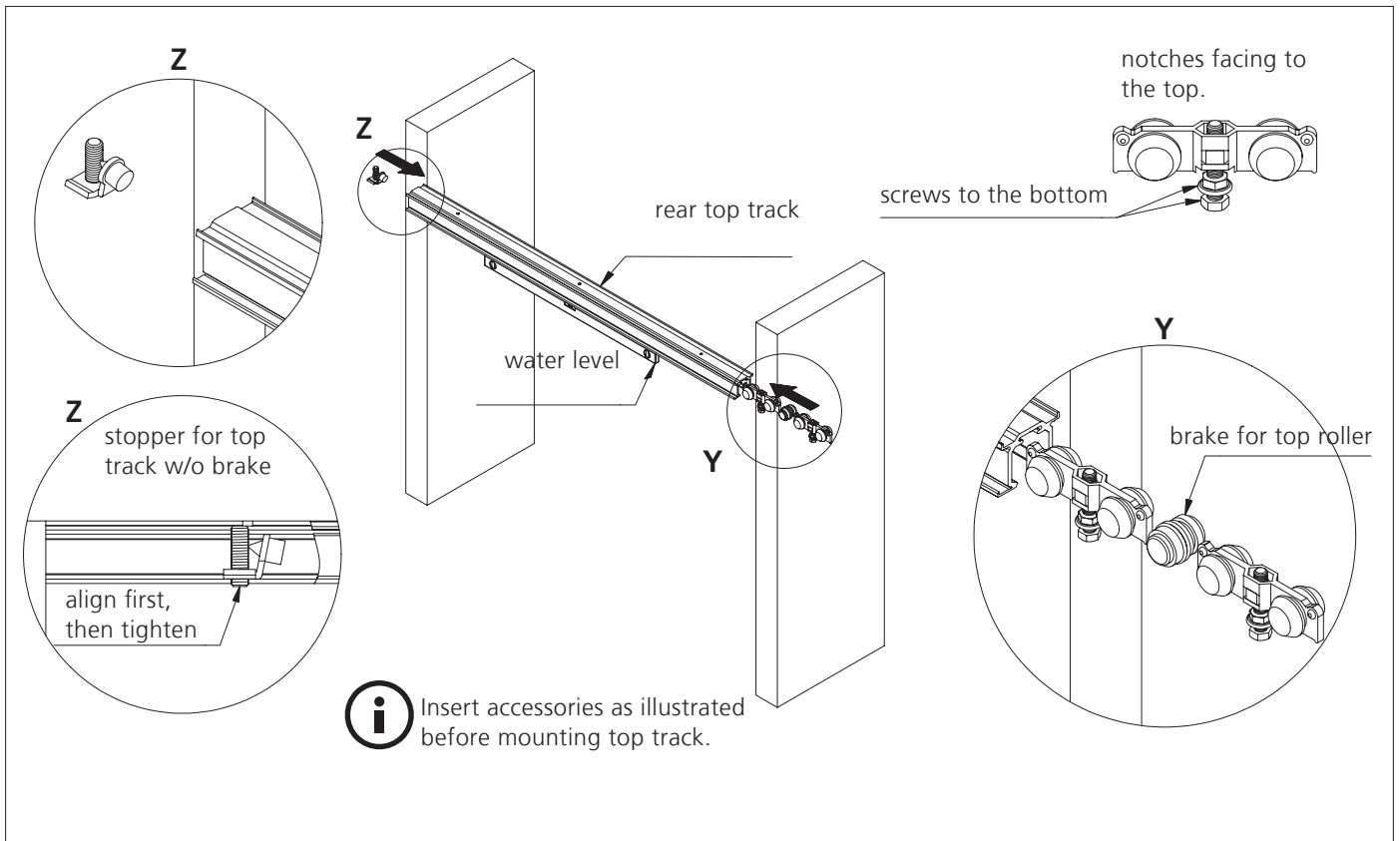

2_ Drill holes in ceiling / top of corpus and mount the rear top track horizontally (fig. w/o ceiling / corpus)

INSTALLATION INSTRUCTION

ADJUST SLIDING DOOR

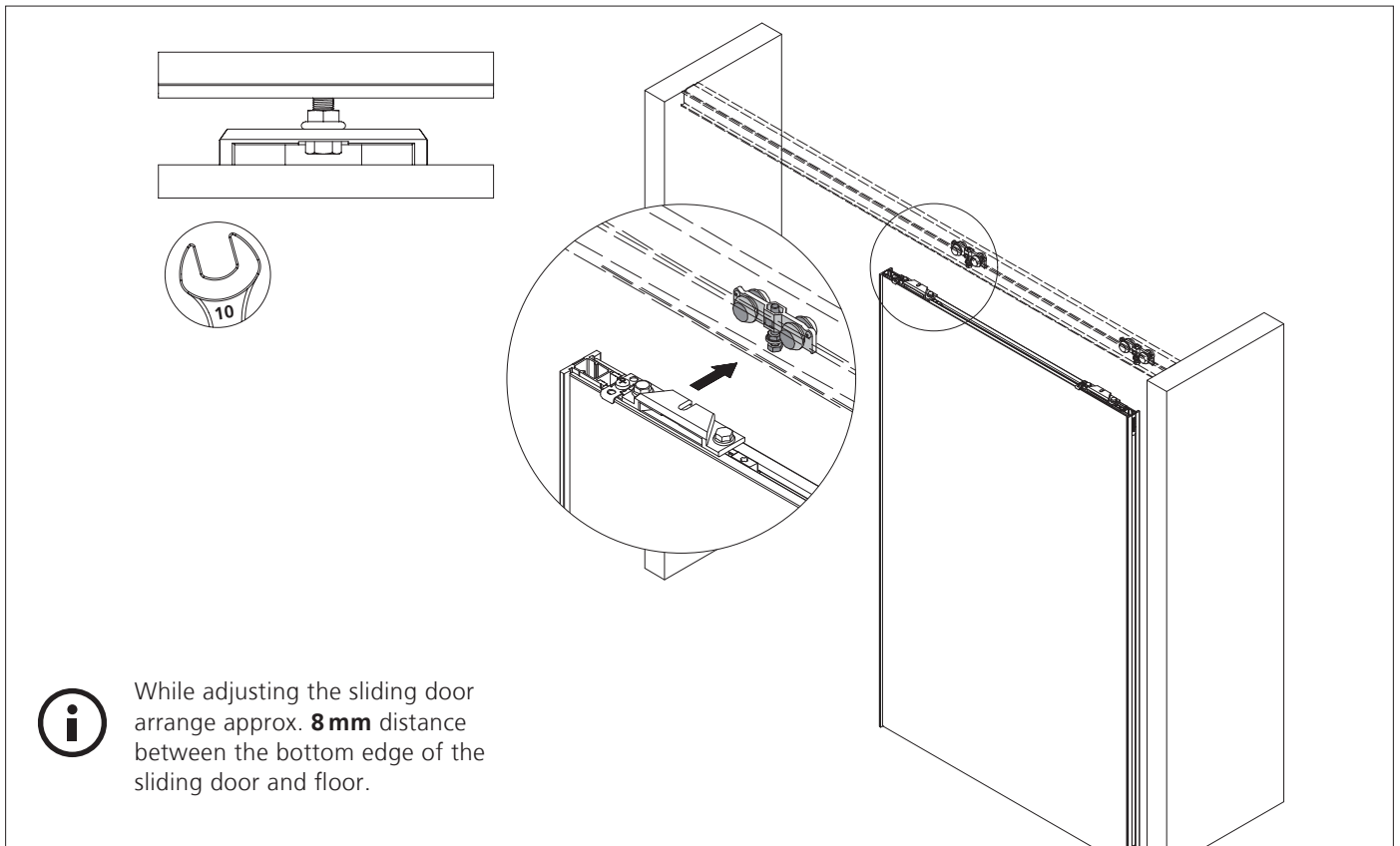

1_ Hinge the rear sliding door and adjust perpendicular with the set screws - do not tighten yet

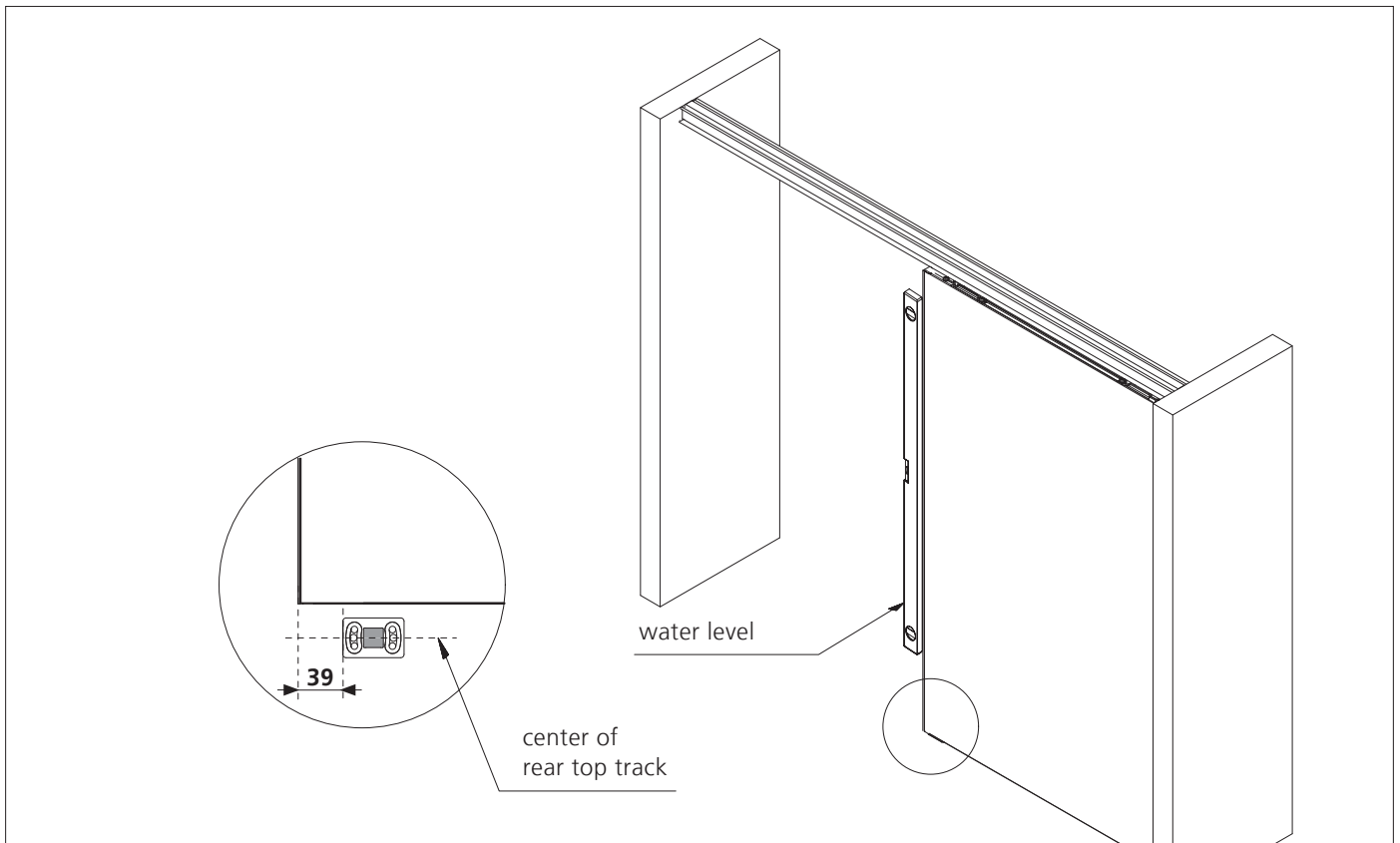

2_ Mark position of ground plate (masking tape/pencil), unhinge rear sliding door and mount ground plate

INSTALLATION INSTRUCTION

BOTTOM GUIDING

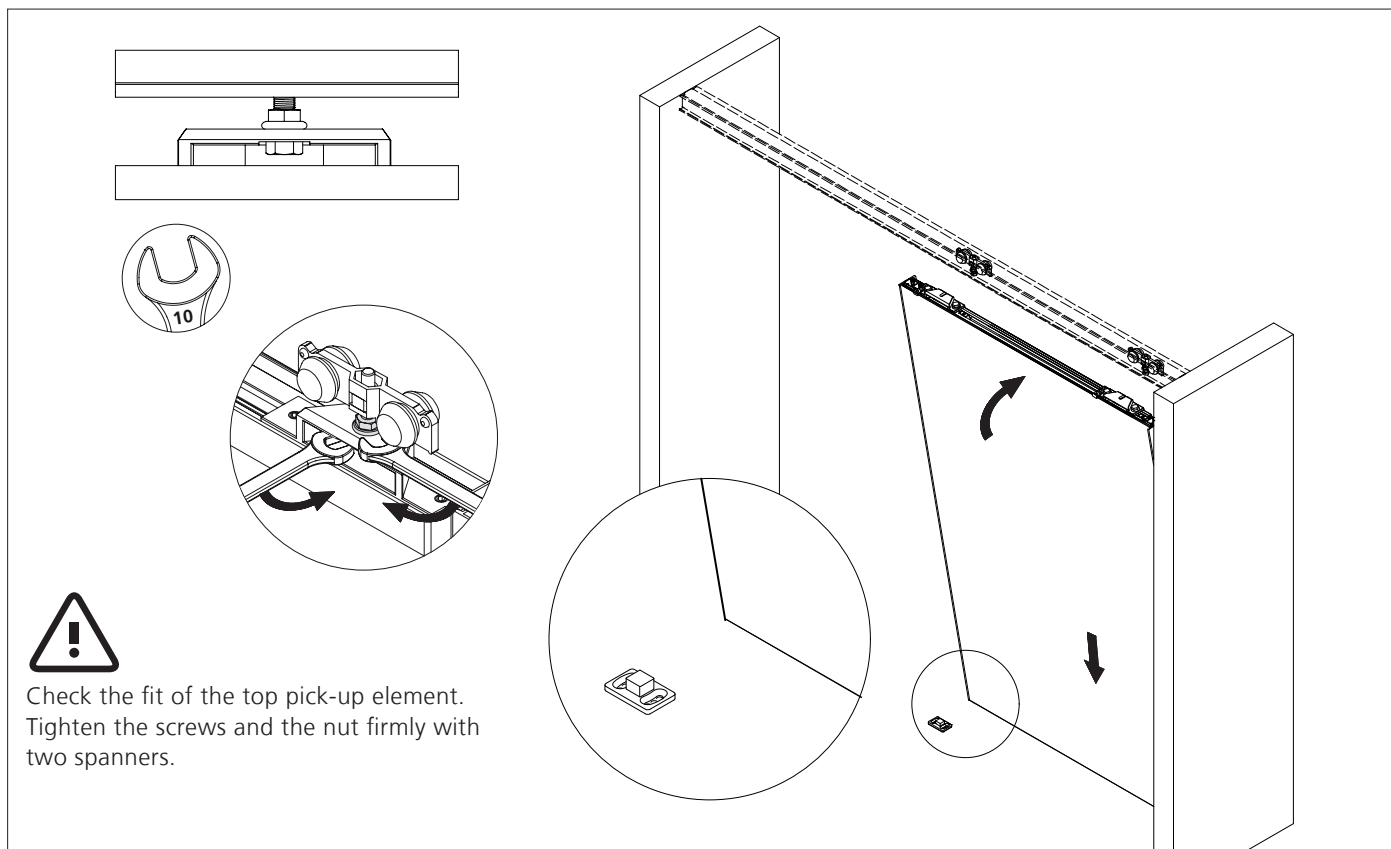

1_ Install rear sliding door, then tighten the counter nuts at the top pick-up elements

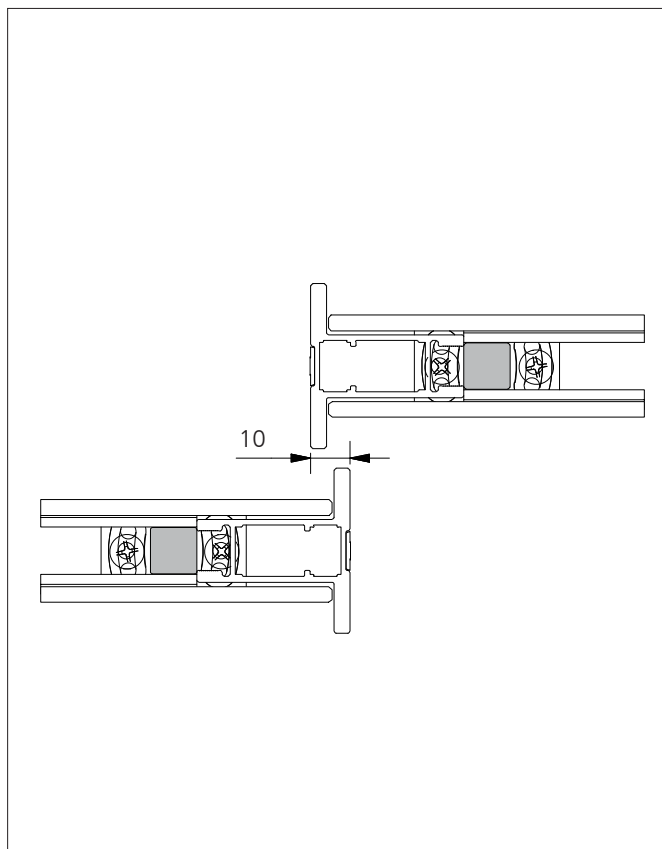

2_ overlap S 800 AIR

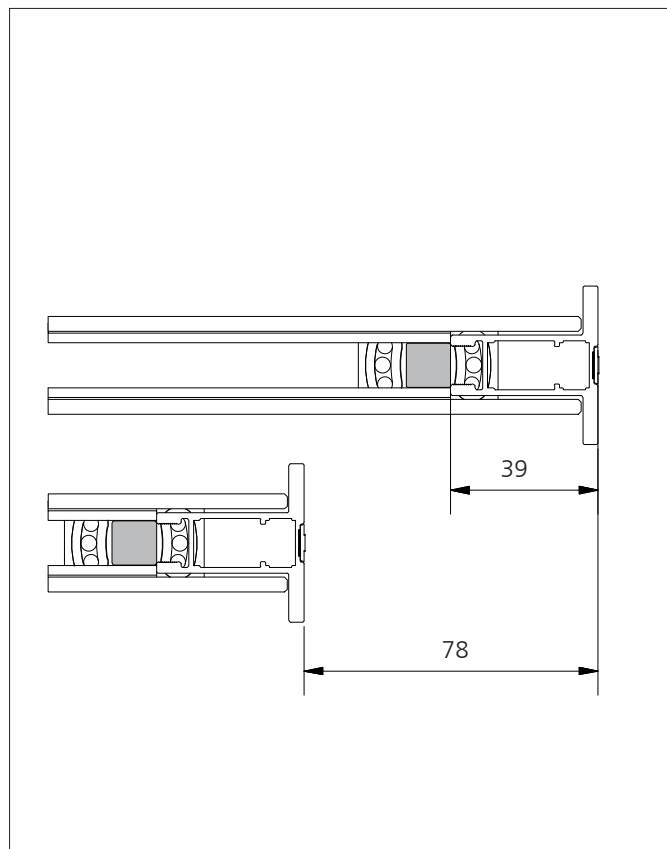

3_ opening restriction S 800 AIR

INSTALLATION INSTRUCTION

SECOND TOP TRACK

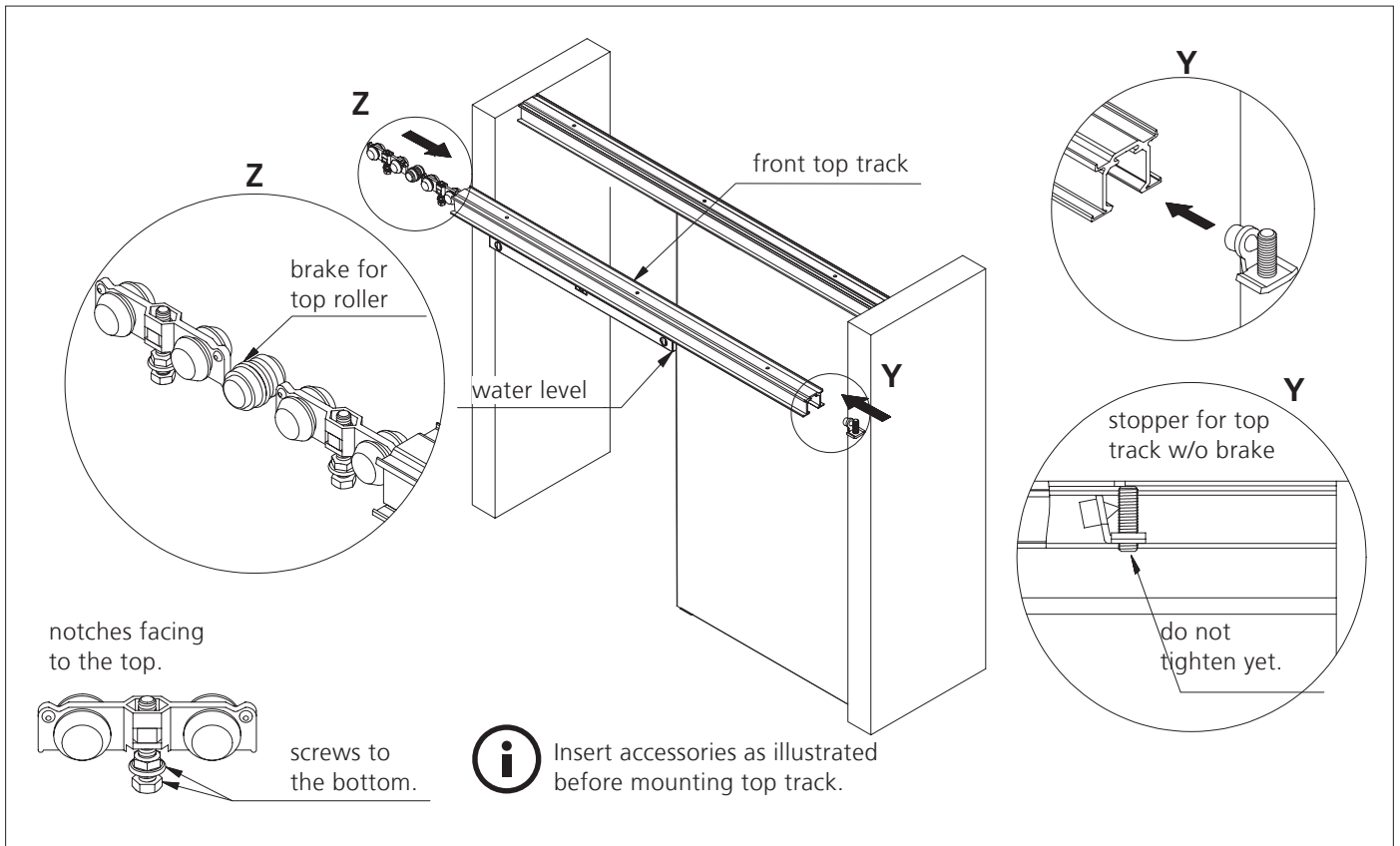

1_ Drill holes in ceiling/top of corpus and mount front top track horizontally (fig. w/o ceiling/corpus)

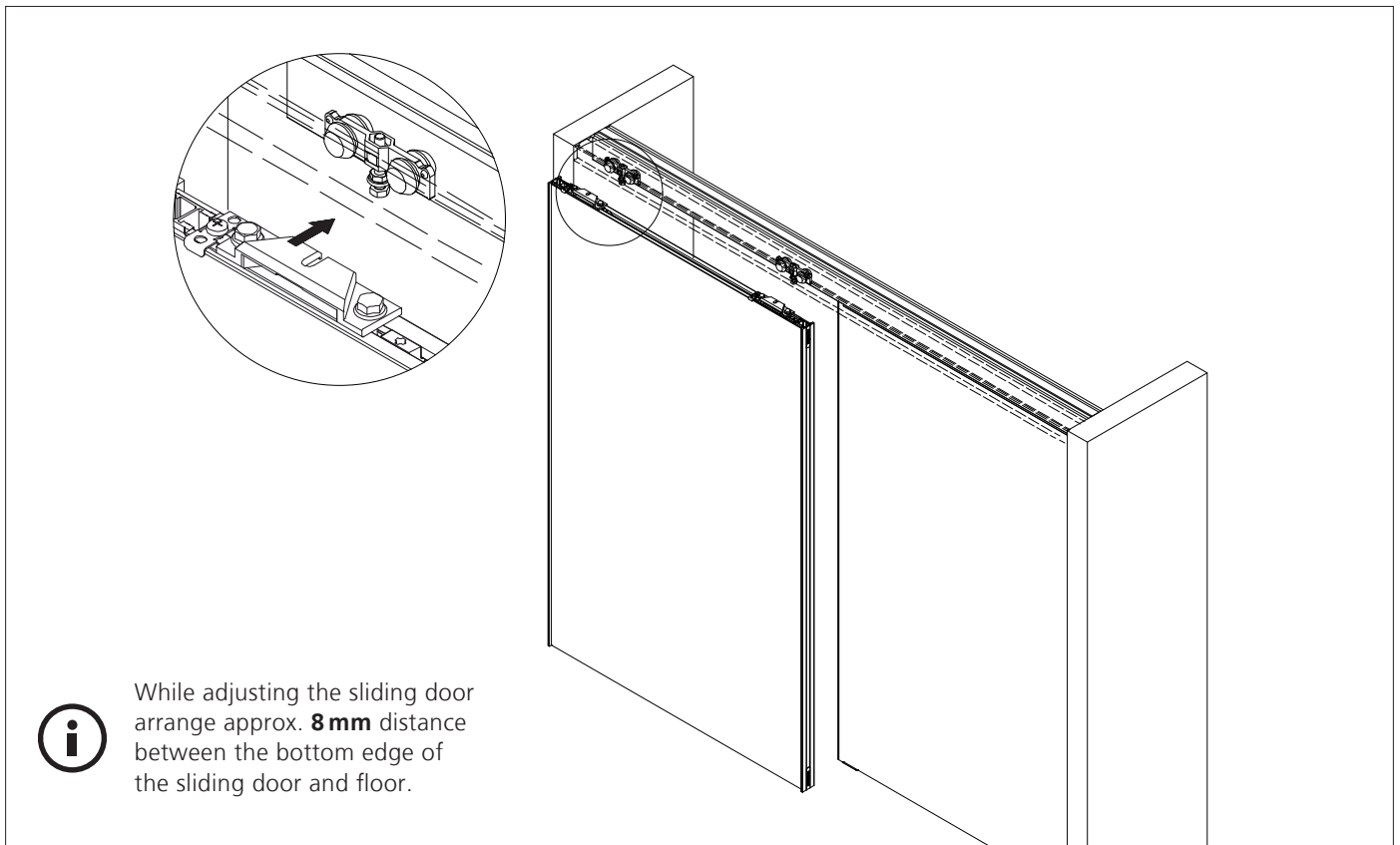

2_ Hinge the rear sliding door and adjust perpendicular with the set screws - do not tighten yet

INSTALLATION INSTRUCTION

BOTTOM GUIDING

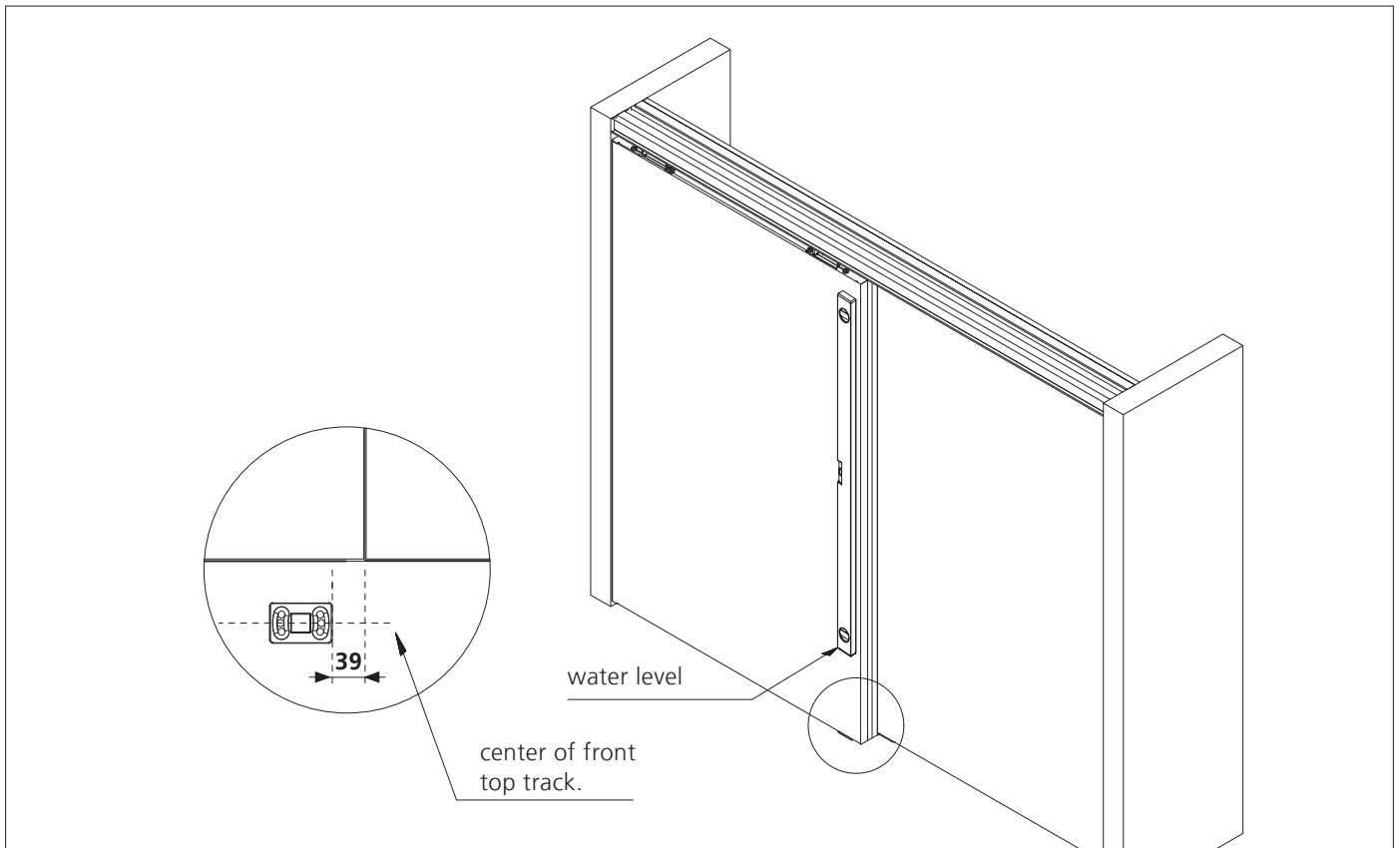

1_ Mark position of ground plate (masking tape / pencil), unhinge rear sliding door and mount ground plate

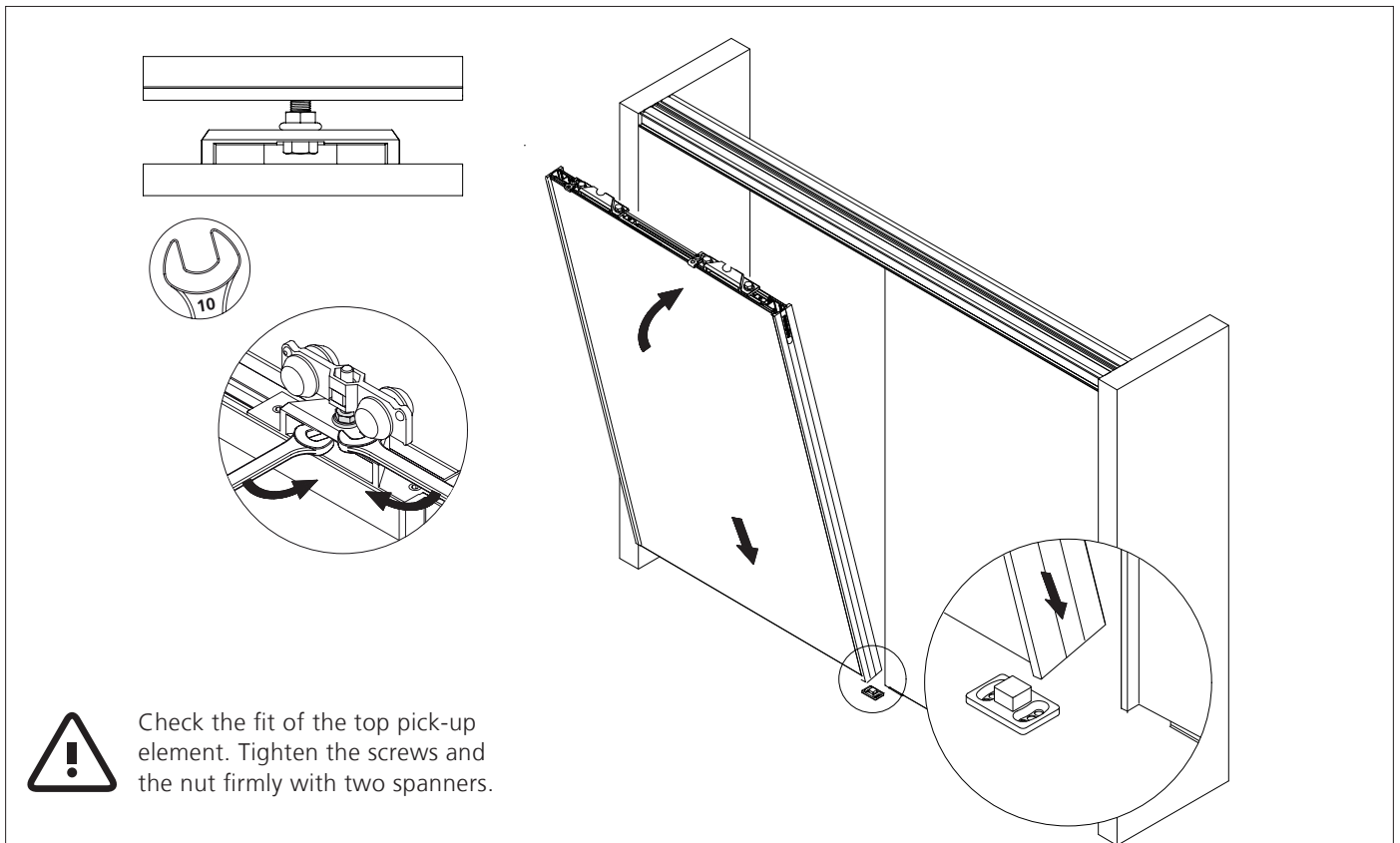

2_ Install front sliding door, then tighten the counternuts at the top pick-up elements

INSTALLATION INSTRUCTION

POSITION STOPPER

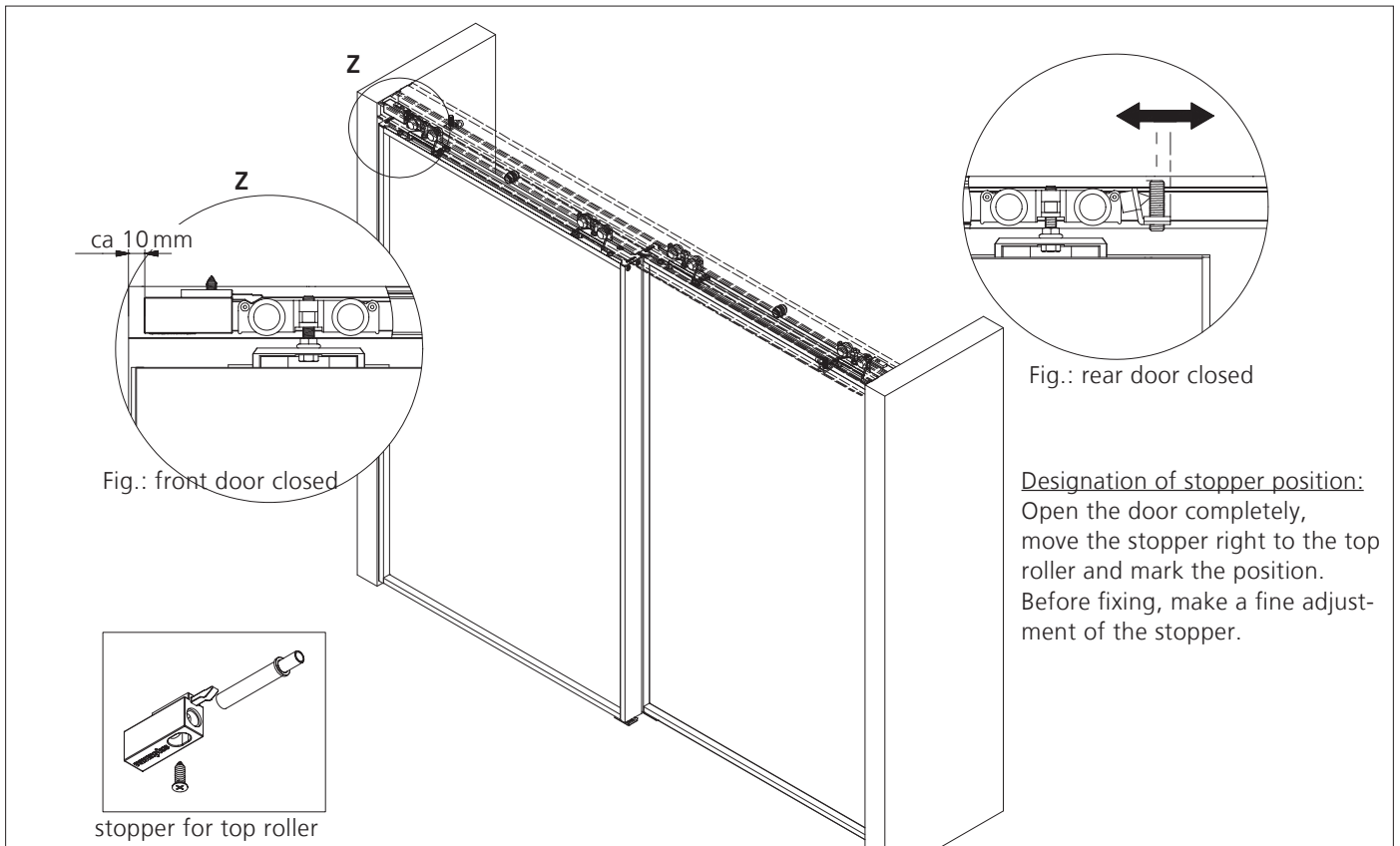

1_ Mount stopper for top roller with door brake AIR in both top track inserts at closing positions

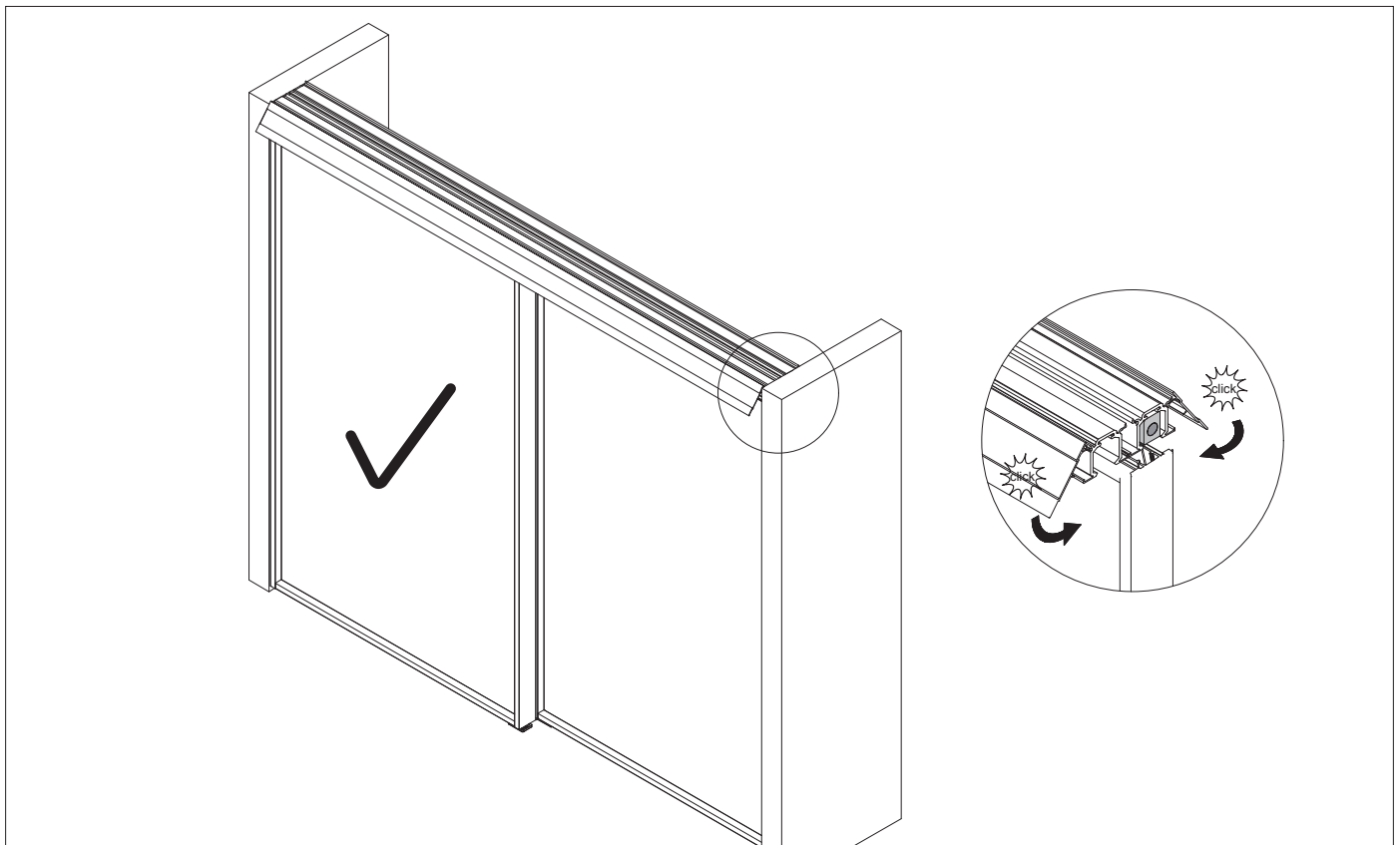

2_ Apply covers for top track insert on front and back

INSTALLATION INSTRUCTION

ACCESSOIRES TOP TRACK WALL MOUNTED

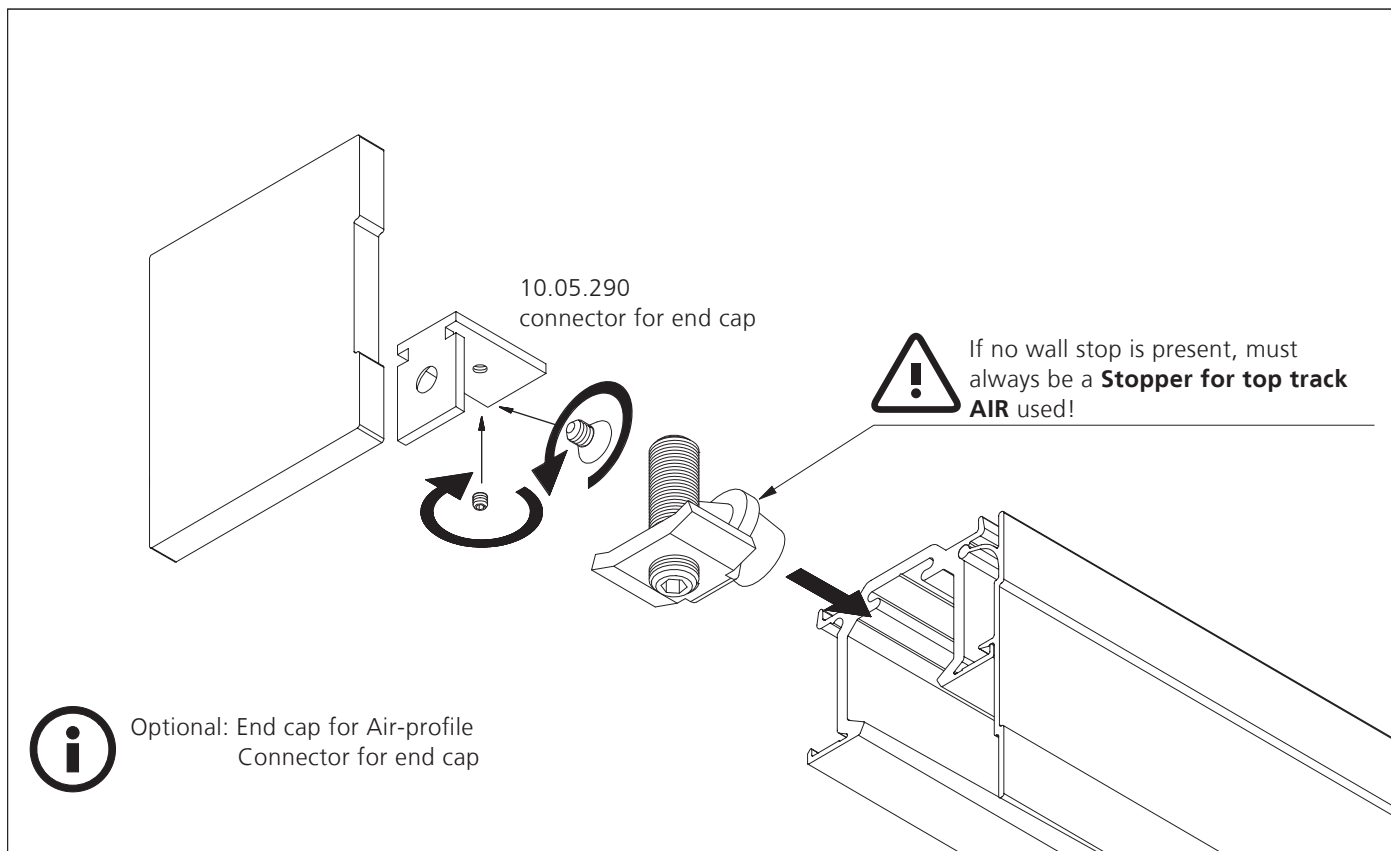

1_ End cap for wall connection profile, left / stopper for top track AIR

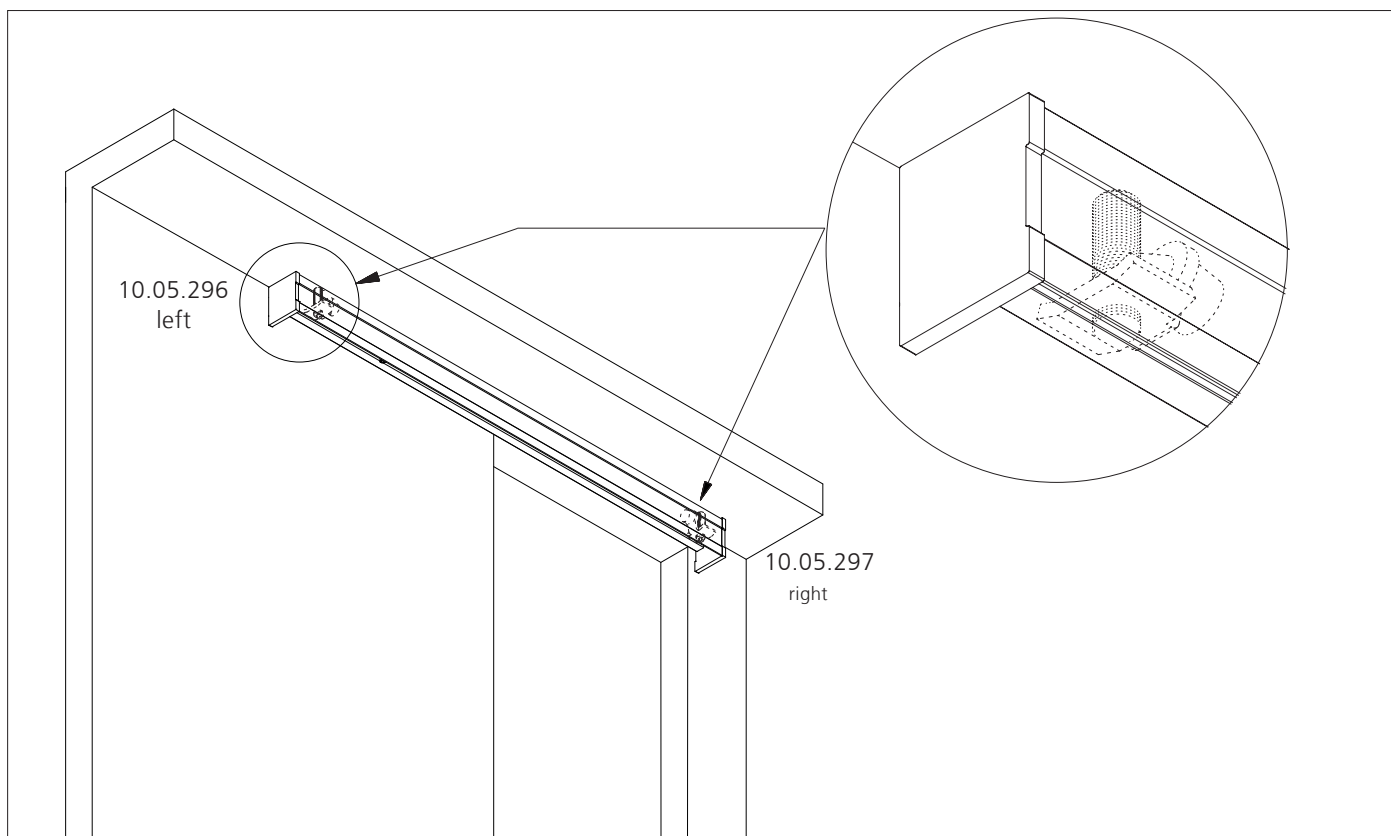

7_ End cap / stopper for top track AIR

DETAIL DRAWING

CEILING FASTENING AIR-B

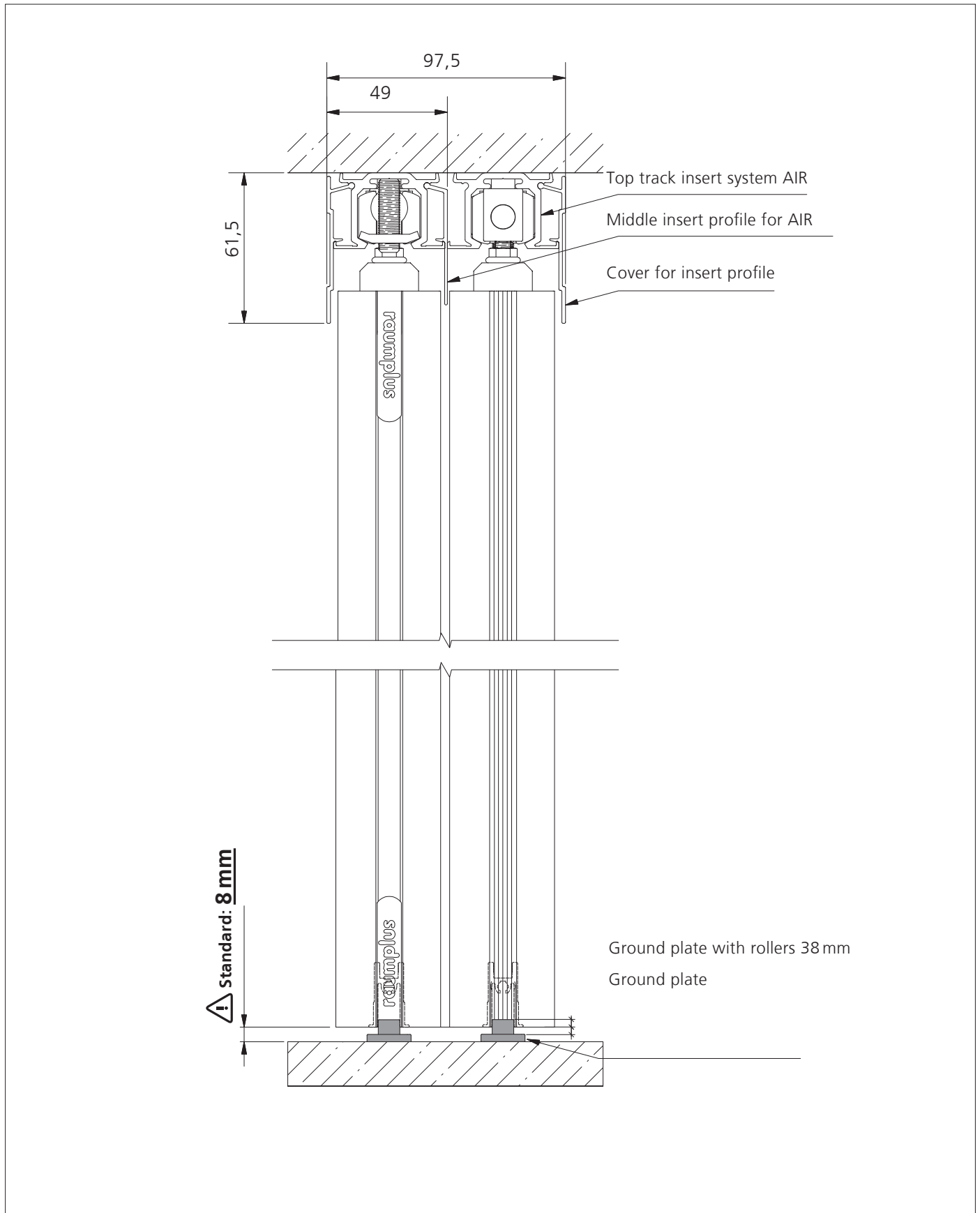

DETAIL DRAWING

WALL FASTENING AIR-B

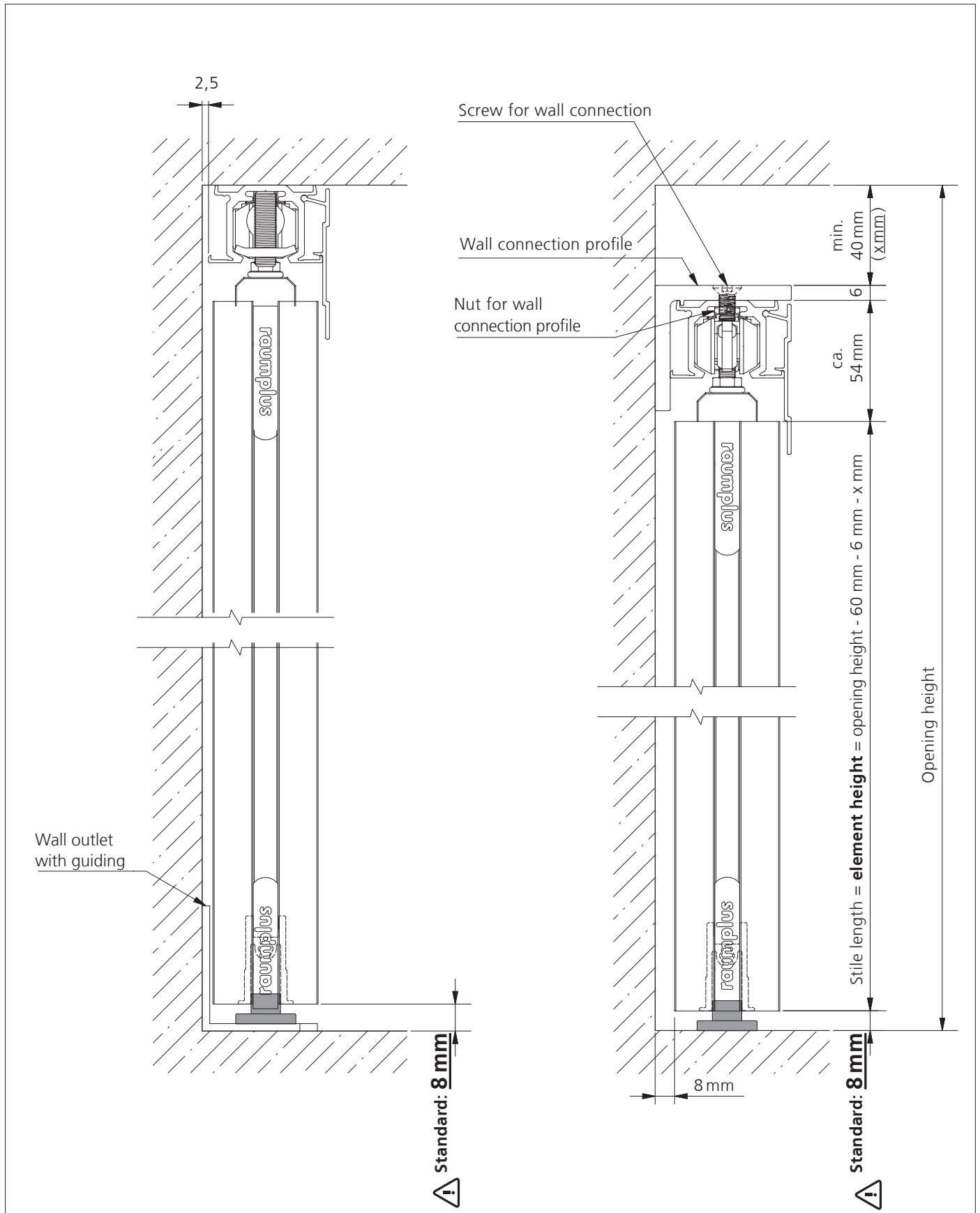

2_