

HINGE DOOR: PLANNING

ALUMINUM FRAME HINGE DOOR RPS

Version 1.2 (2017-03-30)

2.30.4.c



Subject to technical changes.

raumplus

CONTENT AND TOOLS

CONTENT:	Content	page 02
	Product information	page 03
	Accessories	page 04
	Installation variants on the corpus	page 05
	Inserted variant	page 06
	Adapter variant	page 08
	Dimensions	page 10
	Gap layout	page 11
	Magnetic push p2o	page 12
	Dimension sheet frame profile 22,5 mm, RPS	page 14
	Dimension sheet frame profile 29 mm, RPS	page 15



VERSION INFORMATION:







Version 1.1: Note to RPS 22.5, for the use of colored glass
Version 1.2: Dimension sheet added

PRODUCT INFORMATION

GENERAL INFORMATION: Preparation

- This manual is part of the product and describes the safe and proper installation of the system. Please read the instructions carefully before installation
- Please note that the assembly should only be done by qualified and trained staff in strict compliance with all details indicated in this document. Improper installation in variation from manufacturer's specification may cause defects and danger, thus endangering the safe fixing of the product as well as the safety of the prospective user. The liability of the manufacturer shall be excluded in case of defects and consequential damages resulting from incorrect assembly of this product.
- Please check the completeness of the delivered parts and check carefully if any transport damages are visible.
- If any parts are damaged or lost, please immediately contact the responsible supplier.
- It is assumed that you have exactly identified all cutting dimensions according to the measurement instruction for **raumplus** products.

SYMBOLE:

Symbol	Importance
	Risk or danger!
	Advice and information
	Additional information / other documents
	Directional data / direction of movement
	„yes“ and „right“
	„no“ and „wrong“
	Follow the order

SYSTEM:

System Information: RPS

- max. weight of element = **20 kg**
- min./max. door height = **300 mm / 2500 mm**
- min./max. door width = **300 mm / 620 mm**

ACCESSORIES

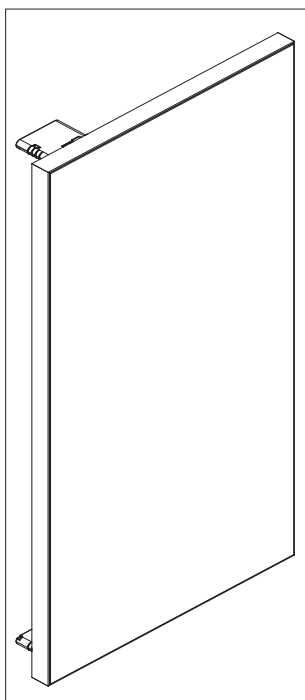

1_

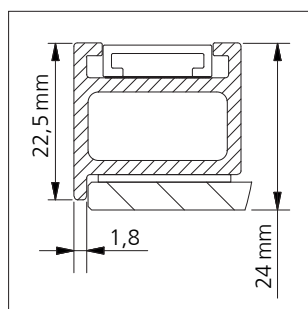

2_ 52.11.0xx

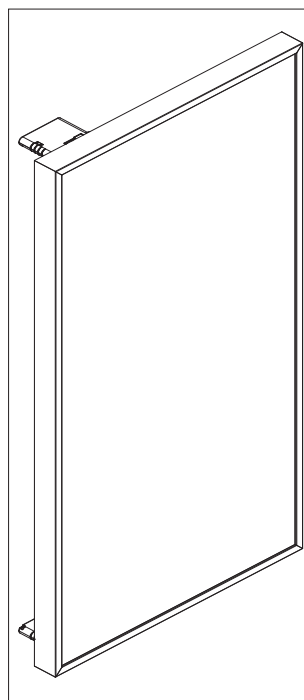

3_

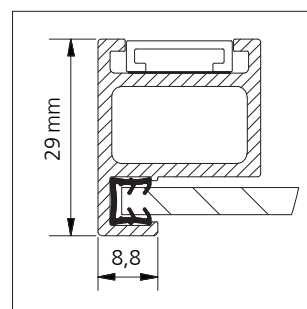

4_ 52.01.0xx

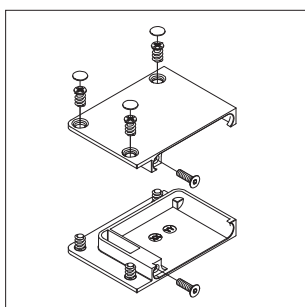

5_ 10.52.01x

1_ RPS door, Frame profile **22,5** mm

2_ Frame profile **22,5** mm, RPS

silver 52.11.020
dark bronze 52.11.050

3_ RPS door, Frame profile **29** mm

4_ Frame profile **29** mm, RPS

silver 52.01.020
dark bronze 52.01.050

5_ Adapter plate set RPS

silver lacquered 10.52.015
dark bronze lacquered 10.52.016

VARIANTS

INSTALLATION VARIANTS ON THE CORPUS EXAMPLE FRAME PROFILE **22,5 mm**

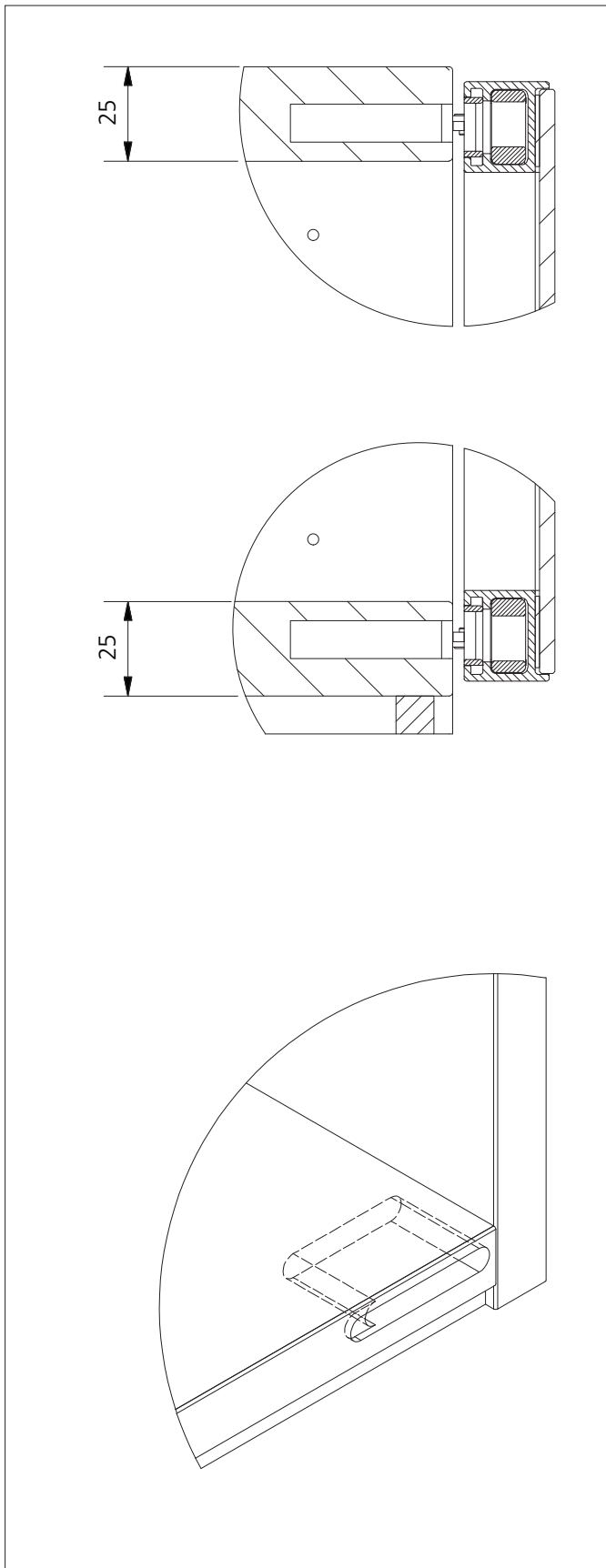

1_ Inserted variant (Pages 6 - 7)

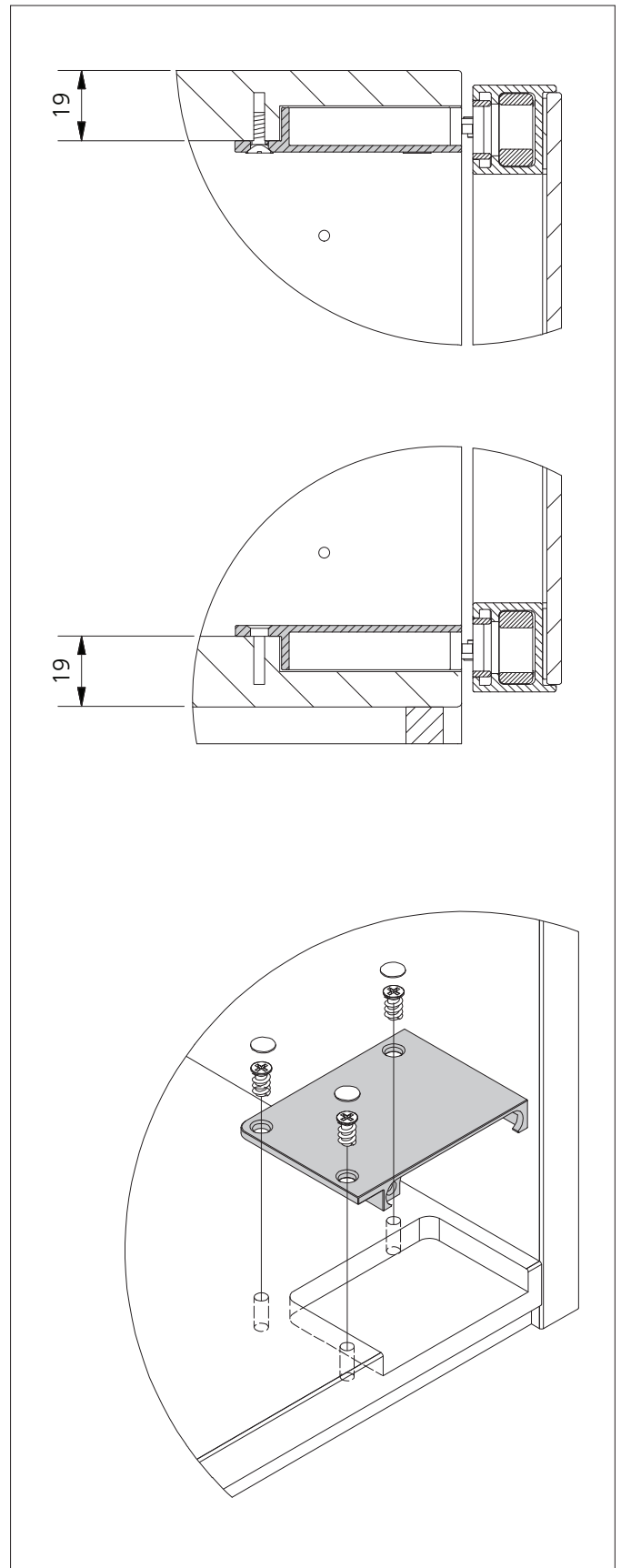

2_ Adapter variant (Pages 8 - 9)

MILLING PATTERN - SHELVES

INSERTED VARIANT

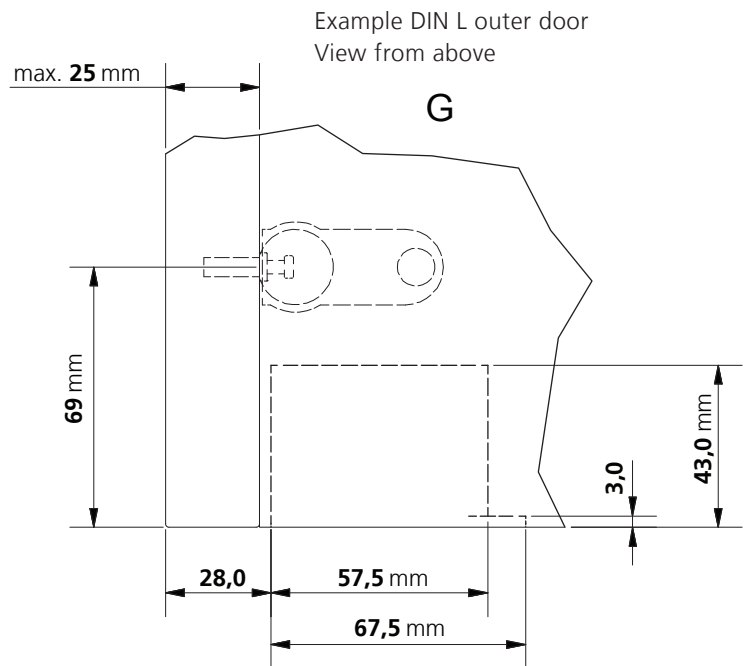
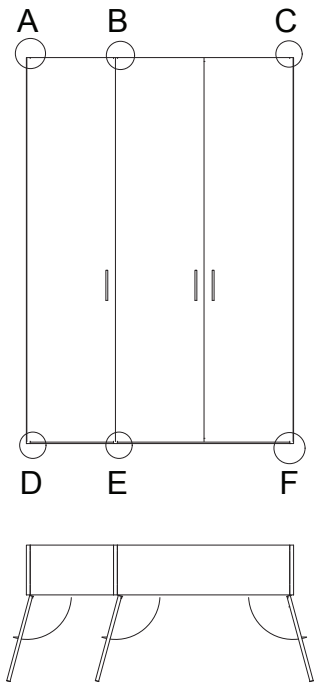

Corner stop

Half overlay

Corner stop

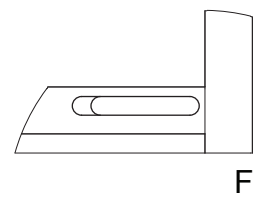
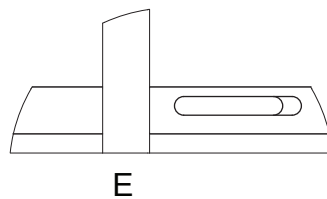
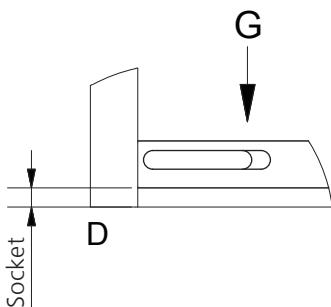
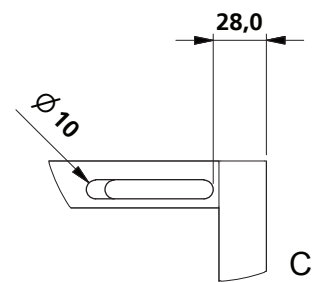
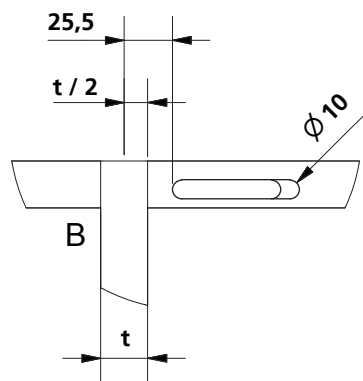
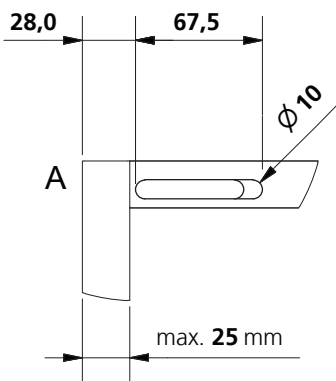

CALCULATION OF DOOR HEIGHT

VERTICAL SECTION INSERTED VARIANT

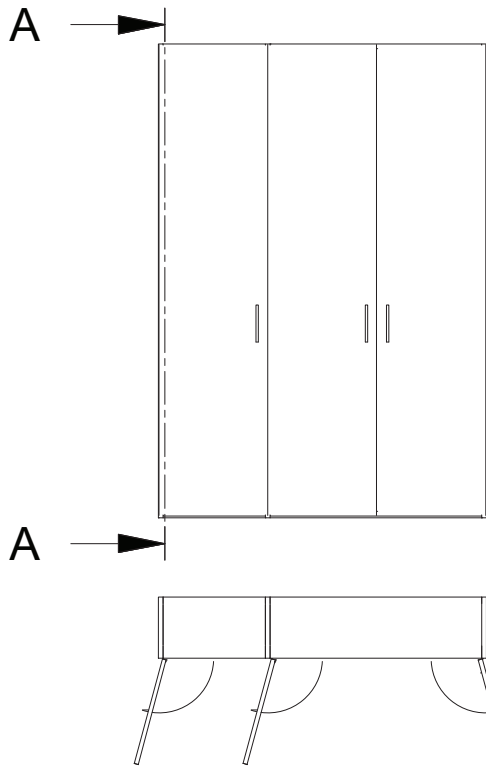

Inserted variant			
t	α	Gap	Door height
19 mm	6,5 mm	0 mm	CH = DH
22 mm	9,5 mm	3,0 mm	CH - 6 mm
25 mm	10,0 mm	3,5 mm	CH - 7 mm
28 mm	10,0 mm	3,5 mm	CH - 7 mm
32 mm	10,0 mm	3,5 mm	CH - 7 mm

Material thickness **t** = _____

Corpus height **CH** = _____

Door height **DH** = _____

e.g. FPY 25 mm

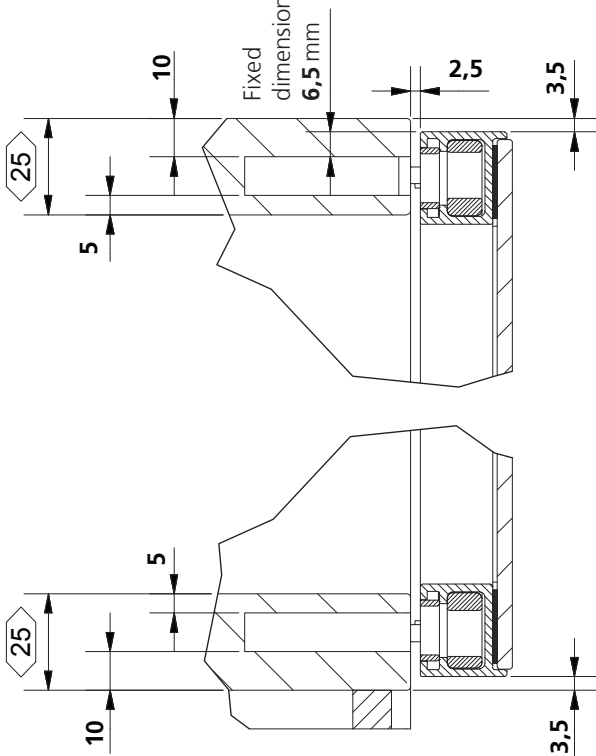

with variables

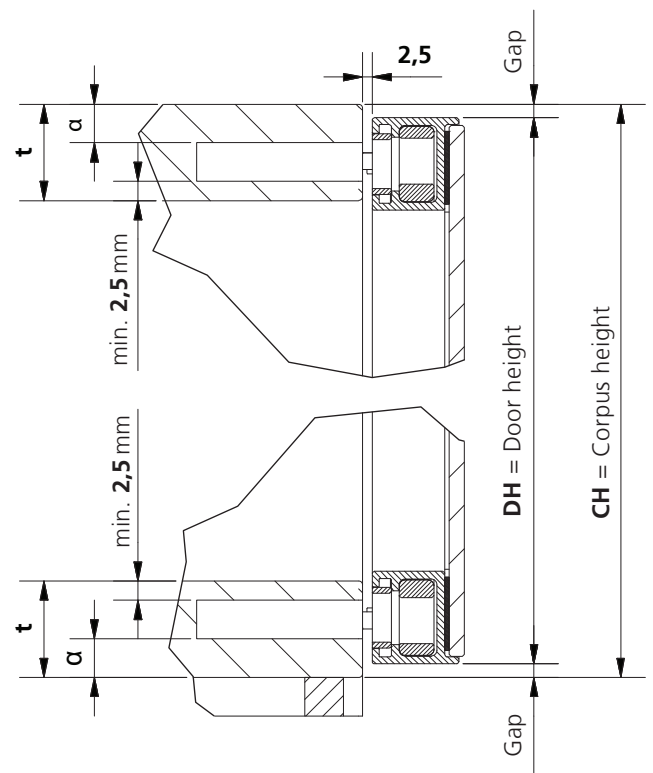

1_ Example 25 mm

MILLING PATTERN - SHELVES

ADAPTER VARIANT

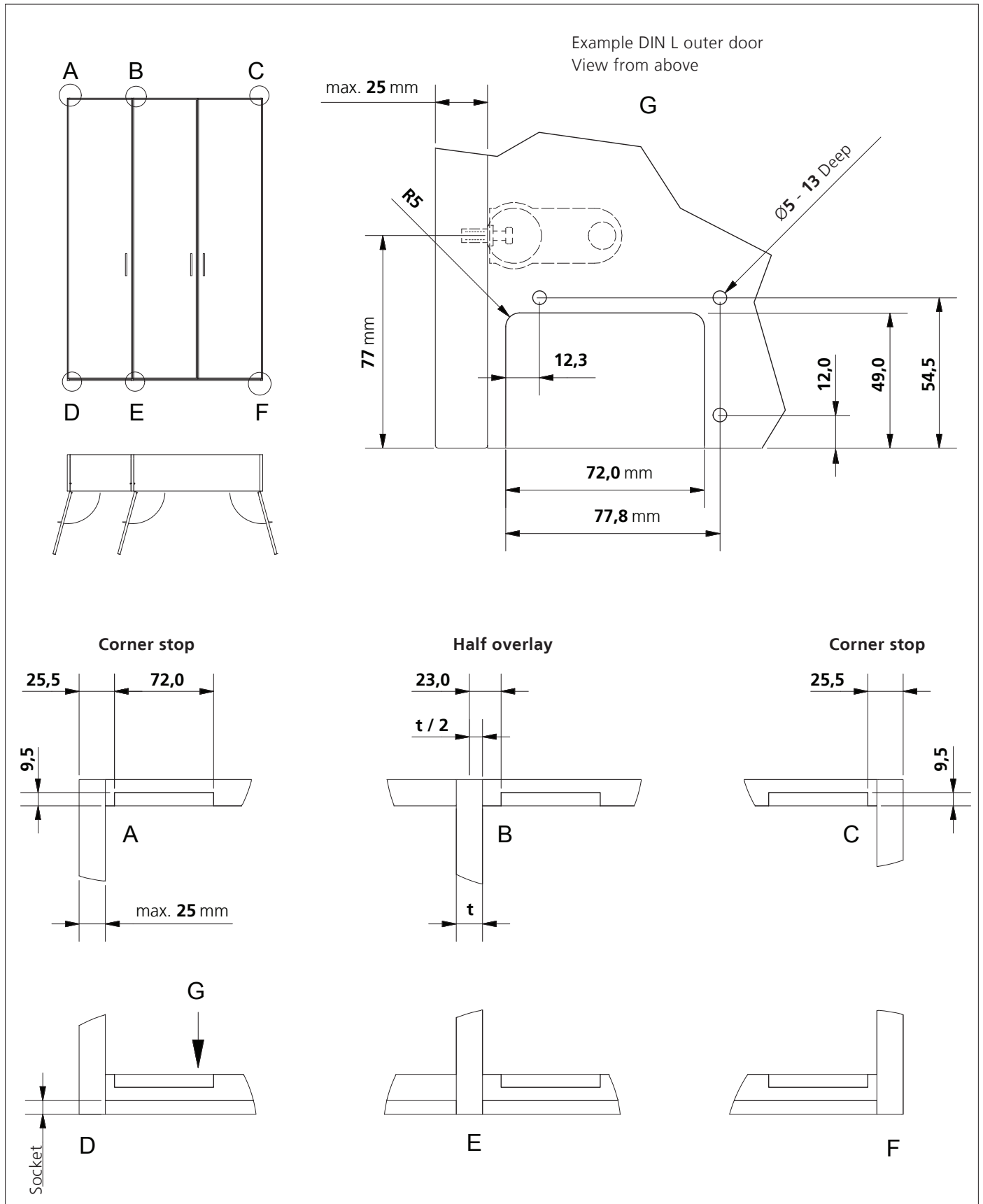

CALCULATION OF DOOR HEIGHT

VERTICAL SECTION ADAPTER VARIANT



No drawers can be installed in the area of the adapter plates.

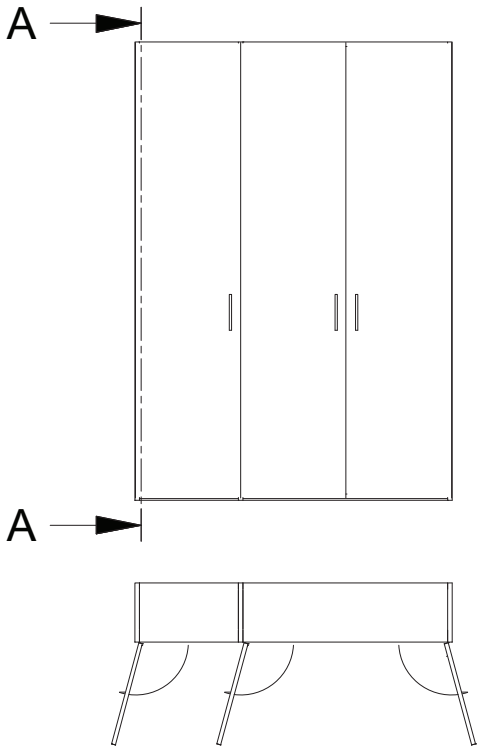

Table of variables		
t	Gap	Door height
18 mm	2,5 mm	KH - 5 mm
19 mm	3,5 mm	KH - 7 mm
22 mm	6,5 mm	KH - 13 mm
25 mm	9,5 mm	KH - 19 mm
28 mm	12,5 mm	KH - 25 mm
32 mm	16,5 mm	KH - 33 mm

Material thickness **t** = _____

Corpus height **CH** = _____

Door height **DH** = _____

e.g. FPY 19 mm

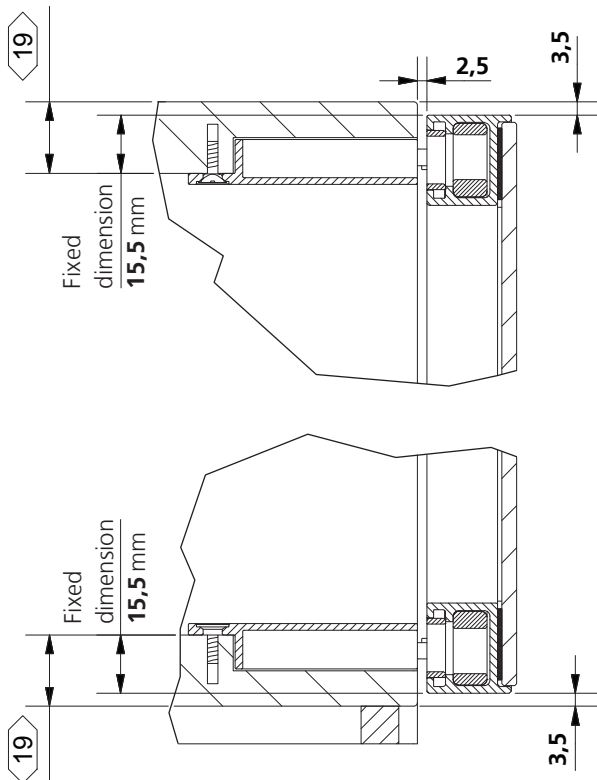

with variables

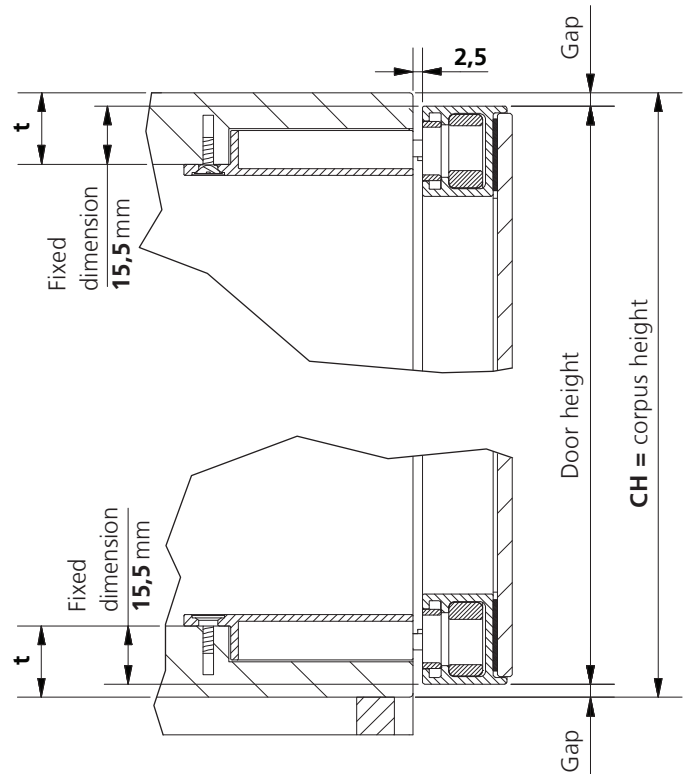

1_ Example 19 mm

DETAIL DRAWING

DIMENSIONS CORPUS

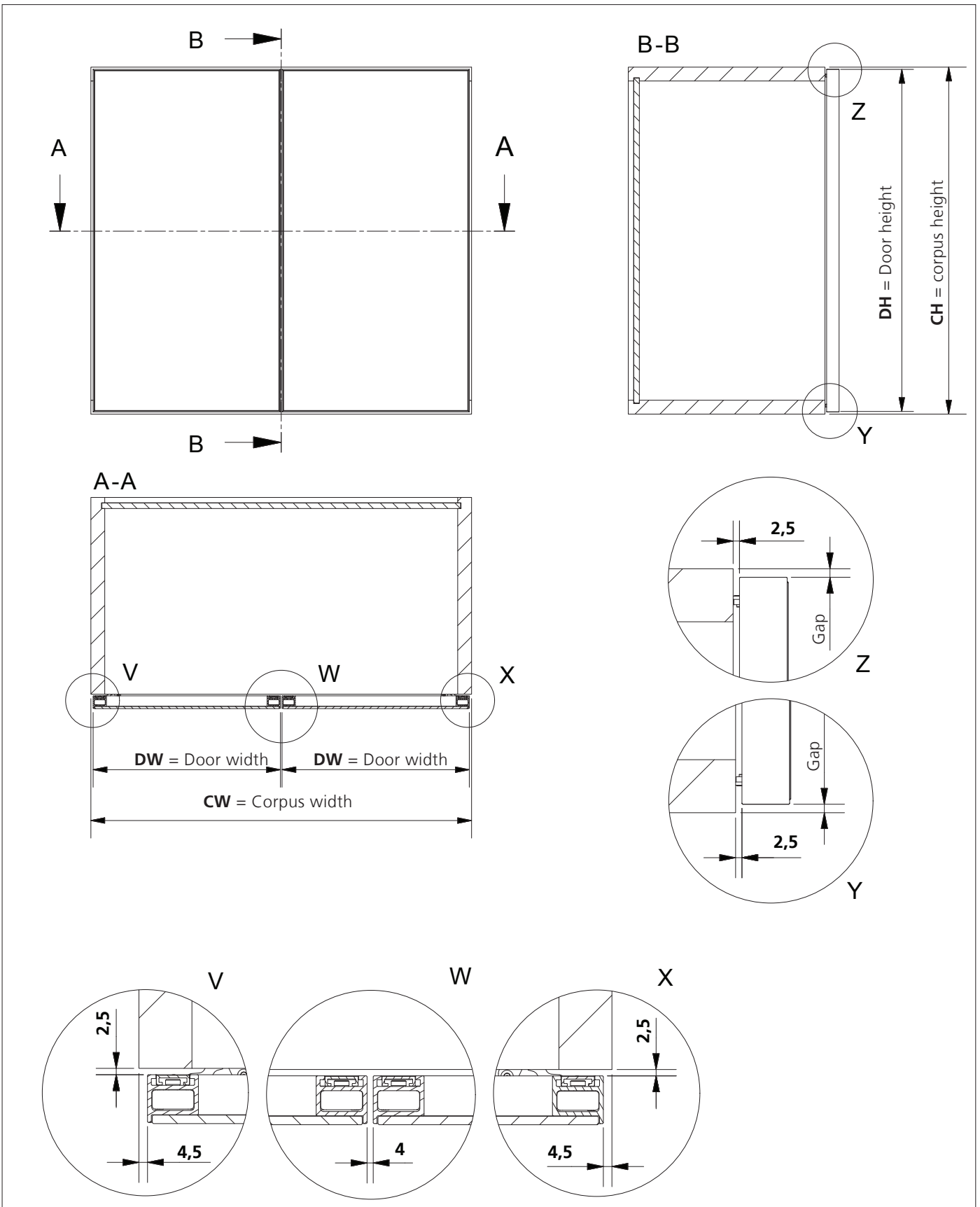

CALCULATION OF DOOR WIDTH

GAP LAYOUT

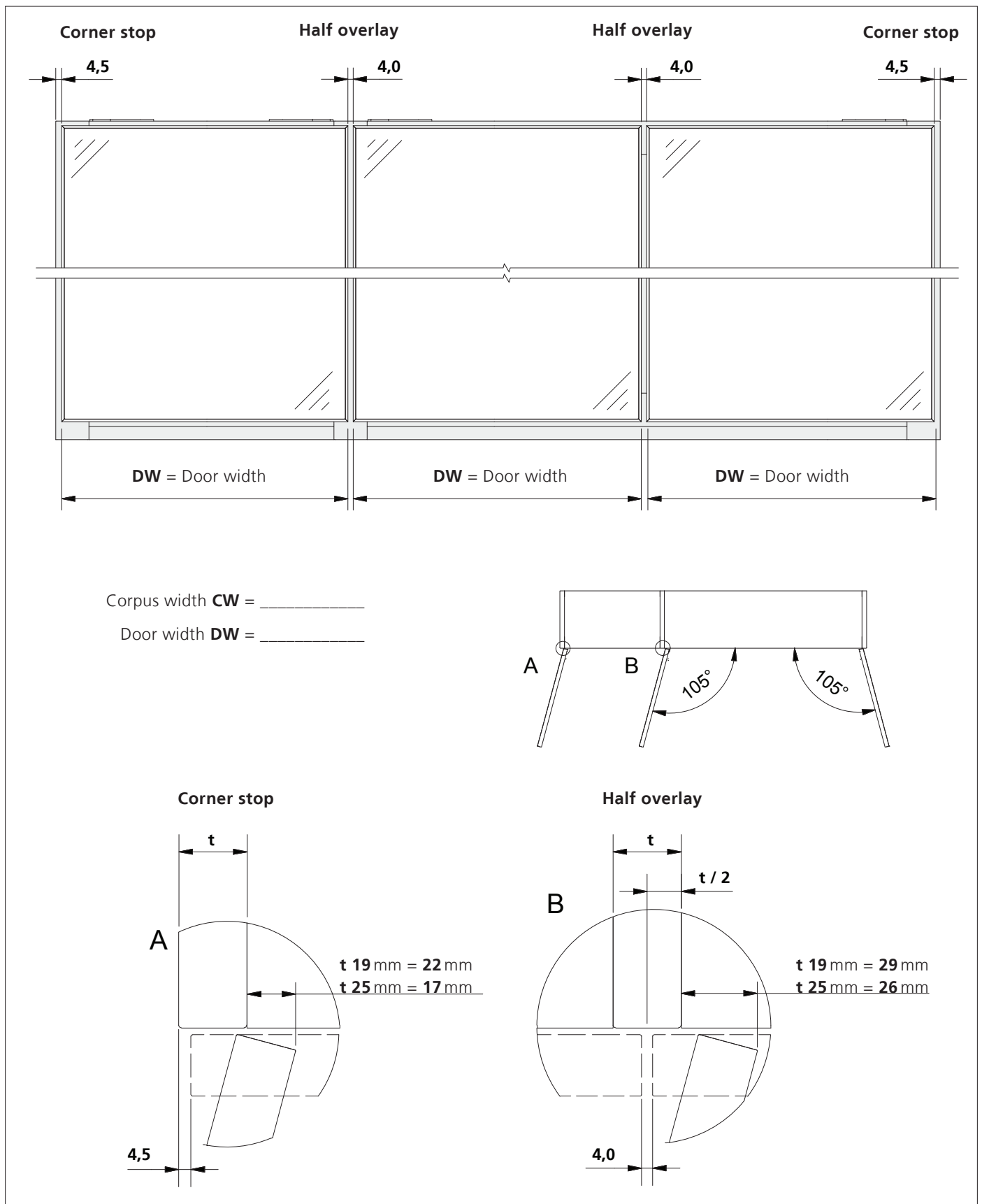

DETAIL DRAWING

MAGNETIC PUSH P2O (PUSH TO OPEN)

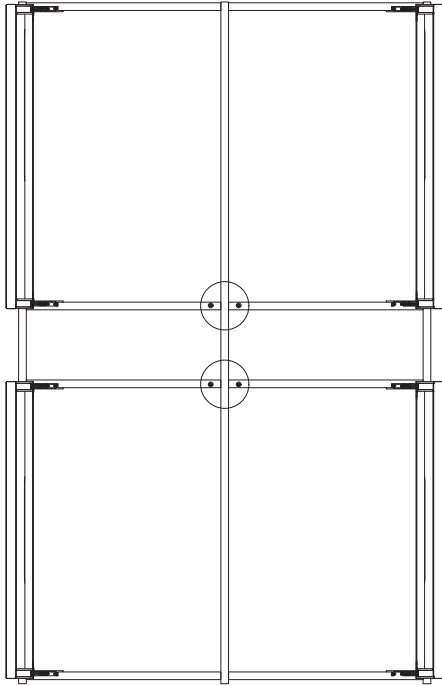

For magnetic push p2o: for the door hinge p2o (push to open), a construction shelf must be planned. The front edge of the shelf must be flush with the sides.



In the area of the magnetic push p2o (push to open for the door hinge p2o), no shelf support should be used.

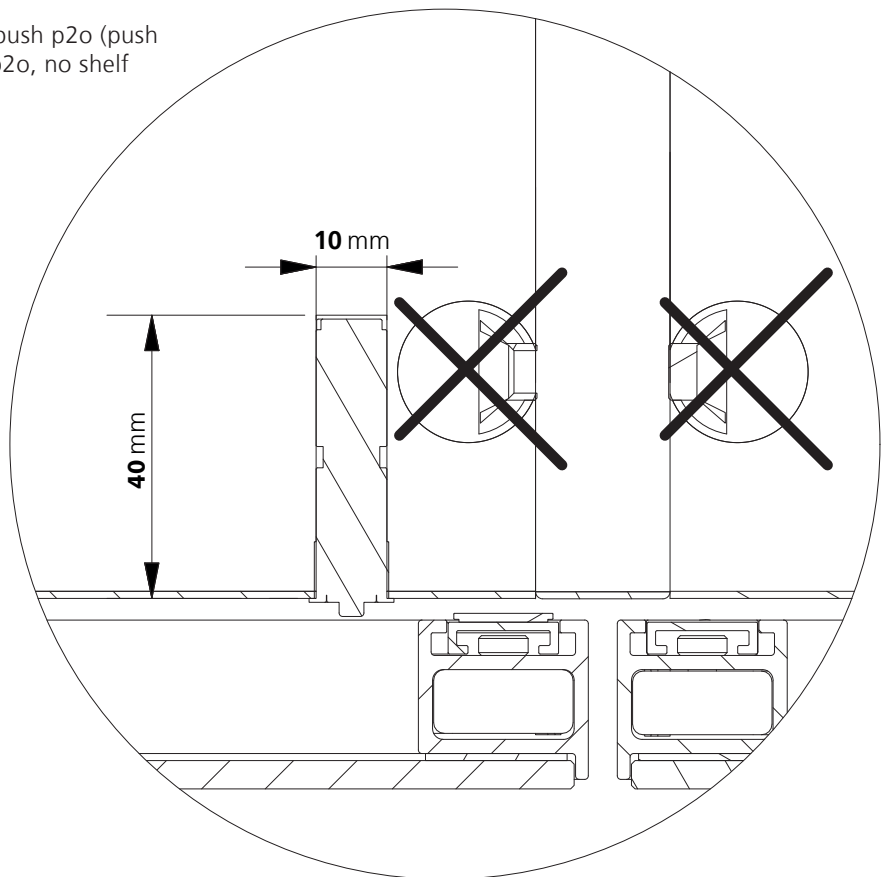

1_ Changes to the shelves with RPS hinge doors

DETAIL DRAWING

MAGNETIC PUSH P2O (PUSH TO OPEN)

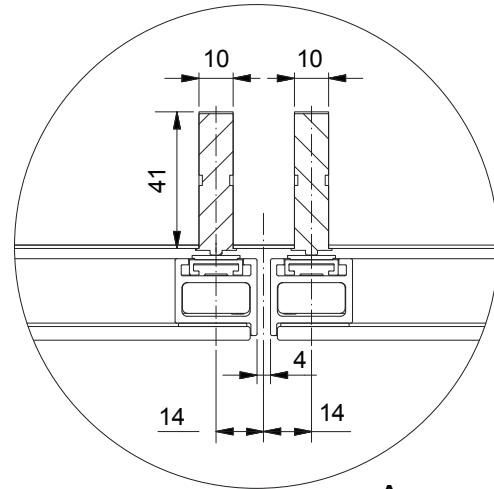
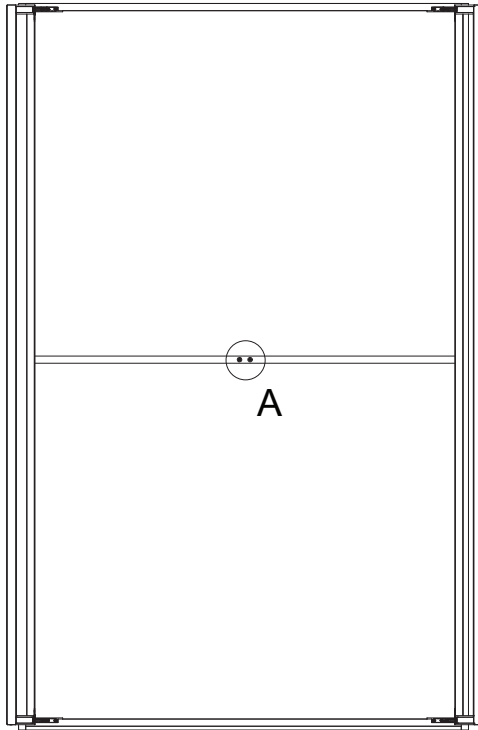

A

Push to open hinges are only intended for cabinets with semi-high doors.

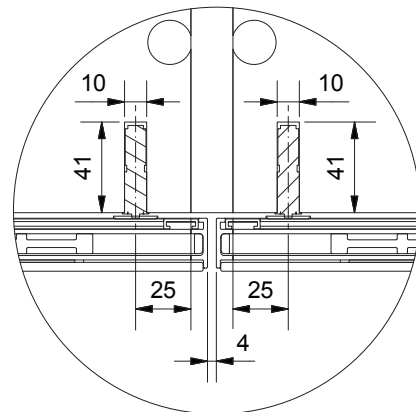
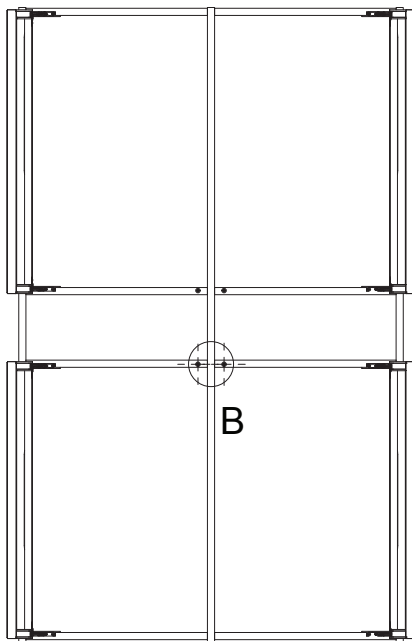
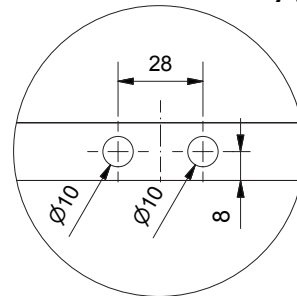

B

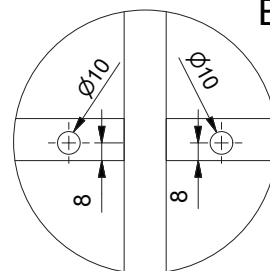

Customer:	
Commission:	
Order processing No.:	

Frame profile **22,5 mm**, RPS

RPS information

	min.	max.
Door weight	/	je: 20 kg
Door height	300 mm	2500 mm
Door width	300 mm	620 mm

Frame profile **22,5 mm**, RPS

PS = (DW - 4 mm) x (DH - 4 mm)

Panel tolerance: +0,0 ; -1,0 mm

Glass thickness: 4,00 mm

All edges sanded and polished chamfer 1mm x 45°

DW = Door weight

DH = Door height

R = Rail

S = Stilel

CP = Cover profile

PS = Panel size

i Only colored glass with PE safety backing.

Door with left-hand hinge

Door with right-hand hinge

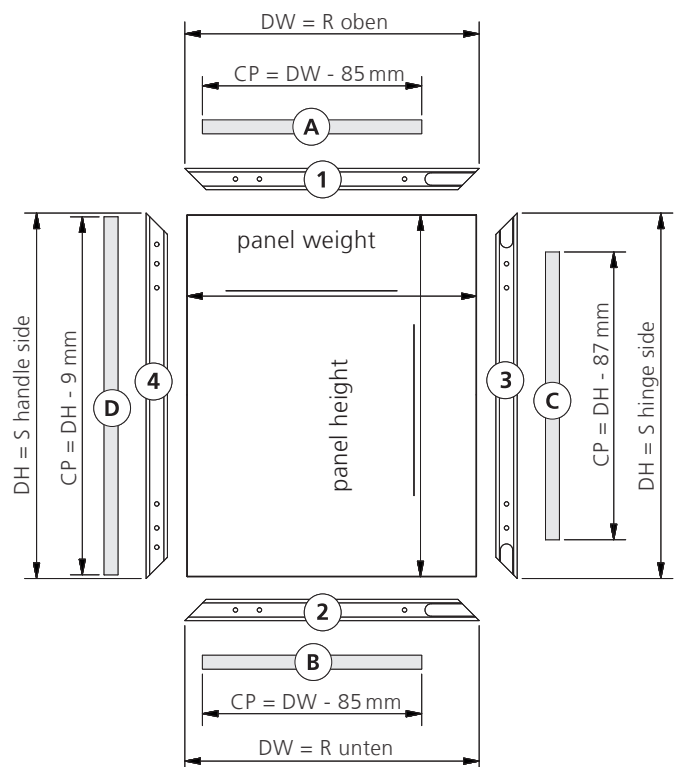
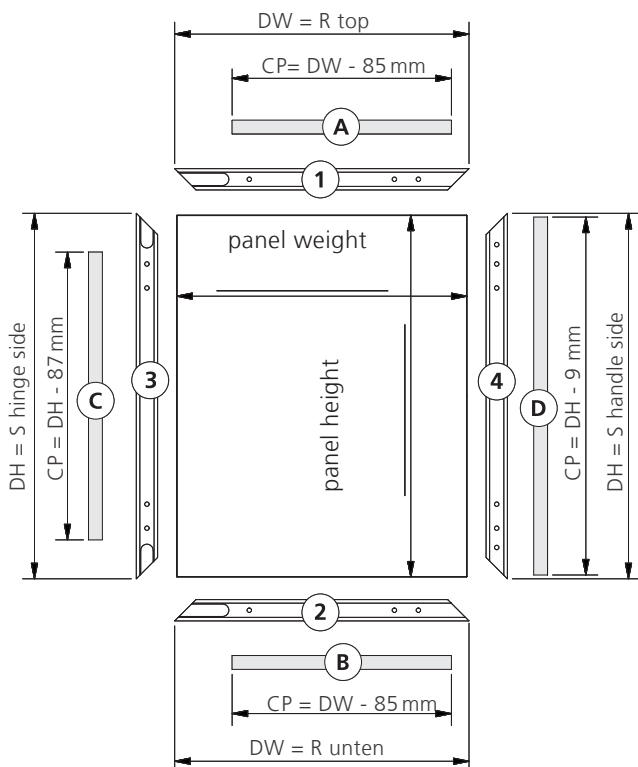
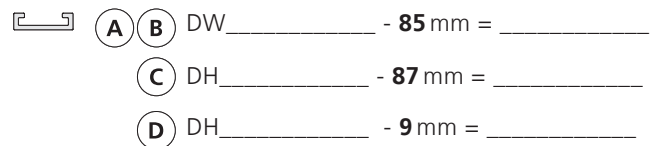
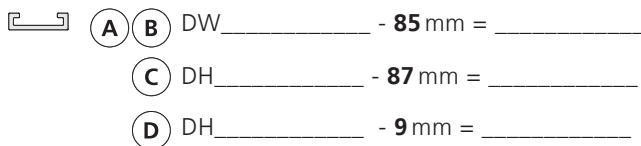
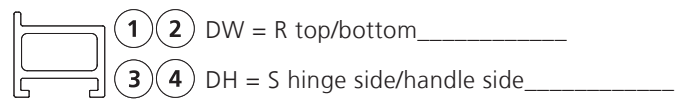
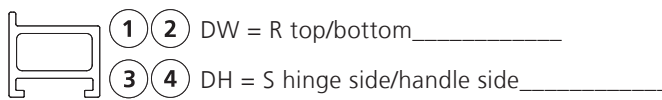

Processor: _____

Name, Date

Customer:	
Commission:	
Order processing No.:	

Frame profile **29 mm**, RPS

RPS information

	min.	max.
Door weight	/	je: 20 kg
Door height	300 mm	2500 mm
Door width	300 mm	620 mm

Frame profile **29 mm**, RPS
 PS= (DW - 7 mm) x (DH - 7 mm)
 Glass thickness: 4,00 mm
 All edges sanded

DW = Door weight
 DH = Door height
 R = Rail
 S = Stiel
 CP = Cover profile
 PS = Panel size

Door with left-hand hinge

Door with right-hand hinge

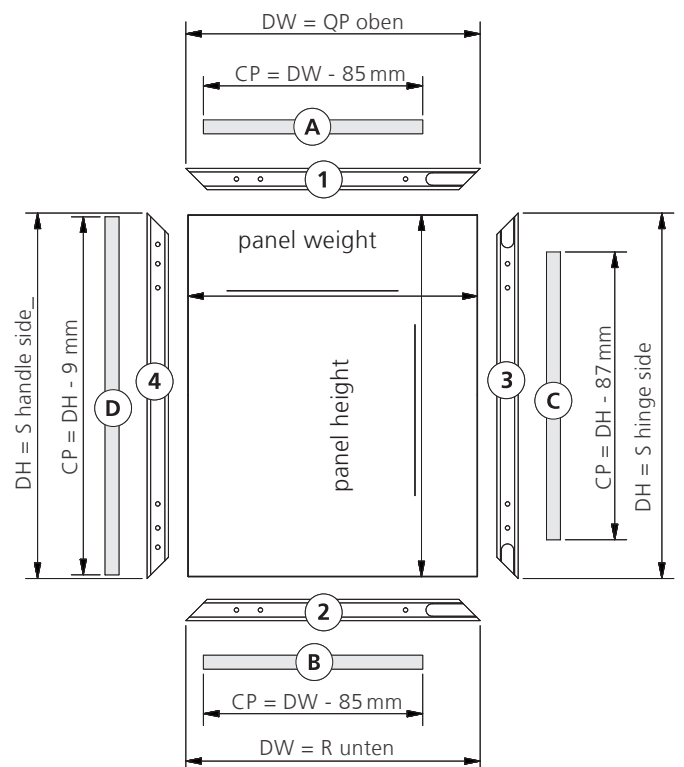
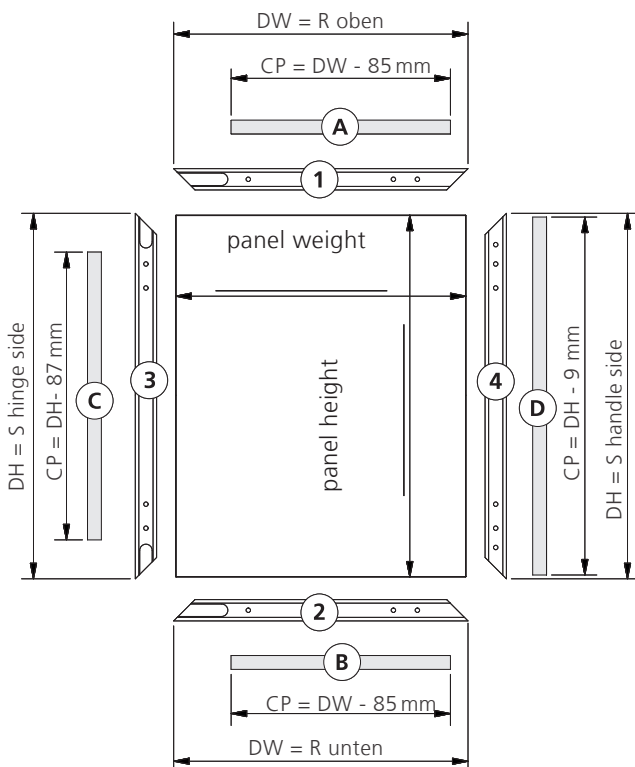
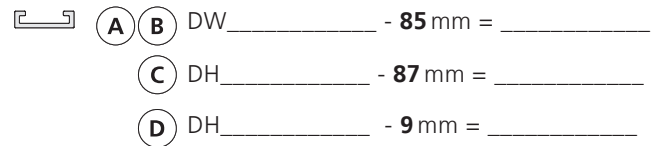
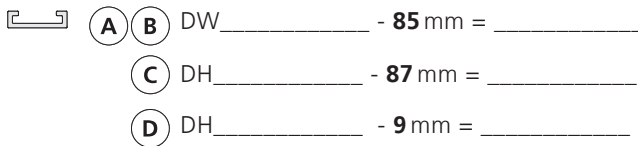
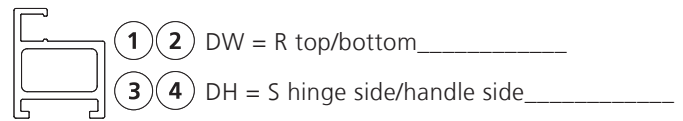
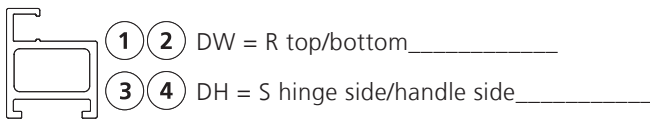

Processor: _____
 Name, Date